

MOUNTING AND OPERATING INSTRUCTIONS

EB 8325 EN

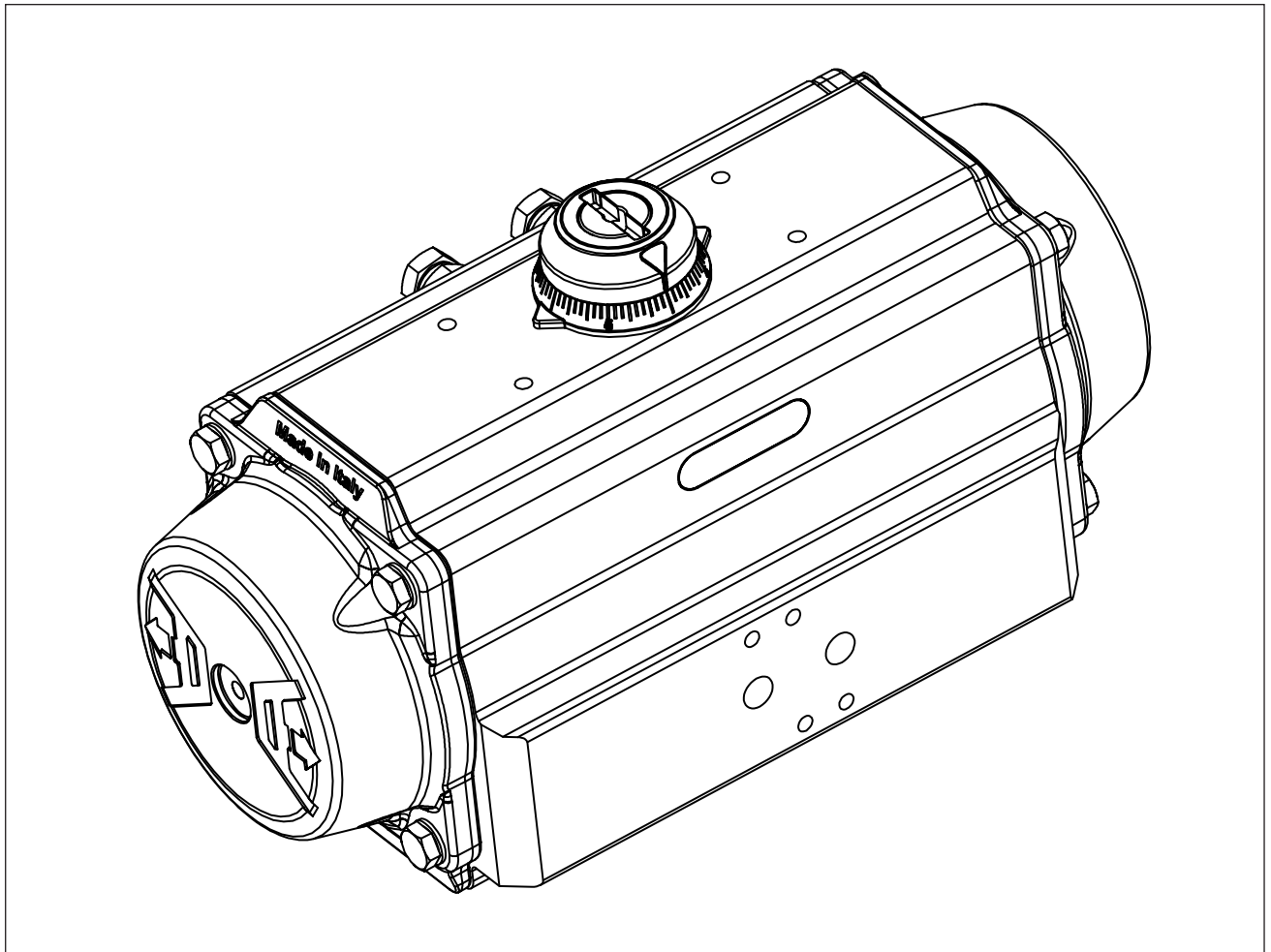

Original instructions



SAMSON ROTACTOR® RP 3171

Pneumatic rack and pinion actuators
AT045U → AT801U models

Edition May 2022



Note on these mounting and operating instructions

These mounting and operating instructions assist you in mounting and operating the device safely. The instructions are binding for handling SAMSON devices. The images shown in these instructions are for illustration purposes only. The actual product may vary.

- For the safe and proper use of these instructions, read them carefully and keep them for later reference.
- If you have any questions about these instructions, contact SAMSON's After-sales Service Department (samson@samsongroup.com).



The mounting and operating instructions for the devices are included in the scope of delivery. The latest documentation is available on our website at www.samsongroup.com > **Service & Support** > **Downloads** > **Documentation**.

Definition of signal words

DANGER

Hazardous situations which, if not avoided, will result in death or serious injury

WARNING

Hazardous situations which, if not avoided, could result in death or serious injury

NOTICE

Property damage message or malfunction

Note

Additional information

Tip

Recommended action

1	Safety instructions and measures	1-1
1.1	Notes on possible severe personal injury	1-2
1.2	Notes on possible personal injury	1-2
1.3	Notes on possible property damage	1-2
2	Markings on the device	2-1
2.1	Actuator nameplate sample	2-1
3	Design and principle of operation	3-1
3.1	Direction of action and fail position	3-1
3.2	Complementary/accessory parts	3-2
3.3	Technical data	3-2
4	Shipment and on-site transport	4-1
4.1	Accepting the delivered goods	4-1
4.2	Removing the packaging from the actuator	4-1
4.3	Transporting and lifting the actuator	4-1
4.3.1	Transporting the actuator	4-1
4.3.2	Lifting the actuator	4-1
4.4	Storing the actuator	4-2
5	Mounting and assembly	5-1
5.1	Preparation for installation	5-1
5.2	Control and signal devices assembly	5-1
5.3	Mounting the actuator over the valve	5-1
6	Start-up	6-1
7	Operation	7-1
8	Malfunctions	8-1
8.1	Troubleshooting	8-1
8.2	Emergency action	8-1
9	Service	9-1
9.1	Preparation for servicing	9-1
9.2	Part list	9-2
9.3	Disassembly	9-4
9.4	Service operations	9-6
9.5	Reassembly	9-6
10	Decommissioning	10-1
11	Removal	11-1
12	Repairs	12-1
13	Disposal	13-1
14	Certificates	14-1
15	Annex	15-1
15.1	Tools	15-1
15.2	Tightening torque	15-3
15.3	Lubricants	15-4
16	Rubber products storage instructions	16-1
16.1	Overview	16-1
16.2	Storage conditions	16-1
16.3	Storage life	16-2

1 Safety instructions and measures

Intended use

The SAMSON ROTACTOR RP 3171 actuators are designed for the automation and operation of quarter-turn valves such as butterfly valves, ball valves and plug valves in both indoor and outdoor applications. Depending on the configuration, the actuator is suitable for on/off or modulating duties. The actuator can be used in process and industrial plants.

The actuator is designed to operate under exactly defined conditions (e.g. temperature, pressure, travel). Therefore, operators must ensure that the actuator is only used in operating conditions that meet the specifications used for sizing the actuator at the ordering stage. In case operators intend to use the actuator in other applications or conditions than specified, contact SAMSON.

SAMSON does not assume any liability for damage resulting from the failure to use the device for its intended purpose or for damage caused by external forces or any other external factors.

- ➔ Refer to the technical data and nameplate for limits and fields of application as well as possible uses.

Reasonably foreseeable misuse

The actuator is not suitable for the following applications:

- Use outside the limits defined during sizing and by the technical data.
- Use outside the limits defined by the accessories connected to the actuator.

Furthermore, the following activities do not comply with the intended use:

- Use of non-original spare parts.
- Performing service and repair work not described in these instructions.

Qualifications of operating personnel

The actuator must be mounted, started up, serviced and repaired by fully trained and qualified personnel only; the accepted industry codes and practices are to be observed. According to these mounting and operating instructions, trained personnel refers to individuals who are able to judge the work they are assigned to and recognize possible hazards due to their specialized training, their knowledge and experience as well as their knowledge of the applicable standards.

Personal protective equipment

We recommend wearing the following personal protective equipment when handling the SAMSON actuators:

- Protective gloves and safety footwear when mounting or removing the actuator.
- Eye protection and hearing protection while the actuator is operating.
- ➔ Check with the plant operator for details on further protective equipment.

Revisions and other modifications

Revisions, conversions or other modifications of the product are not authorized by SAMSON. They are performed at the user's own risk and may lead to safety hazards, for example. Furthermore, the product may no longer meet the requirements for its intended use.

Safety devices

The SAMSON pneumatic actuators alone do not have any special safety equipment.

Warning against residual hazards

To avoid personal injury or property damage, plant operators and operating personnel must prevent hazards that could be caused in the actuator by the signal pressure, stored spring energy or moving parts by taking appropriate precautions. They must observe all hazard statements, warning and caution notes in these mounting and operating instructions.

Responsibilities of the operator

The operator is responsible for proper operation and compliance with the safety regulations. Operators are obliged to provide these mounting and operating instructions as well as the referenced documents to the operating personnel and to instruct them in proper operation.

Furthermore, the operator must ensure that operating personnel or third persons are not exposed to any danger.

These instructions should not supersede or replace any customer's plant safety or work procedures. If a conflict arises between these instructions and the customer's procedures, the differences should be resolved in writing between an authorized end user's representative and an authorized SAMSON representative.

Responsibilities of operating personnel

Operating personnel must read and understand these mounting and operating instructions as well as the referenced documents and observe the specified hazard statements, warnings and caution notes. Furthermore, the operating personnel must be familiar with the applicable health, safety and accident prevention regulations and comply with them.

Referenced standards and regulations

- SAMSON actuators are designed, produced and classified according to the European Atex directive 2014/34/EU and U.K. Regulation S.I. 2016 No. 1107 (as amended). Before using the actuators in potentially explosive atmosphere areas, verify the actuator compliance with the required ATEX and UKCA classification.
- ➔ Refer to the nameplate and the ATEX / UKCA safety instructions.
- SAMSON ROTACTOR RP 3171 actuators are SIL certified.
- ➔ Refer to the SIL Certificate available from SAMSON for the SAMSON ROTACTOR RP 3171 actuators SIL capability.
- Referring to Machine Directive 2006/42/EC and U.K. Regulation

Safety instructions and measures

- S.I. 2008 No. 1597 (as amended), actuators are classified as “partly machinery” (see Declaration of incorporation).
Therefore, the actuator cannot to be put into service until the machinery and/or the final system, where the actuator is incorporated, will be declared in compliance with the requirements of the Directive.
- The SAMSON pneumatic actuators are designed according to the criteria of
- Article 1, paragraph 2. j) ii) of the Pressure equipment directive (PED) 2014/68/EU.
- Part 1, section 4, schedule 1, paragraph 1. j) ii) of U.K. Regulation S.I. 2016 No. 1105 (as amended).
- Therefore, according to the directive 2014/68/EU and
- U.K. Regulation S.I. 2016 No. 1105 (as amended) they are not to be considered pressure equipments.
- ➔ Refer to the EU Declaration of Conformity available from SAMSON.
- The SAMSON actuators are in compliance with the TR CU 10/2011 and TR CU 12/2011.

Referenced documentation

The further documents apply in addition to these mounting and operating instructions:

- Mounting and operating instructions for the valve, available from the valve manufacturer,
- Mounting and operating instructions for control and signal devices (positioner, solenoid valve, etc.) available from devices manufacturer,
- ATEX safety manual,
- SIL safety manual for use in safety-instrumented systems.

1.1 Notes on possible severe personal injury

DANGER

Risk of bursting due to incorrect opening of pressurized equipment or components.

Pneumatic actuators are pressure equipment that may burst when handled incorrectly. Flying projectile fragments or components can cause serious injury or even death.

- ➔ Before starting any work on the actuator disconnect all pneumatic / hydraulic / electrical supplies and discharge the pressure from the actuator.

Risk of severe personal injury due to suspended loads falling.

- ➔ Stay far from suspended or moving loads.
- ➔ Close off and secure the transport paths.

1.2 Notes on possible personal injury

WARNING

Risk of lifting equipment tipping over and risk of damage to lifting accessories due to exceeding the rated lifting capacity.

- ➔ Use only approved lifting equipment and accessories whose maximum lifting capacity is higher than the actuator weight (including the packaging, if applicable).

Crush hazard arising from moving parts.

The actuator and the valve assembly contains moving parts, which can injure hands or fingers.

- ➔ Do not touch or insert hands or finger into moving parts.
- ➔ Before starting any work on the actuator disconnect all pneumatic / hydraulic / electrical supplies and discharge the pressure from the actuator.
- ➔ Do not block the movement of the pinion and the pistons by inserting objects into the actuator.

Risk of personal injury during actuator air exhaust.

In case of pneumatic version the actuator is operated with air. As a result, air is exhausted during operation.

- ➔ Install the air exhaust components in such a way that exhaust ports are not located at eye level and the actuator does not discharge at eye level in the working position.
- ➔ Use suitable silencers and vent plugs.
- ➔ Wear eye and hearing protection when working near the actuator.

Risk of personal injury due to preloaded and compressed springs.

End caps are under tension due to compressed springs. Furthermore incorrect spring cartridges disassembly could result in serious injury.

- ➔ Before starting any work on the actuator disconnect all pneumatic / hydraulic / electrical supplies and discharge the pressure from the actuator.
- ➔ Make sure that the actuator is in the closed position (0°) while disassembling the end caps and the stop screws have been correctly removed.
- ➔ Do not disassemble individual spring cartridges.
- ➔ For spring cartridges service contact SAMSON.

Risk of personal injury through incorrect operation, use or installation as a result of information on the actuator being illegible.

Over time, markings, labels and nameplates on the actuator may become covered with dirt or become illegible in some other way. As a result, hazards may go unnoticed and the necessary instructions not followed. There is a risk of personal injury.

- ➔ Keep all relevant markings and inscriptions on the device in a constantly legible status.
- ➔ Immediately renew damaged, missing or incorrect nameplates or labels.

1.3 Notes on possible property damage

NOTICE

Risk of actuator damage due to incorrectly attached slings.

→ Do not attach load-bearing slings to the travel stop.

Risk of actuator damage due to the use of inappropriate tools.

Certain tools are required to work on the actuator.

→ Do not use damaged tools. Refer to section 15.1 'Tools'.

Risk of actuator damage due to excessively high or low tightening torques.

Observe the specified torques on tightening actuator components (bolts and nuts). Excessive tightening torques lead to parts wearing out quicker. Parts that are not tightened enough may loosen.

→ Refer to section 15.2 'Tightening torques'.

Risk of actuator damage due to the use of unsuitable lubricants.

The lubricants to be used depend on the actuator material and operating temperatures. Unsuitable lubricants may corrode and damage the components.

→ Use only lubricants approved by SAMSON. Refer to section 15.3 'Lubricants'.

2 Markings on the device

2.1 Actuator nameplate sample

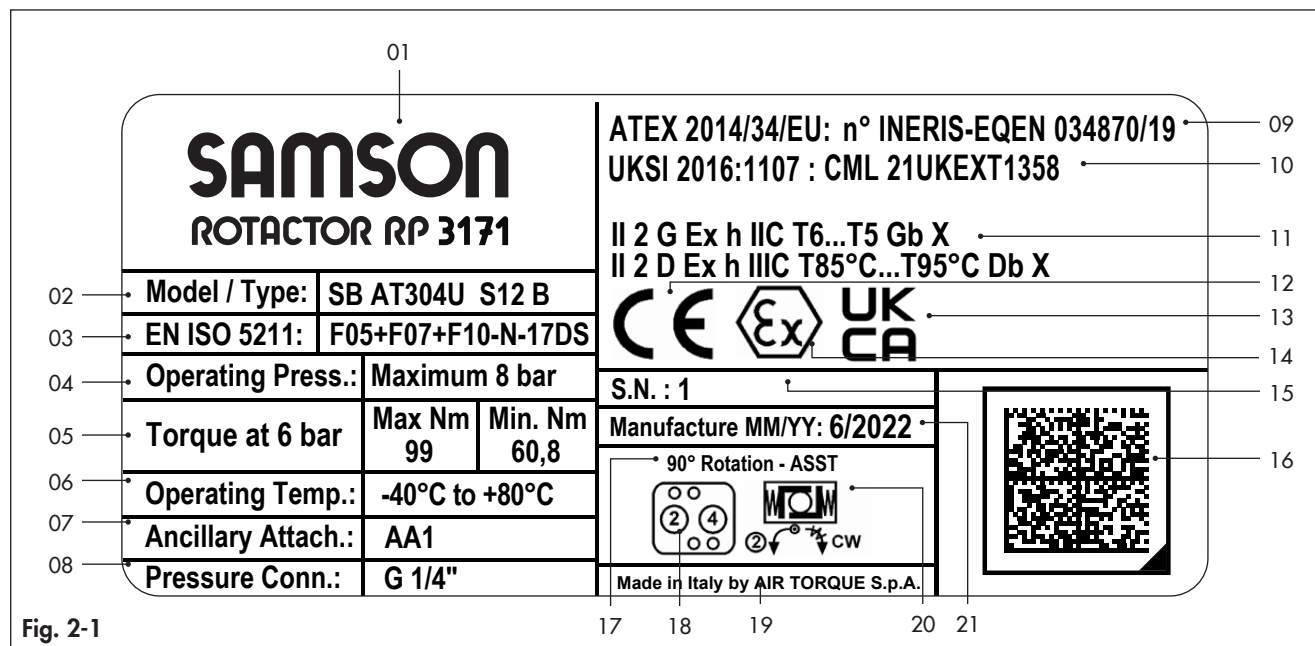

Fig. 2-1

Table 2-1

Position	Description
01	Product series and company logo
02	Actuator model
03	Standard reference and actuator attachment designation
04	Maximum operating pressure
05	Maximum operating pressure
06	Output torque at specified supply pressure in Nm – for Double acting: Max. output torque = Nominal torque at 5,5 bar (Nominal pressure) – for Single acting: Max. output torque = Air Start output torque at specified supply pressure Min. output torque = Spring End output torque
07	Ancillary attachment, interface according to actuator size
08	Pressure connections and interface
09	ATEX technical documentation references
10	UKSI technical documentation references
11	ATEX / UKCA marking
12	CE marking
13	UKCA marking - UKSI 2016:1107 regulation
14	ATEX marking - 2014/34/EU Directive
15	Actuator serial number
16	Data Matrix Code
17	Actuator Rotation and Assembly type
18	Air connections (Port 2 and Port 4 identification)
19	Country of origin and manufacturer's name
20	Action and Rotation – for Double acting: direction of rotation while the actuator is pressurized through Port 2 or Port 4 – for Single acting: direction of rotation while the actuator is pressurized through Port 2 and indication of fail safe direction for spring action
21	Month (MM) / Year (YY) of manufacture

i Note

Refer to the Catalogue T 8325 for actuators available options and ordering codes.

3 Design and principle of operation

The SAMSON ROTACTOR RP 3171 actuators are devices for remote operation (on/off or modulating duties) of different industrial valves such as ball valves, butterfly valves and plug valves.

The actuators are available in two configurations: spring return and double acting.

1. DOUBLE ACTING

Refer to Fig. 3-1.

In case of the double acting configuration air pressure will be necessary for both strokes (A and B).

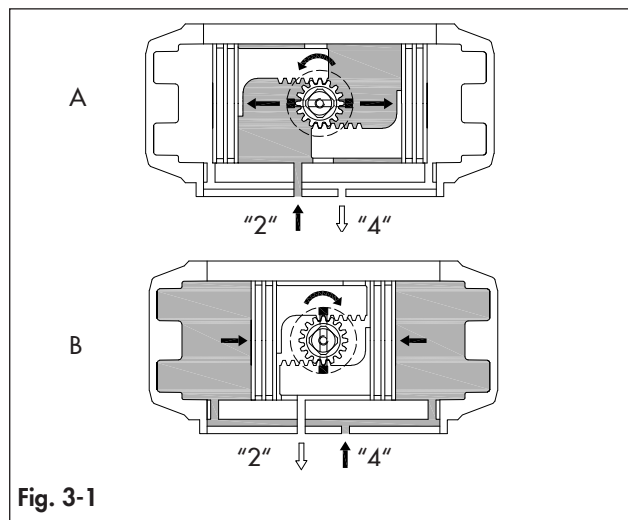

Fig. 3-1

2. SINGLE ACTING

Refer to Fig. 3-2.

When air pressure is supplied through port "2" (A') into the actuator body, the linear force applied on the piston surface generates the pinion rotation, driving the valve to a defined position. At the same time the actuator springs are compressed.

When air pressure is discharged (B'), the springs are automatically released, driving the rack and pistons back to the original position and thus the valve to the fail-safe position.

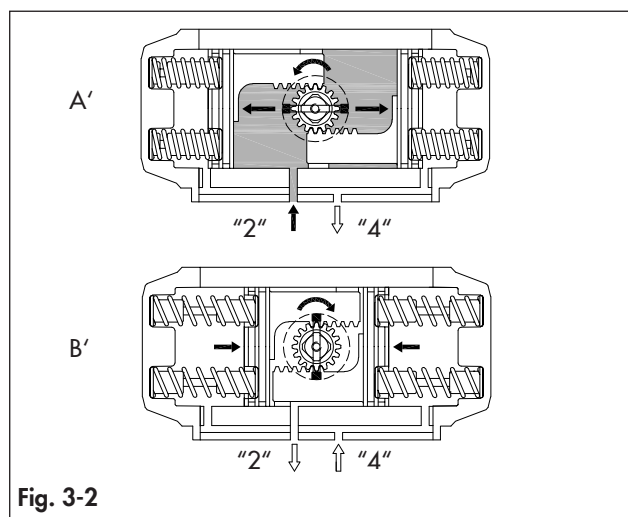

Fig. 3-2

The actuators can be controlled by different options:

- direct mounting of control devices (for example a solenoid valve or a manifold) with NAMUR interface,
- threaded connections (to pressurize port "2" and "4") with air lines from separate electro-pneumatic control system.

3.1 Direction of action and fail positions

The standard rotating direction for the SAMSON ROTACTOR RP 3171 actuators is clockwise to close.

Standard SAMSON ROTACTOR RP 3171 actuators are designed for 90° rotating angle, with travel stop allowing adjustment (Fig. 3-3) for -5° up to +15° on the close position and for +5° up to -15° on the open position. For AT045U stroke adjustment is only available on request.

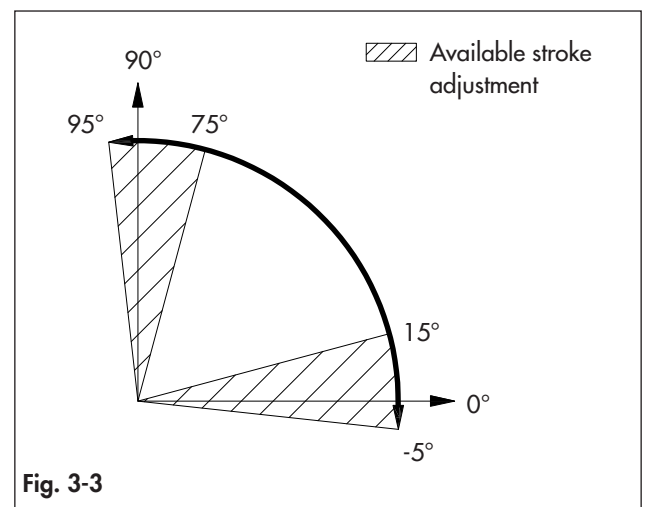

Fig. 3-3

For single acting actuators in case of pressure, power or signal failure the springs drive the actuator in the fail position that can be FAIL OPEN or FAIL CLOSE.

i Note

If the actuator is controlled by a control system the FAIL position may be different from FAIL OPEN or FAIL CLOSE.

- ➔ Refer to the actuator model technical data for the FAIL position.
- ➔ Refer to section 2.1 'Actuator nameplate sample' (Table 2-1, position 11) for the fail action and direction of rotation available options.

3.2 Complementary/accessory parts

Gearbox

It is an emergency manual override system designed to provide manual operation to drive the actuator and the valve in the safe position when the supply pressure is not available in case of any emergency situation. The actuator and the valve are operated rotating a handwheel. (Fig. 3-4)

→ Refer to the gearbox instruction manual available from SAMSON.

NOTICE

Risk of actuator damage due to incorrect gearbox stroke adjustment.

- Make sure that the actuator and the gearbox are correctly oriented, with reference to the rotation direction required.
- Make sure that the stroke of the gearbox does not exceed the stroke allowed by the actuator.

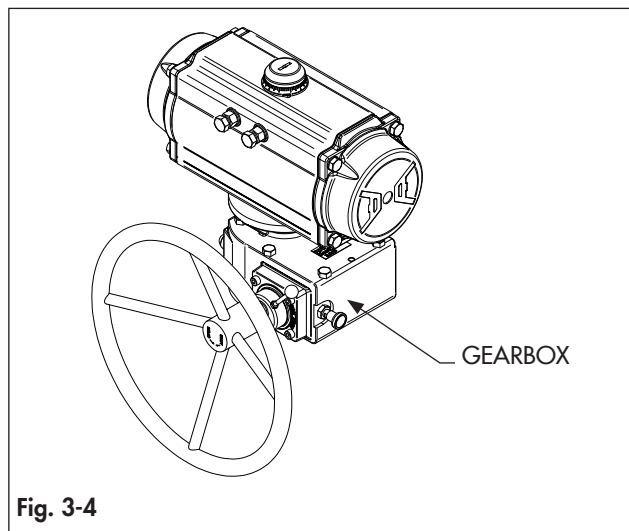

Fig. 3-4

Block and safety lock-out system

The block and safety lock-out system permits to lock the actuator and the valve in specific cases, despite the fail action of the actuator. (Fig. 3-5)

→ Refer to technical data T 8325

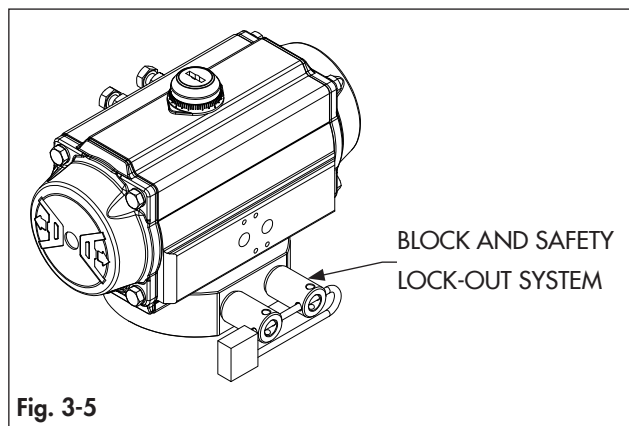

Fig. 3-5

3.3 Technical data

The nameplate provides information on the actuator configuration.

- Refer to section 2.1 'Actuator nameplate sample'.
- More informations are available in the actuator model technical data sheet available from SAMSON.

Power operating media

- Use dry or lubricated air or inert gas.
- Make sure the operating media is compatible with the actuator internal parts and lubricant.
- In case of pressure medium different than Group 2 fluids according to the PED 2014/68/EU, contact SAMSON.
- The operating media must have a dew point equal to -20°C (-4°F) or at least 10°C (18°F) below the ambient temperature.
- The maximum particle size contained into the operating media must not exceed $30\ \mu\text{m}$.

Supply pressure

- The maximum operating pressure is 8 bar (116 Psi).
- Refer to section 2.1 'Actuator nameplate sample' (Table 2-1, position 05).
- For double acting and single acting actuators the working pressure is from 2.5 bar (36 Psi) to 8 bar (116 Psi).
- Refer to the actuator model technical data for output torque values related to the working pressure range.

Operating temperature

The nameplate provides indication on the operating temperatures.

- "ST" actuators for standard temperatures from -40°C (-40°F) to $+80^{\circ}\text{C}$ ($+176^{\circ}\text{F}$).
- "HT" actuators for high temperatures from -15°C ($+5^{\circ}\text{F}$) to $+150^{\circ}\text{C}$ ($+302^{\circ}\text{F}$).
- "LLT2" actuators for extremely low temperatures from -60°C (-76°F) to $+80^{\circ}\text{C}$ ($+176^{\circ}\text{F}$).
- Refer to the data sheet T 8325 for the soft spare parts material and lubricant type in relation to the different working temperature ranges.

Stroking time

The stroking time depends on several factors such as supply pressure, supply system capacity (tubing diameter, pneumatic accessories flow capacity), valve type, valve torque, applied safety factor, cycle frequency, temperatures, etc. Nevertheless, an indication of the stroking time in clearly defined conditions is available in the actuator model technical data sheet.

4 Shipment and on-site transport

The work described in this section is only to be performed by fully trained and qualified personnel.

4.1 Accepting the delivered goods

After receiving the shipment, proceed as follows:

1. Check the scope of delivery. Check that the specifications on the actuator nameplate match the specifications in the delivery note. See the 'Markings on the device' section for nameplate details.
2. Check the shipment for transportation damage. Report any damage to SAMSON and the forwarding agent (refer to delivery note).
3. Determine the weight and dimensions of the units to be lifted and transported in order to select the appropriate lifting equipment and lifting accessories. Refer to the transport documents and to the actuator model Technical data sheet.

4.2 Removing the packaging from the actuator

Do not open or remove the packaging until immediately before mounting the actuator.

Leave the actuator in its transport container or on the pallet to transport it on site.

Dispose and recycle the packaging in accordance with the local regulations.

4.3 Transporting and lifting the actuator

⚠ DANGER

Risk of severe personal injury due to suspended loads falling.

- Stay far from suspended or moving loads.
- Close off and secure the transport parths.

⚠ WARNING

Risk of lifting equipment tipping over and risk of damage to lifting accessories due to exceeding the rated lifting capacity.

- Use only approved lifting equipment and accessories whose maximum lifting capacity is higher than the actuator weight (including the packaging, if applicable).

ⓘ NOTICE

Risk of actuator damage due to incorrectly attached slings.

Only attach load slings to vertically lift the actuator on its own. The lifting points must not be used to lift the actuator and valve assembly.

- Do not attach load-bearing slings to the travel stop or to accessories.
- Do not use damaged or defective slings.

- Do not shorten the slings with knots or bolts or other makeshift devices.
- Observe lifting instructions (see section 4.3.2).

💡 Tip

Our after-sales service can provide more detailed transport and lifting instructions on request.

4.3.1 Transporting the actuator

The actuator can be transported using proper lifting equipment (e.g. crane or forklift).

- Leave the actuator in its transport container or on the pallet to transport it.
- Observe the transport instructions.

Transport instructions

- Protect the actuator against external influences (e.g. impact).
- Do not damage the corrosion protection (paint, surface coatings). Repair any damage immediately.
- Protect the actuator against moisture and dirt.
- Observe permissible temperatures (refer to the section 3.3 'Technical data').

4.3.2 Lifting the actuator

Observe the ruling regulations concerning the lifting operations.

To mount large actuators onto the valve, use lifting equipment (e.g. crane or forklift) to lift it.

Do not drill extra holes into the actuator.

Do not use the actuator lifting points to lift the actuator and valve assembly.

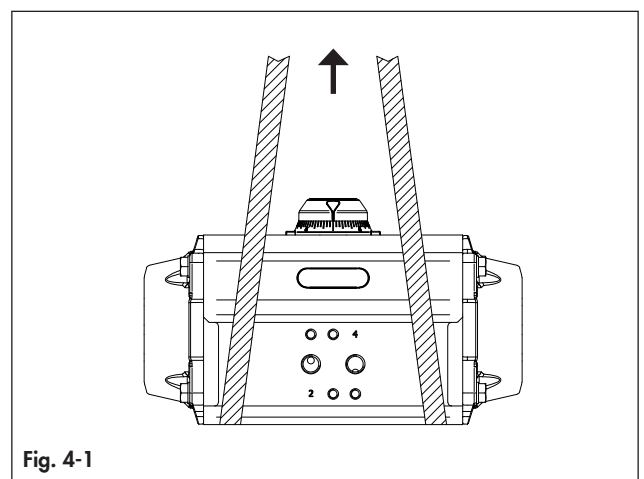

Fig. 4-1

Use appropriate tackles and slings to lift the actuator.

- Refer to technical data sheet for the actuator weight.

Lifting instructions

- Secure slings on the object to be transported against slipping.
- Make sure the slings can be removed from the actuator once it has been mounted on the valve.
- Prevent the actuator from tilting or tipping.
- Do not leave loads suspended when interrupting work for longer periods of time.
- Use a hook with safety latch to secure the slings from slipping during lifting and transporting.
- For models bigger than AT651U two threaded holes are available to lift the actuator by means of eyebolts or similar components as shown in Fig. 4-2. Do not lift the actuator and valve assembly from these lifting points.

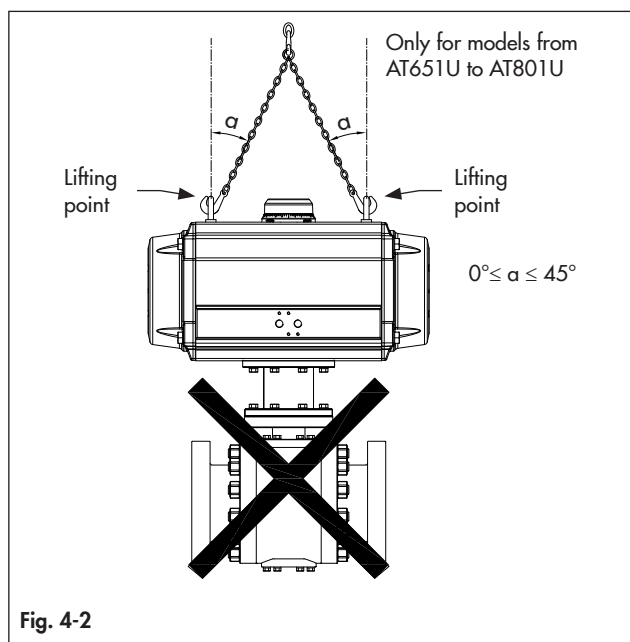

- Refer to the 'Rubber components storage instruction' (T 3.3.3.1 EN).
- When the valve and actuator are already assembled, also observe the valve storage conditions. Refer to the valve documentation.
- Protect the actuator against external influences (e.g. impact).
- Secure the actuator in the stored position against slipping or tipping over.
- Do not damage the corrosion protection (paint, surface coatings). Repair any damage immediately.
- Protect the actuator against moisture and dirt.
- Make sure that the ambient air is free of acids or other corrosive media.
- Do not place any objects on the actuator.
- Keep for future references the relevant technical documentation of the actuator.
- Do not remove the plastic plugs from the air connections.

Tip

Our after-sales service (samson@samsongroup.com) can provide more detailed storage instructions on request.

4.4 Storing the actuator

NOTICE

Risk of actuator damage due to improper storage.

- Observe the storage instructions.
- Observe the rubber components storage instructions (T 3.3.3.1 EN).
- Avoid long storage times. Contact SAMSON in case of different storage conditions or long storage periods.

Note

It is recommended to regularly check the actuator and the prevailing storage conditions during long storage times.

Storage instructions

- Store the actuator in a clean and dry place.
- Temperature limits are defined by the rubber components material.

5 Mounting and assembly

The work described in this section is only to be performed by fully trained and qualified personnel.

5.1 Preparation for installation

If the actuator was shipped already assembled over the valve, the setting of the actuator and control system (if any) should have been already done by the valve manufacturer or automation center.

If the actuator was shipped separately from the valve, the setting of the actuator and control system must be done while assembling the actuator on top of the valve.

The actuator assembly on valve can be performed by:

- Mounting directly the actuator over the valve interface
- Assembling a bracket and a coupling between the actuator and the valve.

5.2 Control and signal devices assembly

The SAMSON ROTACTOR RP 3171 actuators can be controlled by directly mounted devices or remote control systems. Therefore SAMSON actuators have direct mounting interfaces (Fig. 5-1) in order to allow control and signal devices assembly (e.g. solenoid valve, positioner, switchbox, etc) and threaded connections for remote control systems.

- ➔ Refer to the documentation available from control and signal devices manufacturers for mounting and operating instructions.

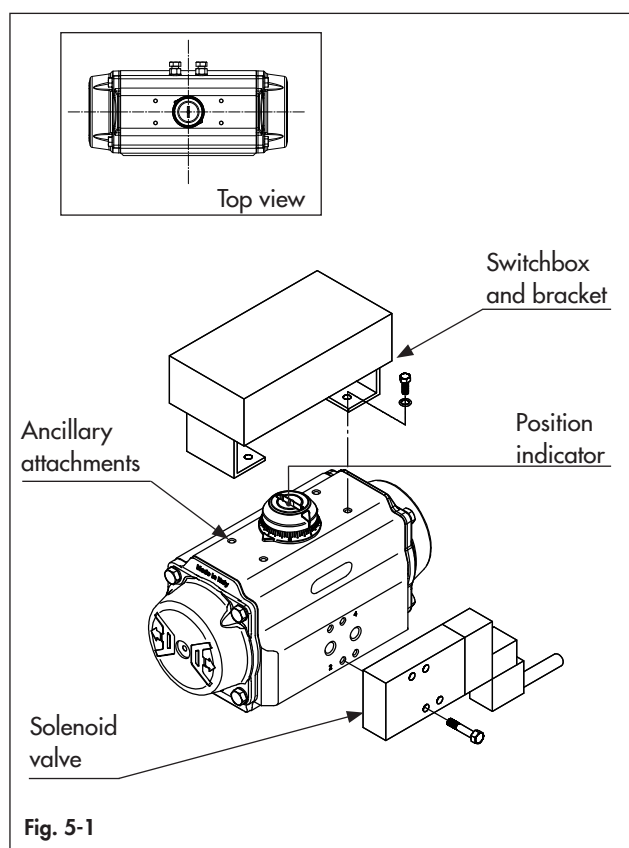

Fig. 5-1

5.3 Mounting the actuator over the valve

⚠ DANGER

Risk of bursting in the actuator

Pneumatic actuators are pressure equipment that may burst when handled incorrectly. Flying projectile fragments or components can cause serious injury or even death.

- ➔ Before starting any work on the actuator disconnect all pneumatic / hydraulic / electrical supplies and discharge the pressure from the actuator.

⚠ WARNING

Crush hazard arising from moving parts.

The actuator and the valve assembly contains moving parts, which can injure hands or fingers.

- ➔ Do not touch or insert hands or finger into moving parts.
- ➔ Before starting any work on the actuator disconnect all pneumatic / hydraulic / electrical supplies and discharge the pressure from the actuator.
- ➔ Do not impede the movement of the pinion and the pistons by inserting objects into the actuator.

⚠ WARNING

Risk of damage and malfunction due to torque limit violation.

Considering the maximum actuator output torque, the maximum air supply pressure and the maximum valve torque, according to ISO 5211, the actuator maximum transmissible output torque must not exceed the torque limit in relation to the available ISO flange and the drive shaft connection.

- ➔ Refer to section 2 'Markings on the device' for nameplate details.

⚠ WARNING

Risk of personal injury due to preloaded and compressed springs.

End caps are under tension due to compressed springs.

Furthermore incorrect spring cartridges disassembly could result in serious injury.

- ➔ Before starting any work on the actuator disconnect all pneumatic / hydraulic / electrical supplies and discharge the pressure from the actuator.
- ➔ Make sure that the actuator is in the closed position (0°).

ⓘ NOTICE

Risk of actuator damage due to excessively high or low tightening torques.

Observe the specified torques on tightening actuator components (bolts and nuts). Excessive tightening torques lead to parts wearing out quicker. Parts that are not tightened enough may loosen.

- ➔ Refer to section 15.2 'Tightening torques'.

Mounting and assembly

Before mounting the actuator over the valve, make sure the following conditions are met:

- The actuator is not damaged.
- The type designation, material and temperature range of the actuator match the ambient conditions (temperatures etc.). Refer to 'Markings on the device' in section 2 for nameplate details.
- Check compatibility of the valve stem to the actuator bore. The length, size and configurations must match.
- Check compatibility of actuator, valve and bracket bolting pattern.
- Before fitting the actuator over the valve, make sure that the actuator and the valve are correctly oriented, with reference to the rotation direction and fail action required.
- Make sure that the tubing, fittings and seals connected to the actuator are cleaned to prevent foreign matter/objects entering into the actuator's chambers.

- When fitting accessories over the actuators, assemble them in such a way that the emergency controls are easily accessible for emergency manual operation.
- Check that the exhaust ports are not obstructed.
- Remove the plugs from the actuator air connections during installation and operation, protect and close the air connections which may not be used immediately.
- Make sure that the operating pressure media composition used for the actuator operation meets the operating conditions given in this manual and corresponds to what the actuator was manufactured for. Refer to section 3 'Design and principles'.
- It is the user responsibility to ensure that actuator and control components must be protected from electrical spikes, surge and lightning strikes as well as all magnetic fields.
- Prevent any dangerous and/or corrosive substances in the working environment enter into the internal chambers by using adequate filters and/or solenoid valves and/or any other appropriate system.

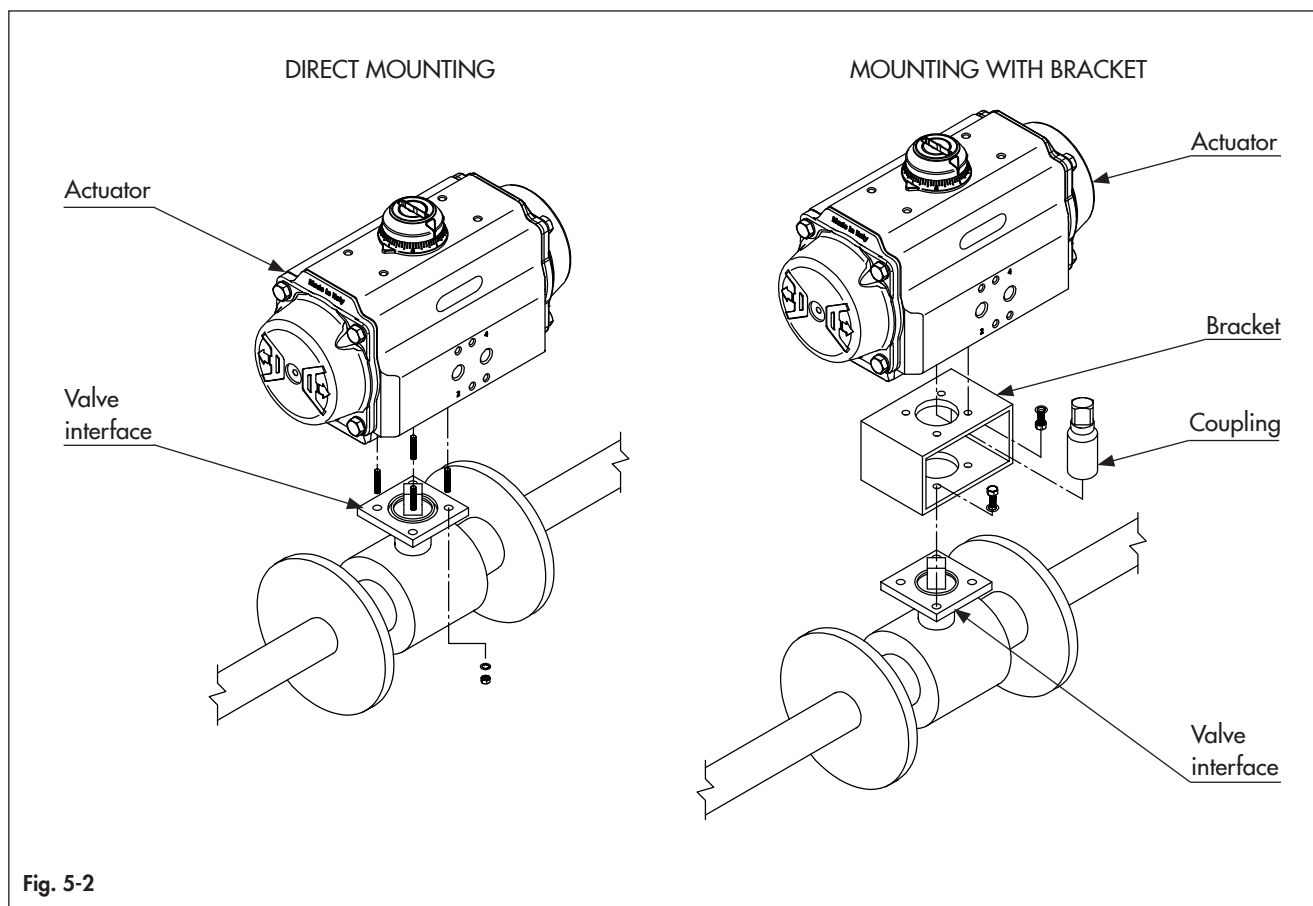

Fig. 5-2

Refer to Fig. 5-2 and proceed as follows to mount the actuator over the valve:

1. Disconnect any electrical/pneumatic/hydraulic power supply.
2. Lay out the necessary material and tools to have them ready during mounting.
3. The actuator is supplied in the fail position (for single-acting), so drive the valve in the right position as per the actuator fail position.
4. Clean the actuator's bore and the bottom flange.
5. Clean the valve and the actuator interface to remove completely any lubricant.

6. Place the bracket, if any, over the valve flange, tighten all bolts and nuts and apply the correct tightening torque.
7. Assemble the coupling at first into the valve stem before the assembly of the actuator.
8. Lift the actuator.

⚠ WARNING***Risk of damage due to incorrect alignment***

- *Support the actuator with the lifting equipment until the connection bolts are completely tightened.*
- *Make sure to align correctly the dowel pins or the spigot, if any.*

-
9. Align the valve stem/coupling to the actuator's bore.
 10. Carefully lower the actuator and engage the valve stem/coupling into the actuator's bore without forcing and driving the actuator into the position only with the weight of the actuator itself.
 11. Fix the actuator over the valve flange/bracket with the connection bolts.
 12. Tighten the connection bolts at the correct tightening torque as per ISO 5211.

6 Start-up

The work described in this section is only to be performed by fully trained and qualified personnel.

⚠ WARNING

Risk of personal injury during actuator air exhaust.

In case of pneumatic version the actuator is operated with air. As a result, air is exhausted during operation.

- ➔ *Install the air exhaust components in such a way that exhaust ports are not located at eye level and the actuator does not discharge at eye level in the work position.*
 - ➔ *Use suitable silencers and vent plugs.*
 - ➔ *Wear eye and hearing protection when working near the actuator.*
-

⚠ WARNING

Risk of personal injury through incorrect operation, use or installation as a result of information on the actuator being illegible.

Over time, markings, labels and nameplates on the actuator may become covered with dirt or become illegible in some other way. As a result, hazards may go unnoticed and the necessary instructions not followed. There is a risk of personal injury.

- ➔ *Keep all relevant markings and inscriptions on the device in a constantly legible state.*
 - ➔ *Immediately renew damaged, missing or incorrect nameplates or labels.*
-

Verify the compatibility and connect the actuator to the pressure supply line and/or to the control system, if any, with fittings and pipes as per actuator model and plant specifications.

7 Operation

The work described in this section is only to be performed by fully trained and qualified personnel.

⚠ WARNING

Risk of personal injury during actuator air exhaust.

In case of pneumatic version the actuator is operated with air. As a result, air is exhausted during operation.

- Install the air exhaust components in such a way that exhaust ports are not located at eye level and the actuator does not discharge at eye level in the work position.
- Use suitable silencers and vent plugs.
- Wear eye and hearing protection when working near the actuator.

⚠ WARNING

Crush hazard arising from moving parts.

The actuator and the valve assembly contains moving parts, which can injure hands or fingers.

- Do not touch or insert hands or finger into moving parts.
- Before starting any work on the actuator disconnect all pneumatic / hydraulic / electrical supplies and discharge the pressure from the actuator.
- Do not impede the movement of the pinion and the pistons by inserting objects into the actuator.

⚠ WARNING

Risk of personal injury through incorrect operation, use or installation as a result of information on the actuator being illegible.

Over time, markings, labels and nameplates on the actuator may become covered with dirt or become illegible in some other way. As a result, hazards may go unnoticed and the necessary instructions not followed. There is a risk of personal injury.

- Keep all relevant markings and inscriptions on the device in a constantly legible state.
- Immediately renew damaged, missing or incorrect nameplates or labels.

⚠ WARNING

Risk of bursting due to pressurized external chambers of spring return actuator, "Port 4" air connection.

Spring Return Pneumatic actuators are pressure equipment that may burst when pressurized incorrectly in the spring chambers. Flying projectile fragments or components can cause serious injury or even death.

- Only the internal chamber, "Port 2" air connection, of spring return actuators must be pressurized.
- Refer to section 3 "Design and principle of operation" for the function details.
- The use of close loop system is allowed.

The actuator can be operated after connecting it to the supply line and adjusting the stroke.

Spring return actuators work on air stroke or spring stroke by pressurizing or venting respectively the connection ports.

Double acting actuators require alternate connection ports to be pressurized and vented for stroking.

- Refer to section 3 'Design and principle of operation'.
- Choose the accessories, control elements, tubing and fittings for adequate flow rates so as not to constrict flow or cause high pressure drop affecting the performance of the actuator.
- In case the plant specifications require a supply pressure for the actuator lower than the maximum supply pressure marked in the actuator nameplate, label the actuator with reduced supply pressure (e.g. "Max. supply pressure limited to ... bar").

8 Malfunctions

The work described in this section is only to be performed by fully trained and qualified personnel.

8.1 Troubleshooting

Malfunction	Possible reasons	Reccomended action
Uneven rotation	Inadeguate supply	Check the supply system and make sure that the supply pressure is correct.
	Missing lubricant	Disassemble the actuator, lubricate all the sliding parts and reassemble the actuator.
	Worn components	Disassemble the actuator, inspect and replace the worn/damaged components.
	Control system	Make sure the control system components are correctly assembled. Check the control system documentation and contact the manufacturer.
	Faulty valve	In case of actuator mounted over the valve, check the valve documentation and contact the manufacturer.
Incomplete rotation	Incorrect stroke adjustment	Follow the indications in section 9.5.6 for correct stroke adjustment.
	Foreign object left inside	Disassemble the actuator, inspect and remove any foreign object.
	Incorrect assembly after maintenance	Disassemble and reassemble the actuator correctly.
	Control system	Make sure the control system components are correctly assembled. Check the control system documentation and contact the manufacturer.
	Faulty valve	In case of actuator mounted over the valve, check the valve documentation and contact the manufacturer.
Loss of power	Inadeguate supply pressure	Check the control system and make sure that the supply pressure is correct.
	Supply pipe blocked, compressed or with sealing problems	Check all the tubing and fittings, remove any foreign object/damaged component.
	Actuator seals leakage	Disassemble the actuator, inspect and replace any damaged seals.
	blocked air exhaust hole	Remove plugs or foreign objects from the exhaust hole.
	Faulty valve	In case of actuator mounted over the valve, check the valve documentation and contact the manufacturer.

i Note

Contact SAMSON after-sales service (samson@samsongroup.com) for malfunctions not listed in the table.

8.2 Emergency action

The plant operator is responsible for emergency action to be taken in the plant.

9 Service

The work described in this section is only to be performed by fully trained and qualified personnel.

⚠ DANGER

Risk of bursting due to incorrect opening of pressurized equipment or components.

Pneumatic actuators are pressure equipment that may burst when handled incorrectly. Flying projectile fragments or components can cause serious injury or even death.

- ➔ Before starting any work on the actuator disconnect all pneumatic / hydraulic / electrical supplies and discharge the pressure from the actuator.

⚠ WARNING

Risk of personal injury due to preloaded and compressed springs.

End caps are under tension due to compressed springs. Furthermore incorrect spring cartridges disassembly could result in serious injury.

- ➔ Before starting any work on the actuator disconnect all pneumatic / hydraulic / electrical supplies and discharge the pressure from the actuator.
- ➔ Make sure that the actuator is in the closed position (0°) while disassembling the end caps and the stop screws have been correctly removed.
- ➔ Do not disassemble individual spring cartridges.
- ➔ If spring cartridges service is necessary, contact SAMSON.

⚠ WARNING

Crush hazard arising from moving parts.

The actuator and the valve assembly contains moving parts, which can injure hands or fingers.

- ➔ Do not touch or insert hands or finger into moving parts.
- ➔ Before starting any work on the actuator disconnect all pneumatic / hydraulic / electrical supplies and discharge the pressure from the actuator.

ⓘ NOTICE

Risk of actuator damage due to excessively high or low tightening torques.

Observe the specified torques on tightening actuator components (bolts and nuts). Excessive tightening torques lead to parts wearing out quicker. Parts that are not tightened enough may loosen.

- ➔ Observe the specified tightening torques in section 1.5.2.

ⓘ Note

- The product warranty becomes void if service or repair work not described in these instructions is performed without prior agreement by SAMSON's After-sales Service.
- Only use original spare parts by SAMSON, which comply with the original specifications.

With the information given below, SAMSON provides the end user with all the required information necessary for service.

Under normal conditions, the actuator requires only periodic observation to ensure proper operation. However, due to critical working conditions and a natural components ageing effect even if properly stored, a preventive service program is essential to ensure good performance, safe operation and an extended life of the actuator. SAMSON recommend to perform the service not later than reaching the first limit between cycles number limit and time limit. One cycle consists of nominal 90° angular travel in both directions (i.e. 90° to open + 90° to close).

- ➔ Spare kits are available for seals and bearing replacement. (refer to the 'Part list' in section 9.2)
- ➔ Refer to the Rubber products storage instructions (T3.3.3.1 EN).

Table 9-1

ACTUATOR OUTPUT TORQUE RANGE	CYCLES NUMBER LIMIT	TIME LIMIT
Up to 125 Nm	500.000	48 Months/ 4 years from installation or 60 Months/5 years from production date.
125 Nm ÷ 500 Nm	350.000	
500 Nm ÷ 1000 Nm	250.000	
1000 Nm ÷ 3000 Nm	100.000	
3000 Nm ÷ 8000 Nm	50.000	
8000 Nm ÷ 16000 Nm	30.000	

Cycles number limit and time limit have been defined for actuators with sizing safety factor at least 1.3 and operating at specific conditions:

- Supply pressure ≤ 5,5 bar.
- Supply media: air or inert gas, not corrosive, dry or lightly lubricated, without impurity.
- Working temperature from 10°C up to 30°C.

ⓘ Note

Any deviation from these operating conditions may affect the recommended cycles number limit and time limit.

- ➔ For actuators with "HT" or "LLT2" operating temperatures (refer to section 3.3 'Technical data') the recommended cycles number and time limit may be reduced by 50%.
- ➔ For actuators operating in Safety instrumented systems where a certain SIL level is required, cycles number limit and time limit may be significantly reduced.

9.1 Preparation for servicing

1. Lay out the necessary material and tools to have them ready for the intended work.
2. Put the actuator out of operation referring to section 10 'Decommissioning'.
3. Remove the actuator from the valve referring to section 11 'Removal'.

9.2 Part list

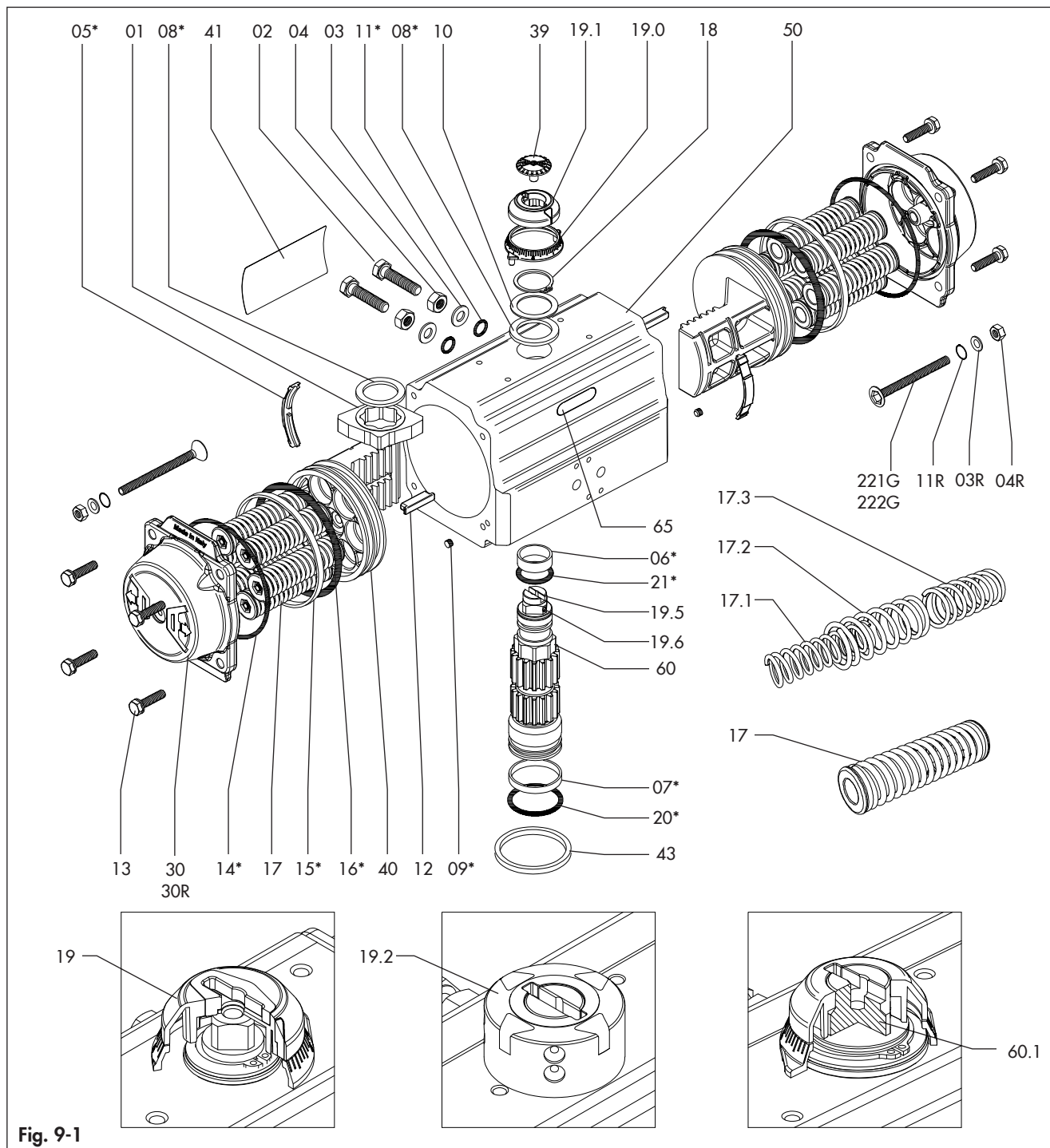

Fig. 9-1

Table 9-2

PART N° 1)	UNIT Q.TY	NOTE	DESCRIPTION
01	1	N.A. for AT045U	OCTI-CAM (Stop arrangement)
02	2	N.A. for AT045U	STOP CAP SCREW
03	2	N.A. for AT045U	WASHER
03R	2	for models with extra travel stop adjustment	WASHER
04	2	N.A. for AT045U	NUT (Stop screw)
04R	2	for models with extra travel stop adjustment	NUT (Extra travel stop adjustment screw)
05*	◇ 2		BEARING (Piston back)

PART N° 1)		UNIT Q.TY	NOTE	DESCRIPTION
06*	◇	1		BEARING (Pinion top)
07*	◇	1		BEARING (Pinion bottom)
08*	◇	2	1 pcs for AT045U	THRUST BEARING (Pinion)
09*	◇ •	2	N.A. for AT801U	PLUG
09.1*	◇ •	2		O-RING (For AT801U)
10		1		THRUST WASHER (Pinion)
11*	◇ •	2	N.A. for AT045U	O-RING (Stop screw)
11R*	◇ •	2	for models with extra travel stop adjustment	O-RING (Extra travel stop adjustment screw)
12		2	N.A. for AT045U	PISTON GUIDE
13 2)		8/12/16		CAP SCREW (End cap)
14*	◇ •	2		O-RING (End cap)
15*	◇	2		BEARING (Piston head)
16*	◇ •	2		O-RING (Piston)
17		min. 5/ max. 12		SPRING (Cartridge)
17.1		max. 2 for AT045U max. 2 for AT051U		SPRING (for AT045U ÷ AT051U)
17.2				SPRING (for AT045U ÷ AT051U)
17.3				SPRING (for AT045U ÷ AT051U)
18		1		SPRING CLIP (Pinion)
19		1		POSITION INDICATOR (for AT045U ÷ AT101U)
19.0		1		GRADUATED RING
19.1		1	N.A. for AT045U ÷ AT101U	POSITION INDICATOR
19.2 3)		1		MULTIFUNCTION POSITION INDICATOR
19.5		1	N.A. for AT045U ÷ AT101U	TOP ADAPTER (Drive shaft)
19.6		2	N.A. for AT045U ÷ AT101U	HEX. SOCKET SCREW (Top adapter)
20*	◇ •	1		O-RING (Pinion bottom)
21*	◇ •	1		O-RING (Pinion top)
30		2		END CAP
39		1		CAP SCREW (Indicator)
40		2		PISTON
41		1		ACTUATOR IDENTIFICATION LABEL
42		2	only for AT045U and AT751U	END CAP LABEL
43 3)		1		SPIGOT
50		1		BODY
60		1		DRIVE SHAFT
60.1		1		INTEGRAL DRIVE SHAFT
65		1		PLASTIC INSERT
221G		2	for models with 50% extra travel stop adj.	STOP SCREW (Extra travel stop adjustment)
222G		2	for models with 100% extra travel stop adj.	STOP SCREW (Extra travel stop adjustment)

NOTES:

- 1) * Suggested spare parts.
 Components included in spare part kits are indicated as follows:
 ◇ included in complete spare parts kit
 • included in o-rings kit
- 2) 8 for AT045U ÷ AT101U; 12 for AT701U ÷ AT751U; 16 pcs for AT801U
- 3) Available on request.

9.3 Disassembly

→ Refer to the Fig. 9-1 and Table 9-2 for parts list.

9.3.1 Position indicator and graduated ring removal

Refer to Fig. 9-1 and Fig 9-2.

- Remove cap screw (39), if any.
- Lift the position indicator (19/19.1) off the top drive shaft. If necessary pry gently with a screwdriver.
- Lift the graduated ring (19.0) off the body, if any. If necessary pry gently with a screwdriver.

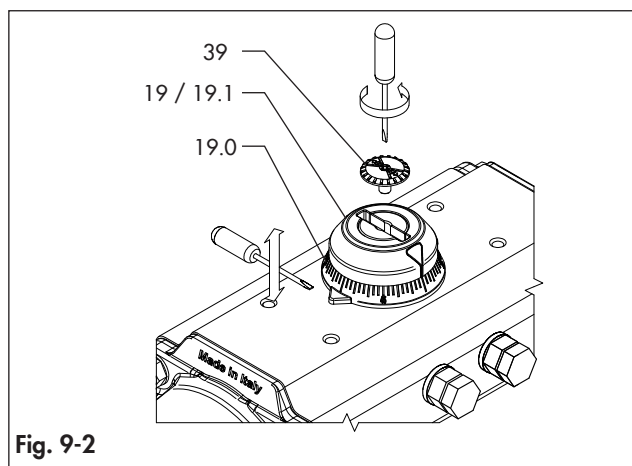

Fig. 9-2

9.3.2 Stop cap screws removal

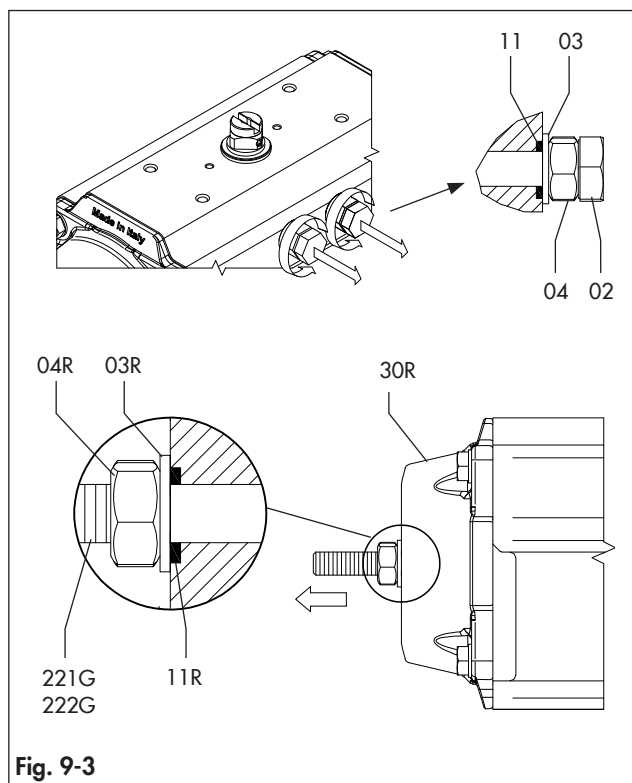

Fig. 9-3

Refer to Fig. 9-1 and Fig 9-3.

- Remove both stop cap screws (02) together with nuts (04) and washers (03).
- Remove the stop caps o-rings (11).

In case of actuator with extra travel stop adjustment (Fig. 9-3):

- loosen the nut (04R),
- unscrew partially the stop screw (221G/222G) out from the actuator, making sure that the stop screw (221G/222G) is not in contact with the piston anymore.

9.3.3 End caps disassembly

Refer to Fig. 9-1, Fig 9-4 and Fig 9-5.

Disassemble one end cap at a time.

⚠ WARNING

Risk of personal injury due to compressed springs.

End caps are under tension due to compressed springs.

- Before starting any work on the actuator disconnect all pneumatic / hydraulic / electrical supplies from the actuator and exhaust the pressure from the power module.
- Make sure that the actuator is in the closed position (0°) before disassembling.
- Make sure that the stop cap screws (02) have been correctly removed as per section 9.3.2.

ⓘ NOTICE

Risk of components damage due to incorrect disassembly.

During disassembly the end caps can be damaged due to uneven force generated by compressed springs.

- Remove the end caps as shown in Fig. 9-4 keeping a constant distance ($A = B$) between the actuator body and the end cap interface.
- Observe the specified sequence shown in Fig. 9-5.

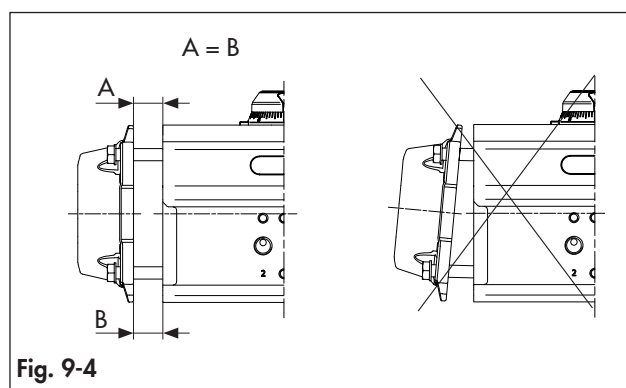
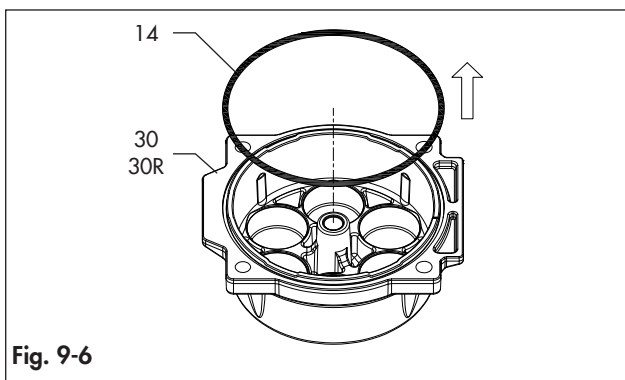
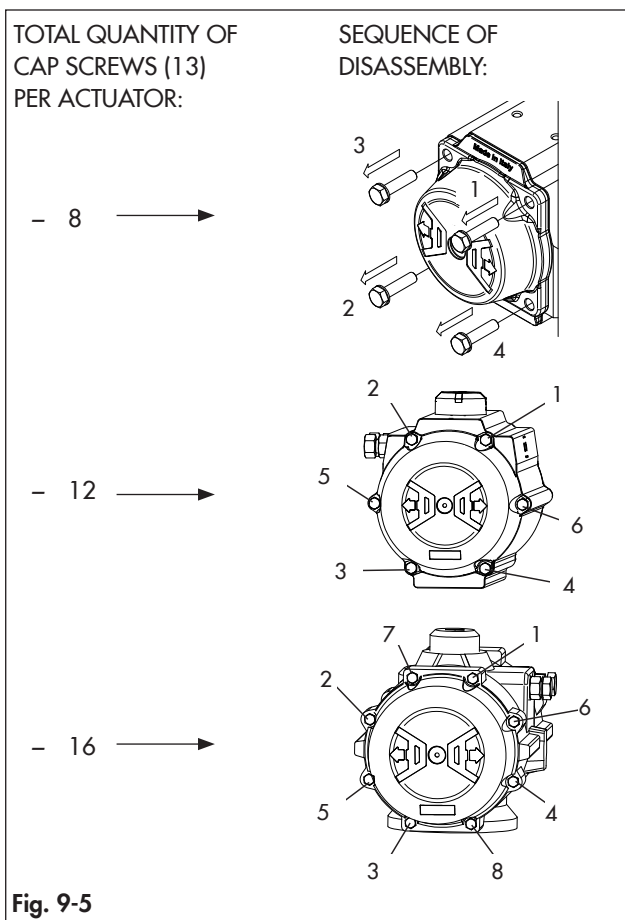

Fig. 9-4



Spring return actuators

- Release the springs compression by partially unscrewing each end cap bolt (13) 1 turn at a time as per the sequence shown in Fig. 9-5 for the number of turns indicated in Table 9-2.

⚠ WARNING

Risk of personal injury due to compressed springs.
 End caps are under tension when the springs are compressed.
 → If there is still force on the end cap (30/30R) after unscrewing the cap screws (13) for the number of turns indicated in Table 9-3, the spring cartridge may have been damaged or the pistons are not completely closed: stop the disassembly and contact SAMSON.

Table 9-3

ACTUATOR MODEL	NUMBER OF TURNS FOR SCREWS (13)
AT045U	16 ÷ 18 turns
AT051U	26 ÷ 28 turns
AT101U	5 ÷ 7 turns
AT201U	
AT251U	
AT301U	
AT351U	
AT401U	
AT451U	
AT501U	6 ÷ 8 turns
AT551U	
AT601U	
AT651U	8 ÷ 10 turns
AT701U	
AT751U	
AT801U	

- Completely unscrew and remove the end cap bolts (13)
- Remove the end caps (30).
- Remove the spring cartridges (17).
- Remove the o-rings (14). (Fig. 9-6)

Double acting actuators

- Unscrew completely the end cap bolts (13) as per the sequence shown in the Fig. 9-5.
- Remove the end caps (30).
- Remove the o-rings (14). (Fig. 9-6)

9.3.4 Pistons disassembly

Refer to Fig. 9-1 and Fig. 9-7.

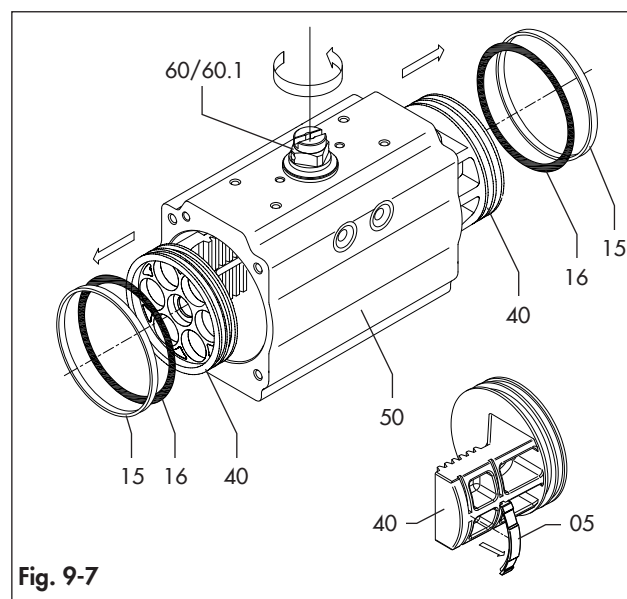

- Holding the body (50) with a bench vice or a similar device, rotate the drive shaft (60/60.1) until the pistons (40) are disengaged.
- Remove o-rings (16), the piston backs (05) and the piston head bearings (15).

9.3.5 Drive shaft disassembly

Refer to Fig. 9-1 and Fig 9-8.

NOTICE

Risk of spring clip damage due to incorrect disassembly.
During disassembly the spring clip (18) can get overstressed if not carefully handled.

- ➔ Use proper tools to disassemble the spring clip.
- ➔ In case of spiral spring clip (18) refer to the disassembly and reassembly instructions available from SAMSON.

- Remove the spring clip (18) by means of snap-ring pliers or a screwdriver for spiral rings.
- Remove the thrust washer (10) and the external thrust bearing (08).
- Apply downward force to the top of the drive shaft (60/60.1), until it is partially out of the bottom of the body and remove the internal thrust bearing (08) and the octi-cam (01).
- Push the drive shaft (60) completely out of the body. If needed, gently tap the top of the drive shaft (60) with a plastic hammer.
- Remove the drive shaft top bearing (06) and bottom bearing (07).
- Remove the drive shaft top o-ring (21) and bottom o-ring (20).

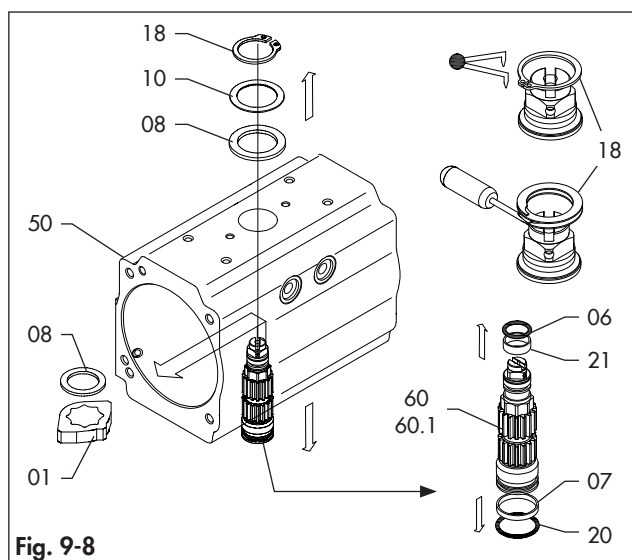

Fig. 9-8

9.4 Service operations

Inspect and clean every single component.
Inspect, clean and replace bolts and nuts, if needed.

Discard and replace the damaged soft components available in the spare parts kit.

- ➔ Refer to the spare parts kit data sheet [T 8325] and to the Rubber products storage instructions [T 3.3.3.1 EN].

Clean and lubricate every o-ring housing.

- ➔ Refer to the section 15.3 'Lubricants'.

9.5 Reassembly

Proceed as follows for the standard assembly of SAMSON ROTACTOR RP 3171 actuators (AS-ST code indicated in the nameplate).

- ➔ Refer to the technical data sheet T 8325 in case of actuators with different function/rotation.
- ➔ Refer to the Catalogue T 8325 for actuators different assembly codes.

NOTICE

Risk of actuator damage due to the use of unsuitable lubricants.

The lubricants to be used depend on the actuator material and operating temperatures.

- ➔ Only use lubricants approved by SAMSON. Refer to section 15.3 'Lubricants'.

9.5.1 Drive shaft reassembly

Refer to Fig. 9-1, Fig. 9-9, Fig. 9-10 and Fig. 9-11.

- Place the drive shaft top bearing (06) and bottom bearing (07).
- Lubricate and place the drive shaft top o-ring (21) and bottom o-ring (20).
- Lubricate the external surface of the bearings and o-rings placed onto the drive shaft (60/60.1) as per the Fig. 9-9.

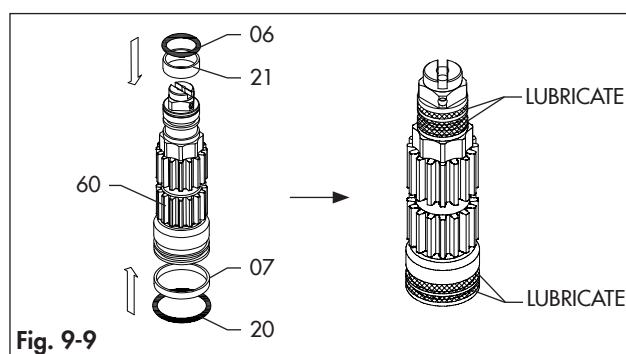

Fig. 9-9

- Insert partially the drive shaft (60/60.1) into the body (50). (Fig. 9-9)
- Place the octi-cam (01) through the body (50) onto the drive shaft (60/60.1). Refer to the Fig. 9-11 for the correct placement of the octi-cam (01) depending on the actuator assembly configuration.
- Place the internal thrust bearing (08).
- Insert completely the drive shaft (60/60.1) into the body (50).

- Place external thrust bearing (08) and thrust washer (10).

NOTICE

Risk of spring clip damage due to incorrect assembly.

During reassembly the spring clip (18) can get overstressed if not carefully handled.

- Use proper tools to reassemble the spring clip.
- Replace the spring clip (18) if it has been overstressed and loosened.
- In case of spiral spring clip (18) refer to the disassembly and reassembly instructions available from SAMSON.

- Place the spring clip (18) by means of by means of snapping pliers or a screwdriver for spiral rings.

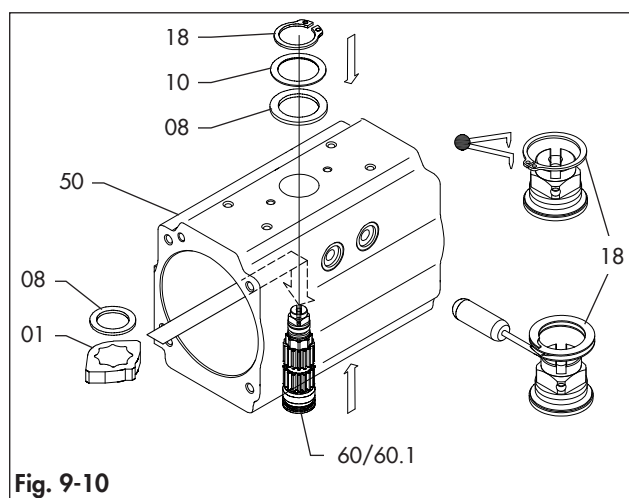

Fig. 9-10

- Lubricate the internal surface of the body (50) and the piston (40) rack teeth.
- Insert the female connection of the drive shaft (60/60.1) in a properly fixed coupling joint. (Fig. 9-13)
- Make sure that the octi-cam (01) is in the right position as per the Fig. 9-13.
- Rotate the body (50) about 40°-45° clockwise from top view, as shown in Fig. 9-14.
- Insert and press the two pistons (40) simultaneously inside the body (50) until the pistons are engaged.
- Then rotate the body (50) anticlockwise from top view until the stroke is completed.

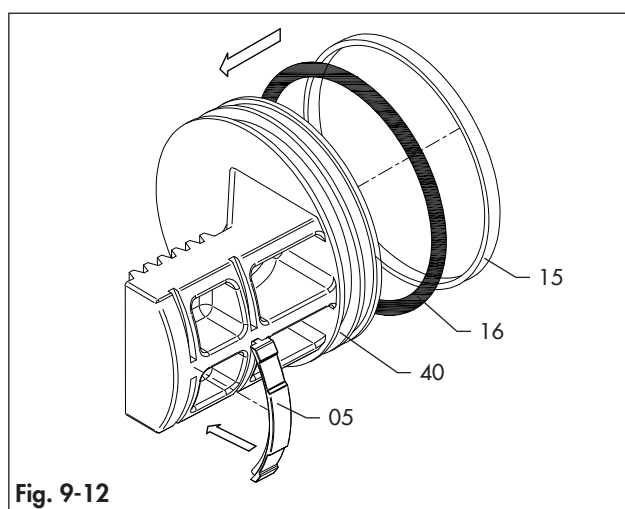

Fig. 9-12

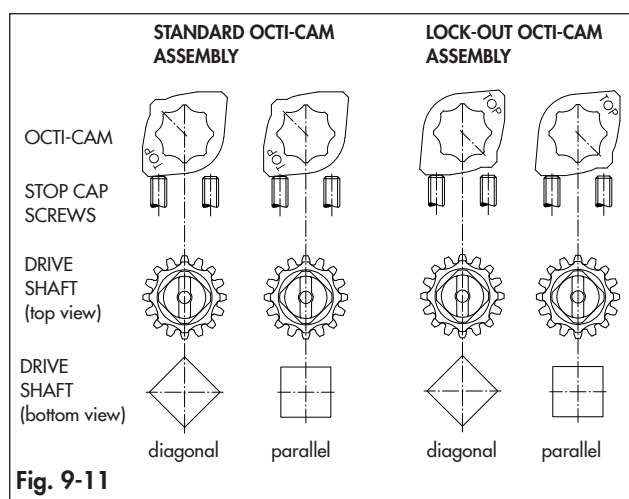

Fig. 9-11

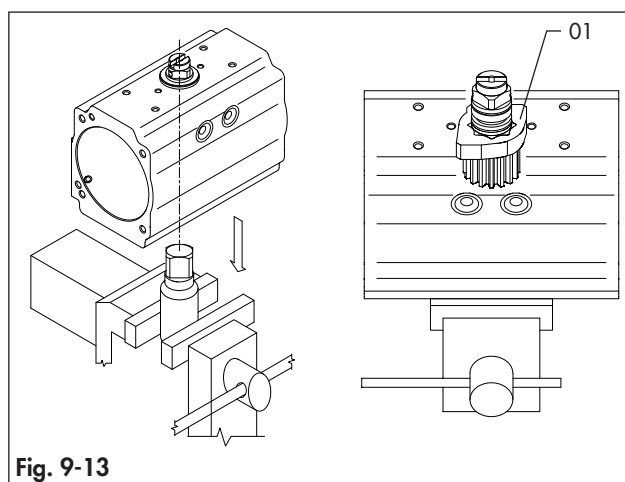

Fig. 9-13

9.5.2 Pistons reassembly

Refer to Fig. 9-1, Fig 9-12, Fig 9-13 and Fig 9-14.

Proceed as follows to reassemble standard SAMSON ROTACTOR RP 3171 actuator pistons with a 90° angle of rotation and clockwise to close. Refer to the technical data sheet T 8325 in case of actuators with different function/rotation.

- Lubricate and place onto the pistons (40) the o-rings (16), piston backs (05) and the head bearings (15).

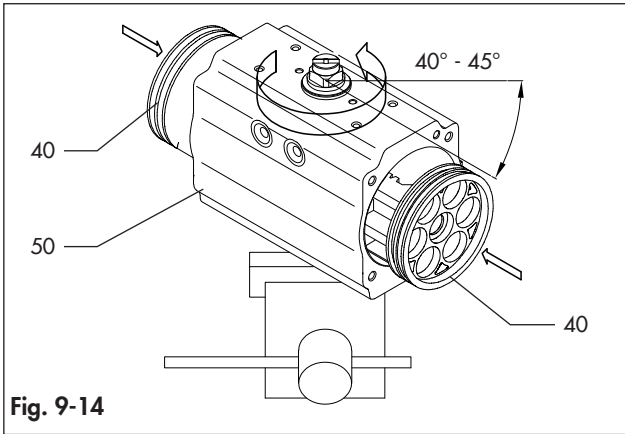

Fig. 9-14

- With pistons completely closed (0° position) as per Fig. 9-15, referring to the axis of the body, the rotation obtained must be:
 - about over 0° up to 5°, for models AT051U to AT801U
 - strictly about over 0° up to 0.5° for model AT045U.
- With pistons completely closed (0° position) as per Fig. 9-15 the dimension "A" must be the same on both sides

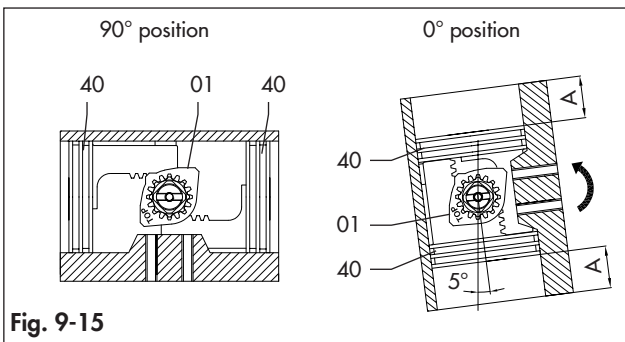

Fig. 9-15

9.5.3 End caps reassembly

Assemble one end cap (30/30R) at a time.

- In case of actuator with extra travel stop adjustment:
 - fasten the stop screws (221G/222G) into the end caps (30) aligning the head of the screw to the end cap surface as shown in Fig. 9-16.
 - lubricate and place the o-rings (11R),
 - place the washer (03R) and fasten partially the nuts (04R).
- ➔ Refer to the data sheet [T 8325] for extra travel stop adjustment components.

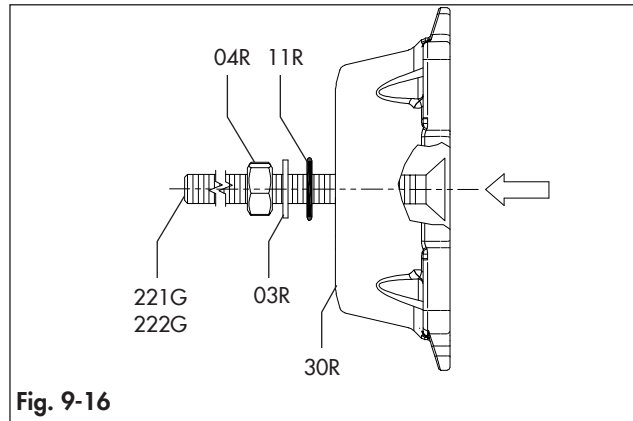

Fig. 9-16

- Place the end caps o-ring (14) into the groove as shown in Fig. 9-17 making sure that the o-ring is stable in its housing.
- Lubricate again the internal surface of the body (50).
- Place the actuator in vertical position.
- In case of spring return actuator, place the correct quantity of spring cartridges in the correct position as indicated in Table 9-4, Table 9-5, Fig. 9-18 and Fig. 9-19 depending on the actuator model.

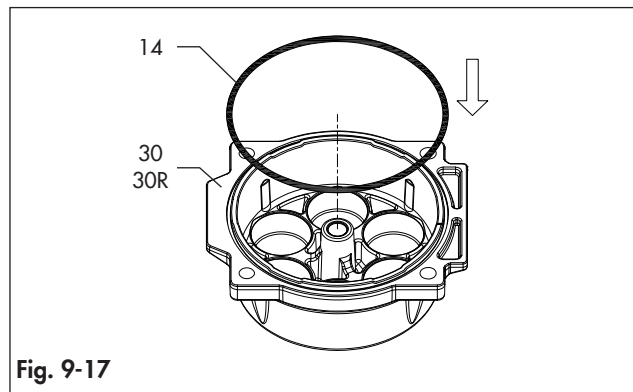

Fig. 9-17

Table 9-4

SPRING TYPE FOR MODELS AT045U		
Spring set	Side B	Side A
S1-1	1 (green)	1 (green)
S1-2	1 (green)	2 (red)
S2-2	2 (red)	2 (red)
S2-3	2 (red)	3 (black)
S3-3	3 (black)	3 (black)

Table 9-5

SPRING TYPE FOR MODELS AT051U				
Spring set	Side B		Side A	
	Internal	External	Internal	External
S1	1 (green)	/	/	2 (black)
S2	/	2 (black)	/	2 (black)
S3	/	2 (black)	/	3 (red)

S4	/	3 (red)	/	3 (red)
S5	/	3 (red)	1 (green)	2 (black)
S6	1 (green)	2 (black)	1 (green)	2 (black)
S7	1 (green)	2 (black)	1 (green)	3 (red)
S8	1 (green)	3 (red)	1 (green)	3 (red)

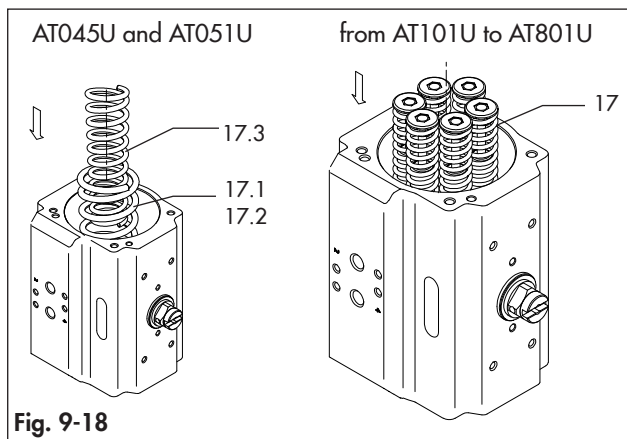

Fig. 9-18

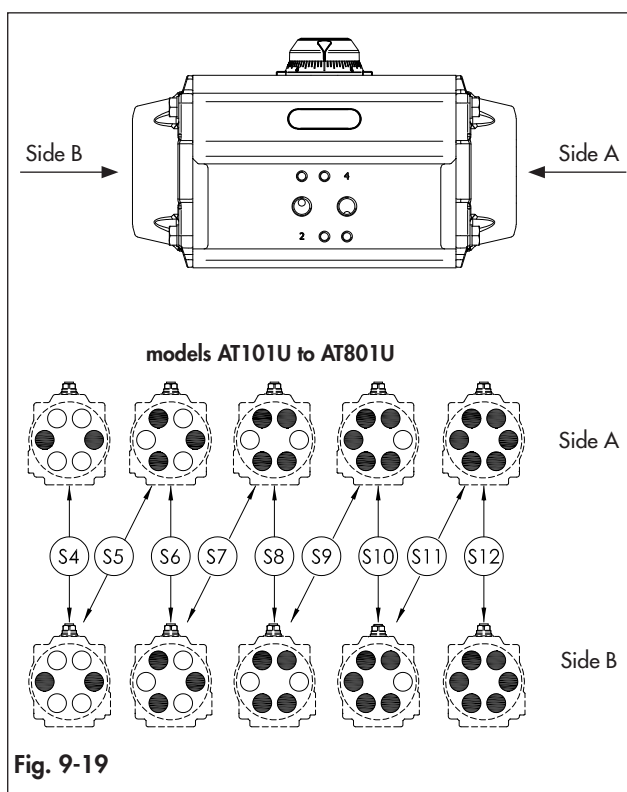

Fig. 9-19

- Place the end cap (30/30R).
- Fix the end cap (30/30R) fastening partially the cap screws (13) 1 turn at a time following the sequence indicated in Fig 9-21.

NOTICE

Risk of components damage due to incorrect assembly.
During reassembling the end caps can be damaged due to uneven force generated by compressed springs.

- ➔ Assemble the end caps as shown in Fig. 9-20 keeping a constant distance ($A = B$) between the actuator body and the end cap interface.
- ➔ Observe the specified sequence shown in Fig. 9-21.

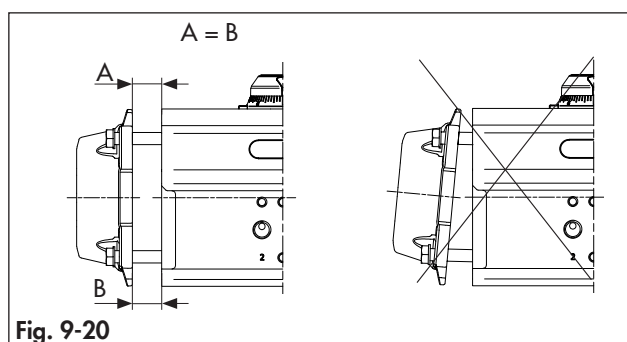

Fig. 9-20

- Complete the fastening of the cap screws (13) tightening 1 turn at a time for each screw in the sequence shown in Fig. 9-21.
- ➔ Refer to the section 15.2 'Tightening torques'. (Table 15.1)

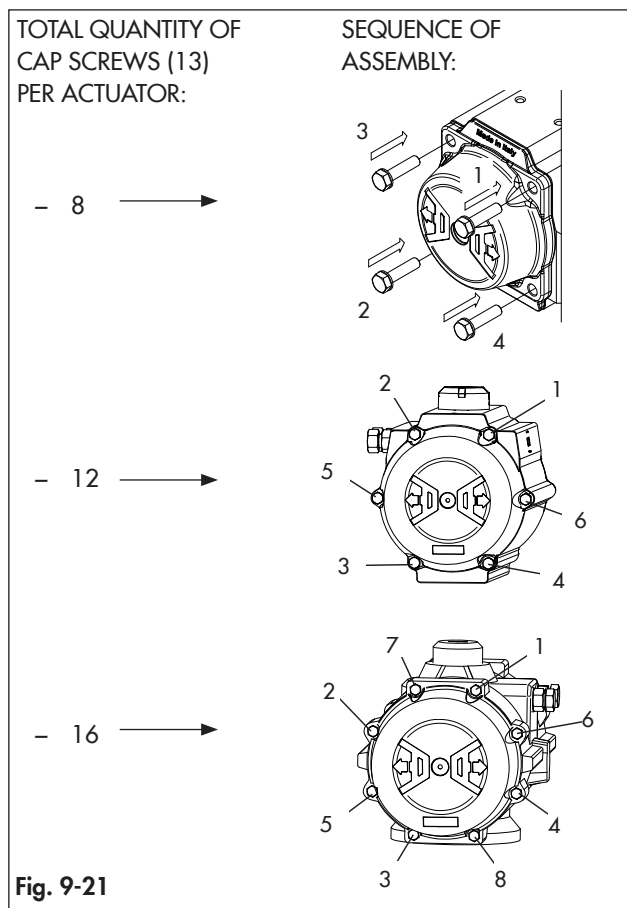

Fig. 9-21

9.5.4 Position indicator reassembly

Refer to Fig. 9-1, Fig. 9-22 and Fig. 9-23.

- Fix the graduated ring (19.0) into the body, if any.
- Place the indicator (19/19.1) referring to the correct actuator position.

- Fasten the indicator screw (39), if any. (Fig. 9-23)

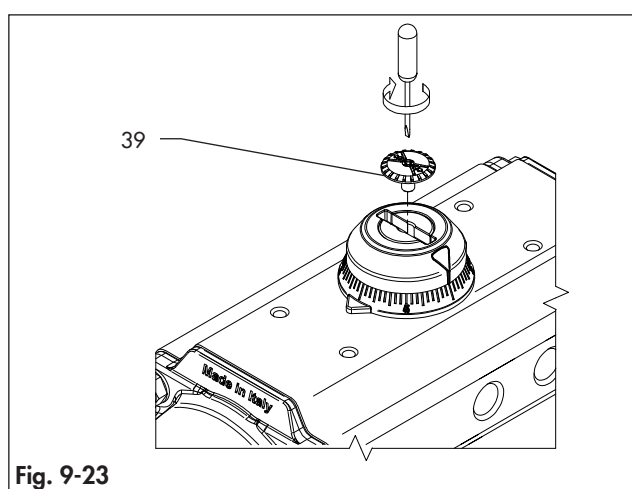
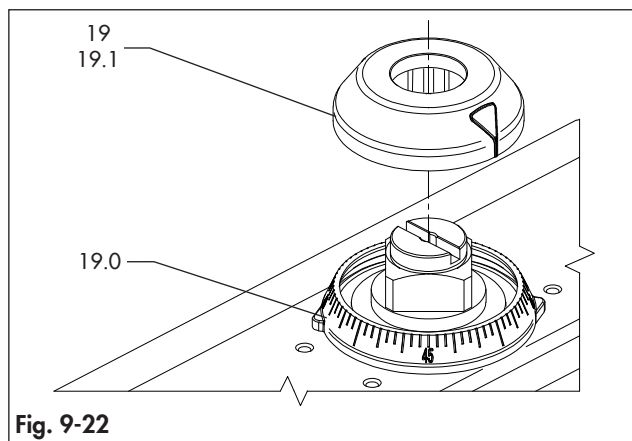

9.5.5 Stop cap screws reassembly

Refer to Fig. 9-1 and Fig. 9-24.

- Insert onto both stop screws (02), the nut (04), the washer (03) and the o-ring (11).
- Place the stop cap screws (02) into the body (50).

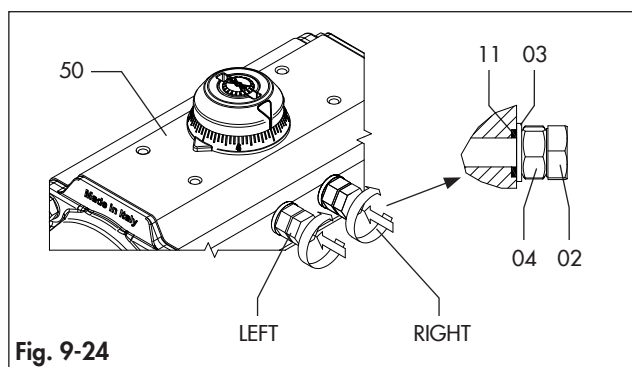

9.5.6 Stroke adjustment

Refer to Fig. 9-1 and Fig. 9-24.

Close position

- With the actuator in close position (0° position) referring to Fig. 9-15 for pistons position, screw or unscrew the right stop screw (02) 1 turn at a time until the desired stop position is achieved. In case of spring return actuator, a pneumatic supply may be necessary.

⚠ WARNING

Risk of personal injury due to pneumatic supply.

Stop screws are not still properly tightened. Any pneumatic supply can eject the stop screws out from the actuator body.

- ➔ Before starting pressurizing the actuator, make sure the stop screws are screwed at least for a length equal to the screw diameter. Refer to the 'Tightening torques' (Table 15.3) for the screw dimensions.

- Holding the stop screw (02) in position, tighten the stop adjustment nut (04) to lock the stop screw (02).

- ➔ Refer to the section 15.2 'Tightening torques'. (Table 15.3)

Open position

- With the actuator in open position (90° position), screw or unscrew the left stop screw (02) 1 turn at a time until the desired stop position is achieved.

- Holding the stop screw (02) in position, tighten the stop adjustment nut (04) to lock the stop screw (02).

- ➔ Refer to the section 15.2 'Tightening torques'. (Table 15.3)

- Regulate the extra travel stop adjustment, if any.

- ➔ Refer to the data sheet [T 8325] for extra travel stop adjustment.

9.5.7 Mounting the actuator over the valve

Refer to the section 5.3 'Mounting the actuator over the valve'.

10 Decommissioning

The work described in this section is only to be performed by fully trained and qualified personnel.

⚠ DANGER

Risk of bursting due to incorrect opening of pressurized equipment or components.

Pneumatic actuators are pressure equipment that may burst when handled incorrectly. Flying projectile fragments or components can cause serious injury or even death.

→ Before starting any work on the actuator disconnect all pneumatic / hydraulic / electrical supplies and discharge the pressure from the actuator.

⚠ WARNING

Risk of personal injury due to preloaded and compressed springs.

End caps are under tension due to compressed springs. Furthermore incorrect spring cartridges disassembly could result in serious injury.

→ Before starting any work on the actuator disconnect all pneumatic / hydraulic / electrical supplies and discharge the pressure from the actuator.

→ Make sure that the actuator is in the closed position (0°).

⚠ WARNING

Risk of personal injury during actuator air exhaust.

In case of pneumatic version the actuator is operated with air. As a result, air is exhausted during operation.

→ Wear eye and hearing protection when working near the actuator.

⚠ WARNING

Crush hazard arising from moving parts.

The actuator and the valve assembly contains moving parts, which can injure hands or fingers.

→ Do not touch or insert hands or finger into moving parts.

→ Before starting any work on the actuator disconnect all pneumatic / hydraulic / electrical supplies and discharge the pressure from the actuator.

→ Do not impede the movement of the pinion and the pistons by inserting objects into the actuator.

ⓘ NOTICE

Risk of actuator damage due to excessively high or low tightening torques.

Follow the specified torques to tighten actuator components (bolts and nuts). Excessive tightening torques lead to parts wearing out quicker. Parts that are not tightened enough may loosen.

→ Refer to section 15.2 'Tightening torques'.

To decommission the actuator for service work or before removing it from the valve, proceed as follows:

1. Put the valve and its accessories out of operation in a safe position. Refer to the documentation available from the valve manufacturer.
2. Disconnect the pneumatic/electrical supply to depressurize the actuator. In case of spring return actuator, make sure the actuator reaches the FAIL position once depressurized.

11 Removal

The work described in this section is only to be performed by fully trained and qualified personnel only.

Before removing from the valve, make sure the actuator is put out of operation. Refer to section 10 'Decommissioning'.

⚠ DANGER

Risk of bursting due to incorrect opening of pressurized equipment or components.

Pneumatic actuators are pressure equipment that may burst when handled incorrectly. Flying projectile fragments or components can cause serious injury or even death. Before working on the actuator:

- ➔ Before starting any work on the actuator disconnect all pneumatic / hydraulic / electrical supplies and discharge the pressure from the actuator.

⚠ WARNING

Risk of personal injury during actuator air exhaust.

In case of pneumatic version the actuator is operated with air. As a result, air is exhausted during operation.

- ➔ Wear eye and hearing protection when working near the actuator.

⚠ WARNING

Risk of personal injury due to preloaded and compressed springs.

End caps are under tension due to compressed springs.

Furthermore incorrect spring cartridges disassembly could result in serious injury.

- ➔ Before starting any work on the actuator disconnect all pneumatic / hydraulic / electrical supplies and discharge the pressure from the actuator.
- ➔ Make sure that the actuator is in the closed position (0°).

⚠ WARNING

Crush hazard arising from moving parts.

The actuator and the valve assembly contains moving parts, which can injure hands or fingers.

- ➔ Do not touch or insert hands or finger into moving parts.
- ➔ Before starting any work on the actuator disconnect all pneumatic / hydraulic / electrical supplies and discharge the pressure from the actuator.
- ➔ Do not impede the movement of the pinion and the pistons by inserting objects into the actuator.

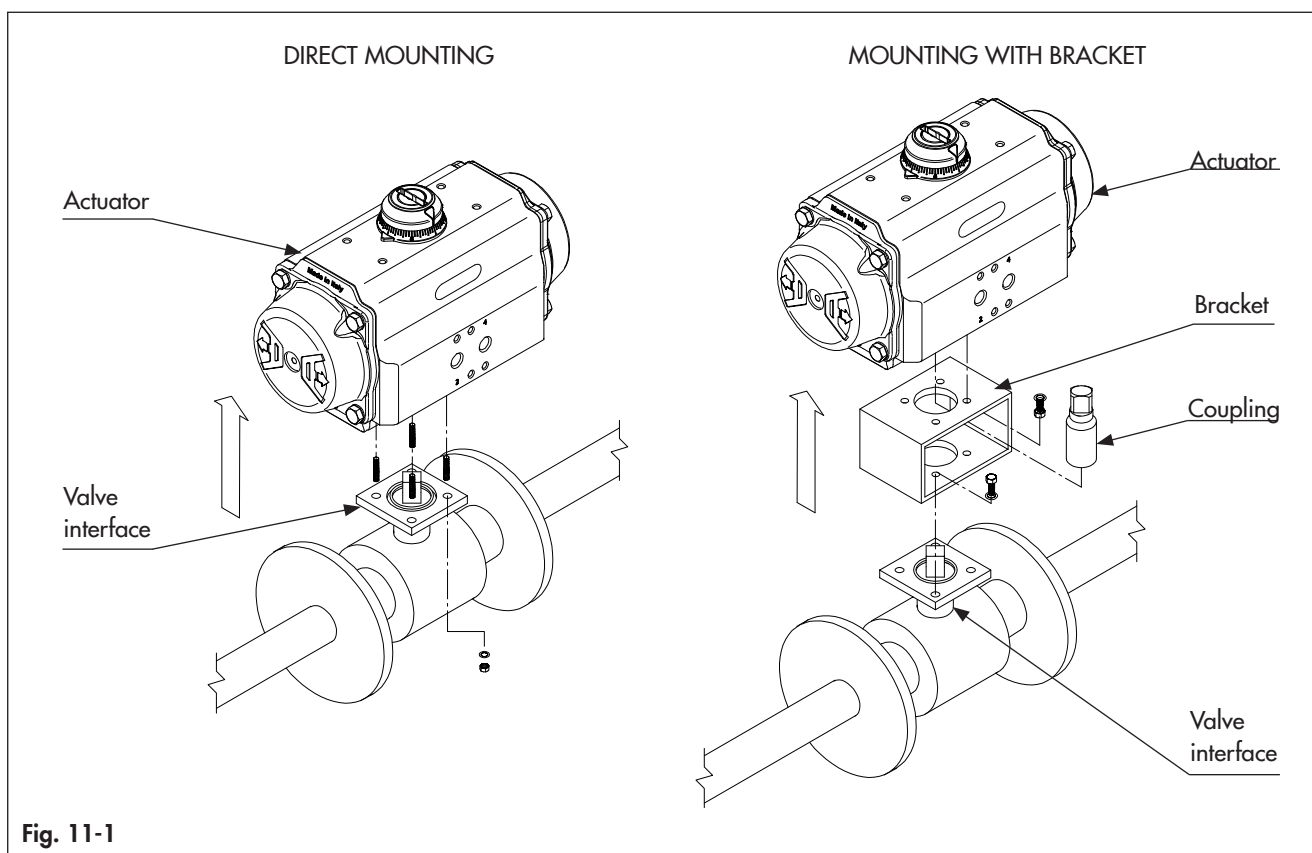

Fig. 11-1

Removal

Proceed as follows to remove the actuator from the valve referring to Fig. 11-1, making sure to not expose the plant to any risk:

1. Disconnect any electrical/pneumatic/hydraulic power supply from the actuators and make sure the actuator itself is depressurized.
2. Disconnect all electrical wirings of the control or signal devices, if any.
→ Refer to the control or signal devices documentation for safe disassembly.
3. Remove the bolts and nuts from the valve flange and remove the actuator from the valve. Refer to the ISO 5211 for correct tightening torques.
4. Remove the coupling.
5. Remove the bracket from the actuator, if any.
6. Remove the control or signal devices, if any.
→ Refer to the control or signal devices documentation for safe disassembly.

12 Repairs

If the actuator does not function properly according to how it was originally sized or does not function at all, it is defective and must be repaired or replaced.

⚠ NOTICE

Risk of actuator damage due to incorrect repair work.

- *Do not perform any repair work on your own.*
 - *Contact SAMSON after-sales service
(samson@samsongroup.com) for repair work.*
-

13 Disposal

At the end of their life cycle SAMSON actuators can be completely disassembled and disposed sorting the components by the different materials.

→ Observe local, national and international refuse regulations.

All materials have been selected in order to ensure minimal environmental impact, health and safety of personnel during their installation and maintenance, provided that, during use, they are not contaminated by hazardous substances.

Oil, grease and electric components may require special treatment before disposal.

→ Contact waste management companies and/or local authorities.

⚠ WARNING

Risk of personal injury due to preloaded and compressed springs.

End caps are under tension due to compressed springs.

Furthermore incorrect spring cartridges disassembly could result in serious injury.

→ *Before starting any work on the actuator disconnect all pneumatic / hydraulic / electrical supplies and discharge the pressure from the actuator.*

→ *Make sure that the actuator is in the closed position (0°).*

→ *Do not disassemble individual spring cartridges.*

→ *For spring cartridges service contact SAMSON.*

The disposal is to be performed by fully trained and qualified personnel only.

- Decommission and remove the actuator (refer to section 10 'Decomissioning' and section 11 'Removal').
- Create a large area around the actuator in order to work in safe conditions without obstacles that can interfere with the disposal operation.
- Dismantle the actuator sorting the components by the different materials.

14 Certificates

The following certificates and documents are available from SAMSON:

- EU Declaration of Conformity (page 14-2),
- ATEX Directive 2014/34/EU,
- SIL Certification,
- Machine Directive 2006/42/EC,
- DNV Type Approval
- IP67 and IP68 Degree of protection,
- TR CU 010/2011,
- TR CU 012/2011,
- UKCA Certification.



AIR TORQUE

AIR TORQUE S.p.A.
 via dei Livelli di Sopra, N° 8/11
 24060 Costa di Mezzate (Bg) Italy
 Tel.: +39 035 682299
 Fax: +39 035 687791
 E-mail: info@airtorque.it



Doc. n° ECDDUE

Issued: 01/2022 - Pag: 1/1

EU / UK DECLARATION OF CONFORMITY

In accordance with
Machinery Directive 2006/42/EC and U.K. Reg. S.I. 2008 No.1597 (as amended)
Atex Directive 2014/34/EU and U.K. Reg. S.I. 2016 No.1107 (as amended)
Pressure Equipment Directive (PED) 2014/68/EU and U.K. Reg. S.I. 2016 No.1105 (as amended)
 We: AIR TORQUE S.p.A. Via dei Livelli di Sopra, 8/11 - 24060 Costa di Mezzate (BG) Italy declare:

Machinery Directive 2006/42/EC (Art. 13) and U.K. Reg. S.I. 2008 No.1597 (as amended)

Declaration of incorporation of the partly completed machine (Annex II part B)

With reference to the Machinery Directive 2006/42/EC (Art. 2 point g) and U.K. Reg. S.I. 2008 No.1597 (as amended) (Part 2 point 6), the pneumatic actuators produced by Air Torque Spa listed below can be classified as "Partly completed machine". We hereby declare that the products specified below meet the basic health and safety requirements.

Before the actuators are put into operation, the machine into which the actuators will be installed, shall fulfill with the requirements of the Directive 2006/42/EC and U.K. Reg. S.I. 2008 No.1597 (as amended).

The essential requirements are applied in compliance with the following points of the Machinery Directive and U.K. Regulation:

1.1.3, 1.1.5, 1.2.1, 1.3.2, 1.3.4, 1.3.7, 1.3.8, 1.3.8.1, 1.4.1, 1.4.2.1, 1.5.1, 1.5.2, 1.5.3, 1.5.4, 1.5.7, 1.5.8, 1.6.1, 1.7.2, 1.7.3, 1.7.4

Description of the product line: Pneumatic actuators AIR TORQUE 4thG Upgrade Series

Type: Double acting "D" and Spring return "S".

Actuator models: AT-045U S/D, AT051U S/D ÷ AT1001U S/D (including the product variations).

Serial number: Each Air Torque actuator has a serial number for traceability.

For the use, installation and maintenance of the actuators described above, see the related manual instructions.

Atex Directive 2014/34/EU and U.K. Reg. S.I. 2016 No.1107 (as amended)

The pneumatic actuators produced by Air Torque Spa (Series ATxxxxU) are designed, produced and classified according to Atex Directive 2014/34/EU and U.K. Reg. S.I. 2016 No.1107 (as amended), (see actuator label and safety instructions); their use in areas with potentially explosive atmosphere is subject to the classification indicated on the label and in compliance with the relevant ATEX safety instructions.

Product marking (Series ATxxxxU)

Execution LLT2, LLT, ST

Execution HT

Group IIB (Gas)
 Group IIIC (Dust)

UK CA CE II 2 G Ex h IIB T6 ... T5 Gb X
 UK CA CE II 2 D Ex h IIIC T85°C ... T95°C Db X

UK CA CE II 2 G Ex h IIB T6 ... T3 Gb X
 UK CA CE II 2 D Ex h IIIC T85°C ... T165°C Db X

Group IIC (Gas)
 Group IIIC (Dust)

UK CA CE II 2 G Ex h IIC T6 ... T5 Gb X
 UK CA CE II 2 D Ex h IIIC T85°C ... T95°C Db X

UK CA CE II 2 G Ex h IIC T6 ... T3 Gb X
 UK CA CE II 2 D Ex h IIIC T85°C ... T165°C Db X

Compliance has been verified on the basis of the requirements of the standards or normative documents indicated below:

EN 1127-1:2019

EN 15714-3:2009

EN 80079-36:2016

EN 80079-37:2016

Technical file: **ATX19AT-RP**
 Technical file: **UKX21AT-RP**

Notified body (EU): **INERIS (0080)**
 Approved body (UK): **EUROFINS E&E CML Limited (2503)**

Pressure equipment directive (PED) 2014/68/EU and U.K. Reg. S.I. 2016 No.1105 (as amended)

The pneumatic actuators produced by Air Torque Spa (Series ATxxxxU) are designed according to the criteria of Article 1 / Schedule 1 paragraph 2. j) ii) and they are suitable to be used with **non dangerous** fluids of the Group 2; therefore, according to directive 2014/68/EU and U.K. Reg. S.I. 2016 No.1105, they are not to be considered pressure equipments .

Signed:

Name: *A. Marinoni*

Position: Managing Director I Design and Quality Manager

AIR TORQUE S.p.A. - Italy

15 Annex

15.1 Tools

15.1.1 Tools list

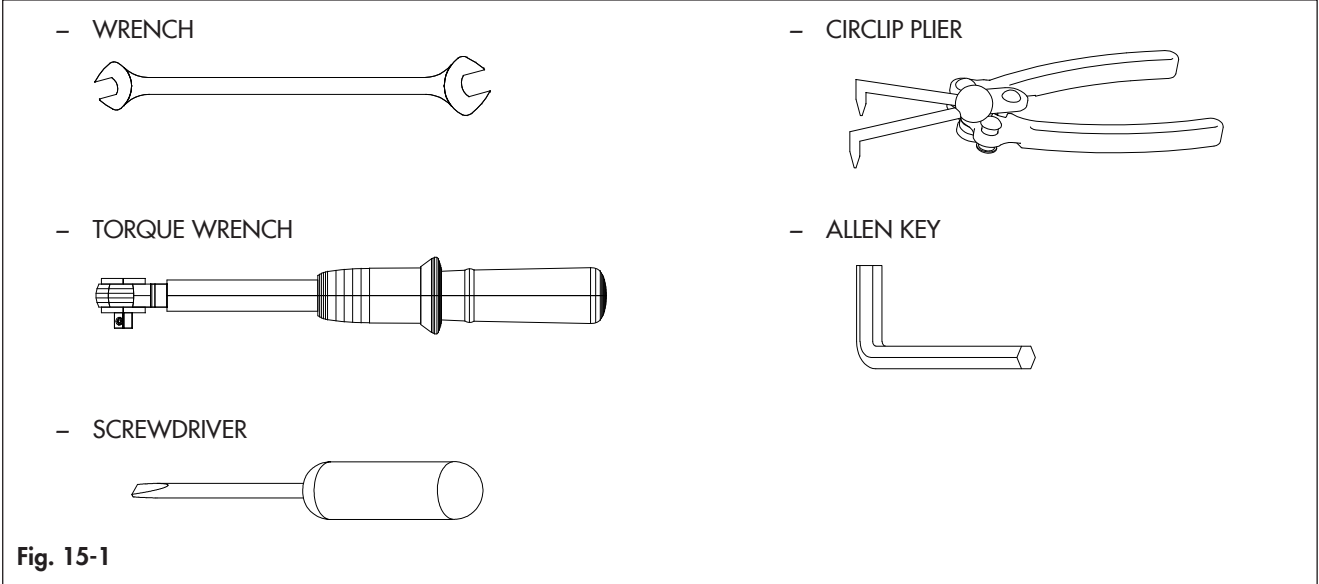

Fig. 15-1

15.1.2 Tools dimensions

- Stop screws (02) and nuts (04); end cap screws (13).

ACTUATOR MODEL	Ch 1 (mm)	Ch 2 (mm)
AT045U	/	8
AT051U	10	8
AT101U	10	10
AT201U	13	10
AT251U	13	10
AT301U	17	13
AT351U	19	13
AT401U	19	17
AT451U	22	17
AT501U	22	19
AT551U	24	19
AT601U	30	22
AT651U	30	24
AT701U	36	22
AT751U	46	24
AT801U	46	24

Fig. 15-2

- Extra travel stop adjustment screws tools (50% and 100% adjustment)

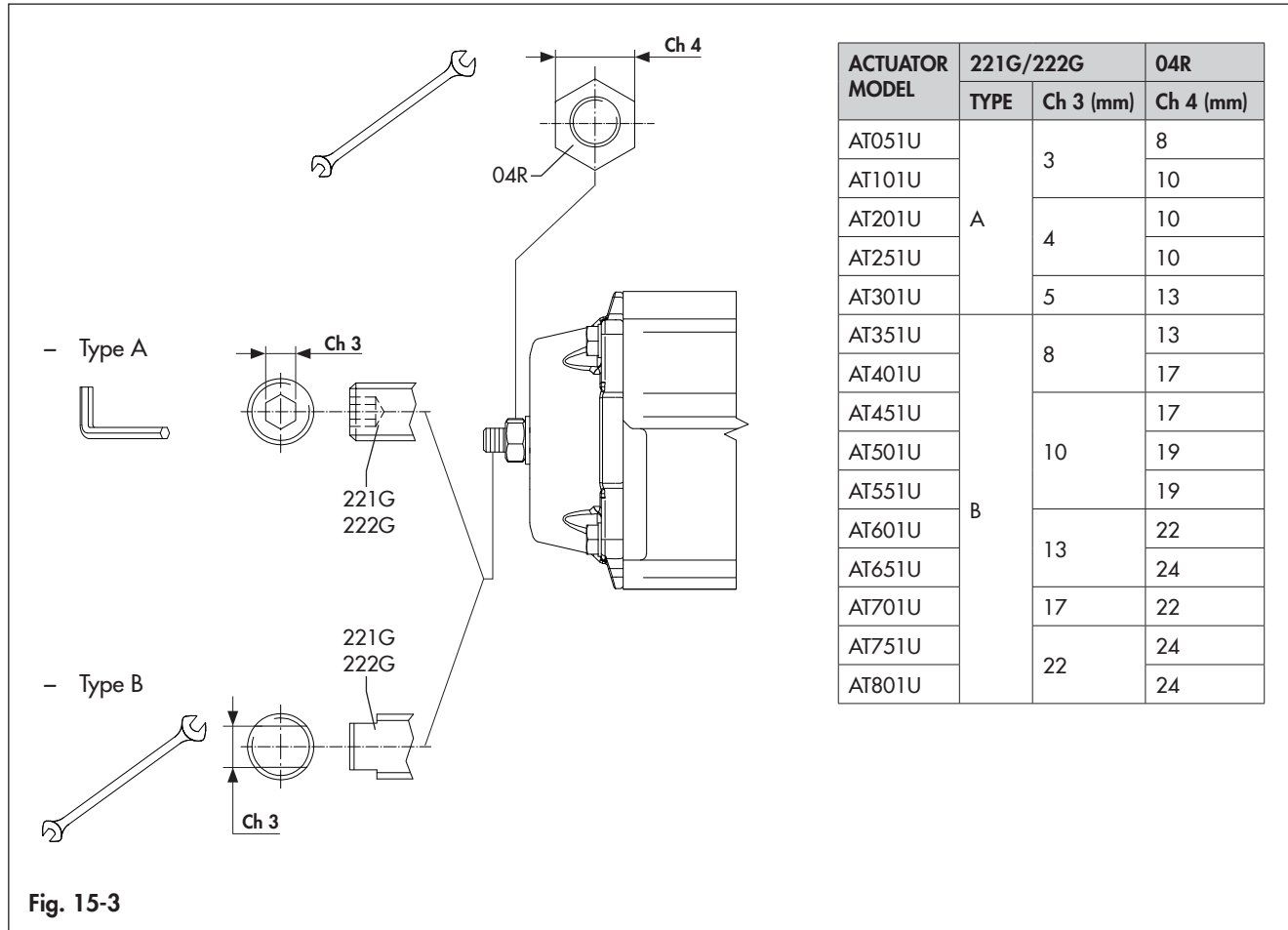

15.2 Tightening torques

- All the tightening torques are intended in Nm.
- Tightening torque tolerance: $\pm 10\%$.
- The tightening torques are based on a friction coefficient of 0.12 with a lubricated fixing elements (bolts or nuts) threads.
- After long operating times or use at temperatures above 80°C , the breakaway torque may be significantly higher.

Table 15-1: End cap screws (13)

ACTUATOR MODEL	THREAD	TIGHTENING TORQUE (Nm)
AT045U	M5	4 ÷ 5
AT051U		
AT101U	M6	7 ÷ 8
AT201U		
AT251U		
AT301U	M8	18 ÷ 20
AT351U		
AT401U	M10	34 ÷ 36
AT451U		
AT501U	M12	60 ÷ 64
AT551U		
AT601U	M14	96 ÷ 102
AT651U	M16	150 ÷ 160
AT701U	M14	96 ÷ 102
AT751U	M16	150 ÷ 160
AT801U		

Table 15-2: Extra travel stop adjustment nuts (04R)

ACTUATOR MODEL	THREAD	TIGHTENING TORQUE (Nm)
AT051U	M6	8 ÷ 9
AT101U		
AT201U	M8	18 ÷ 20
AT251U		
AT301U	M10	34 ÷ 36
AT351U	M12	60 ÷ 64
AT401U		
AT451U	M14	96 ÷ 102
AT501U		
AT551U	M16	80 ÷ 86
AT601U	M20	160 ÷ 170
AT651U		
AT701U	M24	270 ÷ 290
AT751U	M30	540 ÷ 570
AT801U		

Table 15-3: Stop screws nuts (04)

ACTUATOR MODEL	THREAD	TIGHTENING TORQUE (Nm)
AT051U	M6	8 ÷ 9
AT101U		
AT201U	M8	18 ÷ 20
AT251U		
AT301U	M10	34 ÷ 36
AT351U	M12	60 ÷ 64
AT401U		
AT451U	M14	96 ÷ 102
AT501U		
AT551U	M16	150 ÷ 160
AT601U	M20	290 ÷ 310
AT651U		
AT701U	M24	235 ÷ 250
AT751U	M30	470 ÷ 500
AT801U		

Table 15-4: Pressure connection

ACTUATOR MODEL	THREAD	TIGHTENING TORQUE (Nm)
AT045U	M5	4 ÷ 5
AT051U		
AT101U		
AT201U		
AT251U		
AT301U		
AT351U		
AT401U		
AT451U		
AT501U		
AT551U		
AT601U	M6	8 ÷ 9
AT651U		
AT701U		
AT751U		
AT801U		

Table 15-5: Ancillary attachments

SIZE ¹	THREAD	TIGHTENING TORQUE (Nm)
AA 0	M5	4 ÷ 5
AA 1		
AA 2		
AA 3		
AA 4		
AA 5	M6	8 ÷ 9

NOTE:

1. Refer to section 2.1 'Actuator nameplate sample'.

15.3 Lubricants

The SAMSON ROTACTOR RP 3171 actuators are factory lubricated for the life of the actuator in normal working conditions.

- ➔ Refer to the data sheet [T 8325] for lubricant type in relation to the different working temperature ranges.

16 Rubber products storage instructions

16.1 Overview

The information in this document applies to all the products and/or parts supplied by SAMSON which include rubber components. Rubber products and components are affected by irreversible changes of material properties due to a natural ageing effect even if properly stored. Therefore in case of long period of storage before use, make sure to store properly the rubber products to minimize ageing deleterious effects.

16.2 Storage conditions

In order to minimize unwanted degradation of rubber products/components, it is recommended to keep stored products in their original packaging. Moreover according to ISO 2230 observe the following conditions that may influence the storage:

Temperature

The preferred storage temperature should be below 25°C (77°F) and the parts/products should be stored far away from direct heat sources. The minimum storage temperature in relation to the components operating temperature range is indicated in Table 1.

Table 16-1:

Operating temperature range	Minimum storage temperature
ST	-40°C (-40°F)
HT	-15°C (+5°F)
LLT2	-60°C (-76°F)

However if the storage temperature is equal or below 15°C (+59°F), the rubber will stiffen and become susceptible to distortion if not handled carefully. Before the product is put into service the storage temperature should be raised to approximately 30°C (+86°F).

i Note

Storage at a 10°C (18°F) higher temperature will reduce the maximum storage life by about 50% and storage at a 10°C (18°F) lower temperature will increase the maximum storage life by about 100%.

Humidity

Make sure that the relative humidity of the atmosphere in the storage area is under 70%, especially in case of rubber products not stored in moisture proof sealed bags. Avoid condensation in the storage rooms.

Light

The rubber products must be protected from light sources, especially from direct sunlight or intense artificial light having a high UV content that could damage the products. It is preferable to store in dark areas without any sunlight exposure.

Radiation

In order to avoid deterioration protect the rubber products from all sources of ionizing radiation.

Ozone

Provided that ozone is deleterious to rubber products, storage rooms should not contain any electrical devices that can generate ozone, such as mercury vapor lamps or high-voltage electrical equipment giving rise to electric sparks or silent electrical discharges.

Deformation

Rubber seals should be stored free from superimposed tensions or compressive stresses or other causes of deformation. Cracking or permanent deformation may occur. Products have to be stored in their original SAMSON packaging.

Contact with liquid or semi-liquid materials

During the storage the rubber components shall not be allowed to come in contact with any liquid or semi-solid materials (for example, gasoline, greases, acids, disinfectants, and cleaning fluids) or their vapours, different from the SAMSON suitable lubricants.

Contact with metals

Rubber seals shall not be stored in contact with certain metals and their alloys (in particular, copper, manganese, and iron) that have deleterious effects on elastomers. Products have to be stored in their original SAMSON packaging.

Rotation of stock

Products should be taken from the stores taking care to perform a strict rotation so that the remaining products in store are those of most recent manufacture or delivery. Indeed SAMSON storage management performs a complete rotation of stock within 12 months for rubber components.

16.3 Storage life

The storage life is the maximum period of time that a rubber product, appropriately packaged, may be stored from the manufacturing date. After this time the product is to be considered as unserviceable for the purposes for which it was designed. An extension storage period is applicable only to spare parts (and any other kit with rubber products) properly stored into the original SAMSON packaging. In this case the rubber products should be inspected and tested before the storage life expiry (refer to Table 2) as specified in the standard ISO 2230. For SAMSON products and spare parts, the manufacturing date can be identified:

- by the date printed on packaging label or on the actuator nameplate (Fig. 02, Fig. 03 and Fig. 04),
- by the Product Serial Number (only for complete actuators). (Fig. 03 and Fig. 04)

Referring to what described above and considering the different rubber materials properties and according to ISO 2230, the suggested maximum storage life of rubber products is indicated in Table 2.

Rubber products storage life is not an exact science since it is significantly affected by storage and handling conditions.

Rubber products storage instructions

However they should preferably be used within a period not longer than 24 months.

Table 16-2:

Classification of Group	Rubbers Chemical Name and Abbreviation	Maximum storage life	Extension storage periods
A	Butadiene rubber (BR) Isoprene rubber, natural (NR) Isoprene rubber, synthetic (IR) Styrene-butadiene rubber (SBR) Polyester urethane rubber (AU/EU)	5 years	2 years
B	Acrylonitrile-butadiene rubber (NBR) Carboxylic- acrylonitrile-butadiene rubber (XNBR) Hydrogenated NBR rubber (HNBR) Copolymer of ethylacrylate (or other acrylates) (ACM) Chloroprene rubber (CR) Isobutene-isoprene-rubber (IIR)	7 years	3 years
C	Ethylene-Propylene copolymer (EPM) Ethylene-Propylene Diene Monomer (EPDM) Perfluoroalkyl or Perfluoroalkoxy (FKM) Silicone and Fluorosilicone rubbers (VMQ, FMQ, ecc.)	10 years	5 years

1. Repackaging

If SAMSON products are removed from storage for inspection or testing and re-stored for a further storage period, they should be repackaged according to this document or with the same original packaging.

2. Standard SAMSON packaging

Spare parts and kits with rubber components

If not otherwise specified, the SAMSON spare parts and kits with rubber components are packaged in polyethylene transparent bags material not UV resistant, packed in carton or wood boxes as shown in Fig. 01.



Kit packages are identified with external box labels (Fig .02).

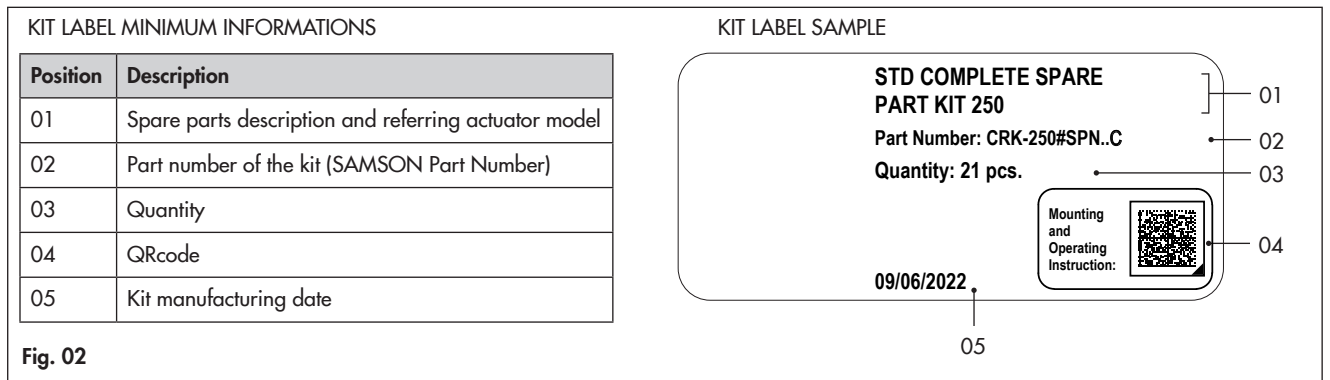

Actuators

The SAMSON Rack and pinion and actuators are packaged in carton boxes and carton or wooded cases.

Store all the SAMSON products according to the related IMAT maintenance instruction manuals in order to guarantee the correct product functions and performance.

Each actuator is identified by an external box label (only for rack and pinion actuators) and a label/nameplate placed directly over the actuator. (Fig. 03 and Fig. 04)

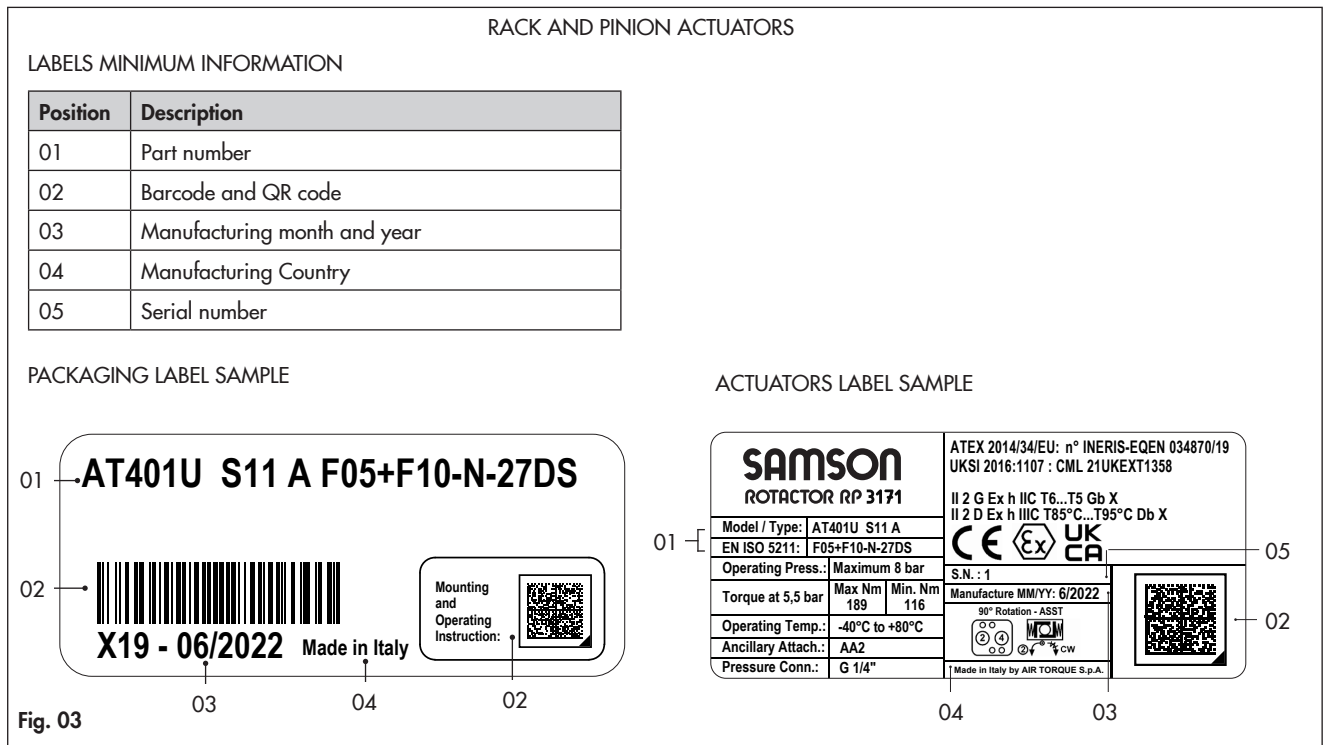



SAMSON AKTIENGESELLSCHAFT
Weismüllerstraße 3 · 60314 Frankfurt am Main, Germany
Phone: +49 69 4009-0 · Fax: +49 69 4009-1507
samson@samsongroup.com · www.samsongroup.com