

# MOUNTING AND OPERATING INSTRUCTIONS

SAMSON

## EB 8004-GR EN

Translation of original instructions



SMS MG-1 Pneumatic Control Valve: Type 251GR Valve with Type 3271 Actuator

### **Type 251GR Valve - ANSI version**

In combination with an actuator,  
e.g. a Type 3271 or Type 3277 Pneumatic Actuator

Edition November 2024

CE

## Note on these mounting and operating instructions

These mounting and operating instructions assist you in mounting and operating the device safely. The instructions are binding for handling SAMSON devices. The images shown in these instructions are for illustration purposes only. The actual product may vary.

- For the safe and proper use of these instructions, read them carefully and keep them for later reference.
- If you have any questions about these instructions, contact SAMSON's After-sales Service (aftersaleservice@samsongroup.com).



Documents relating to the device, such as the mounting and operating instructions, are available on our website at [www.samsongroup.com](http://www.samsongroup.com) > **Downloads > Documentation.**

## Definition of signal words

### **DANGER**

*Hazardous situations which, if not avoided, will result in death or serious injury*

### **WARNING**

*Hazardous situations which, if not avoided, could result in death or serious injury*

### **NOTICE**

*Property damage message or malfunction*

### **Note**

*Additional information*

### **Tip**

*Recommended action*

<b>1</b>	<b>Safety instructions and measures</b> .....	<b>1-1</b>
1.1	Notes on possible severe personal injury .....	1-5
1.2	Notes on possible personal injury .....	1-5
1.3	Notes on possible property damage .....	1-8
1.4	Notes on the use of an RFID tag .....	1-9
1.5	Warnings on the device .....	1-9
<b>2</b>	<b>Markings on the device</b> .....	<b>2-1</b>
2.1	Valve nameplate .....	2-1
2.2	Actuator nameplate .....	2-2
2.3	Material identification number .....	2-2
2.4	Label when an adjustable packing is installed .....	2-2
2.5	Optional RFID tag .....	2-3
<b>3</b>	<b>Design and principle of operation</b> .....	<b>3-1</b>
3.1	Actuators .....	3-1
3.2	Fail-safe positions .....	3-6
3.2.1	Fail-safe action "actuator stem extends" (FA) .....	3-6
3.2.2	Fail-safe action "actuator stem retracts" (FE) .....	3-6
3.3	Versions .....	3-6
3.4	Additional fittings .....	3-6
3.5	Valve accessories .....	3-7
3.6	Technical data .....	3-7
<b>4</b>	<b>Shipment and on-site transport</b> .....	<b>4-1</b>
4.1	Accepting the delivered goods .....	4-1
4.2	Removing the packaging from the valve .....	4-1
4.3	Transporting and lifting the valve .....	4-1
4.3.1	Transporting the valve .....	4-2
4.3.2	Lifting the valve .....	4-3
4.4	Storing the valve .....	4-5
<b>5</b>	<b>Installation</b> .....	<b>5-1</b>
5.1	Installation conditions .....	5-1
5.2	Preparation for installation .....	5-2
5.3	Mounting the device .....	5-4

## Contents

5.3.1	Mounting the external anti-rotation fixture.....	5-4
a)	Standard version for nominal size NPS 6 and larger.....	5-4
b)	Special version for nominal sizes NPS 2 to 4.....	5-8
5.3.2	Mounting the actuator onto the valve.....	5-15
a)	Mounting the actuator.....	5-16
b)	Aligning the travel indicator scale.....	5-17
5.4	Installing the valve into the pipeline.....	5-17
5.5	Testing the installed valve.....	5-17
5.5.1	Leakage.....	5-19
5.5.2	Travel motion.....	5-21
5.5.3	Fail-safe position.....	5-22
5.5.4	Pressure test.....	5-22
<b>6</b>	<b>Start-up.....</b>	<b>6-1</b>
<b>7</b>	<b>Operation.....</b>	<b>7-1</b>
7.1	Normal operation.....	7-2
7.2	Manual operation.....	7-2
<b>8</b>	<b>Malfunctions.....</b>	<b>8-1</b>
8.1	Troubleshooting.....	8-1
8.2	Emergency action.....	8-2
<b>9</b>	<b>Servicing and conversion.....</b>	<b>9-1</b>
9.1	Periodic testing.....	9-3
9.2	Preparation for servicing or conversion work.....	9-7
9.3	Mounting the actuator on the valve after service and conversion work.....	9-8
9.4	Service or conversion work.....	9-8
9.4.1	Replacing gaskets in versions with standard bonnet (2) or insulating section (21).....	9-9
a)	Version with clamped-in seat and plug.....	9-9
b)	Version with screwed-in seat and plug.....	9-9
c)	Version with cage and piston.....	9-10



9.4.2	Replacing the packing in versions with standard bonnet (2) or insulating section (21) .....	9-11
a)	Packing centrally fastened with threaded bushing .....	9-11
b)	Version with packing flange (with or without external spring elements) .....	9-12
9.4.3	Replacing the trim in versions with standard bonnet (2) or insulating section (21) .....	9-14
a)	Removing the (clamped-in) seat and plug .....	9-14
b)	Removing the (screwed-in) seat and plug .....	9-15
c)	Removing the cage and piston .....	9-15
d)	Installing the (clamped-in) seat and plug .....	9-16
e)	Installing the (screwed-in) seat and plug ( $\leq$ NPS 6, $\leq$ Class 600) .....	9-17
f)	Installing the cage and piston .....	9-18
9.4.4	Replacing the plug/piston on the plug/piston stem .....	9-20
9.5	Ordering spare parts and operating supplies .....	9-21
<b>10</b>	<b>Decommissioning .....</b>	<b>10-1</b>
<b>11</b>	<b>Removal .....</b>	<b>11-1</b>
11.1	Removing the valve from the pipeline .....	11-2
11.2	Removing the actuator from the valve .....	11-2
<b>12</b>	<b>Repairs .....</b>	<b>12-1</b>
12.1	Returning devices to SAMSON .....	12-1
<b>13</b>	<b>Disposal .....</b>	<b>13-1</b>
<b>14</b>	<b>Certificates .....</b>	<b>14-1</b>
<b>15</b>	<b>Appendix .....</b>	<b>15-1</b>
15.1	Tightening torques, lubricants and tools .....	15-1
15.1.1	Tightening torques .....	15-2
15.1.2	Tools .....	15-5
15.1.3	Lubricants .....	15-6
15.2	Spare parts .....	15-8
15.3	After-sales service .....	15-10



# 1 Safety instructions and measures

## Intended use

The SAMSON Type 251GR Globe Valve (belonging to the SMS Series) in combination with an actuator (e.g. Type 3271 or Type 3277 Pneumatic Actuator) is designed to regulate the flow rate, pressure or temperature of liquids, gases or vapors. The valve with its actuator is designed to operate under exactly defined conditions (e.g. operating pressure, process medium, temperature). Therefore, operators must ensure that the control valve is only used in operating conditions that meet the specifications used for sizing the valve at the ordering stage. In case operators intend to use the control valve in applications or conditions other than those specified, contact SAMSON.

SAMSON does not assume any liability for damage resulting from the failure to use the device for its intended purpose or for damage caused by external forces or any other external factors.

➔ Refer to the technical data and nameplate for limits and fields of application as well as possible uses.

## Reasonably foreseeable misuse

The control valve is not suitable for the following applications:

- Use outside the limits defined during sizing and by the technical data
- Use outside the limits defined by the valve accessories connected to the valve

Furthermore, the following activities do not comply with the intended use:

- Use of non-original spare parts
- Performing service and repair work not described

## Qualifications of operating personnel

The control valve must be mounted, started up, serviced and repaired by fully trained and qualified personnel only; the accepted industry codes and practices must be observed. According to these mounting and operating instructions, trained personnel refers to individuals who are able to judge the work they are assigned to and recognize possible hazards due to their specialized training, their knowledge and experience as well as their knowledge of the applicable standards.

Explosion-protected versions of this device must be operated only by personnel who has undergone special training or instructions or who is authorized to work on explosion-protected devices in hazardous areas.

## Safety instructions and measures

### Personal protective equipment

SAMSON recommends checking the hazards posed by the process medium being used (e.g.

▶ GESTIS (CLP) hazardous substances database). Depending on the process medium and/or the activity, the protective equipment required includes:

- Protective clothing, gloves, eye protection and respiratory protection in applications with hot, cold and/or corrosive media
  - Wear hearing protection when working near the valve
  - Hard hat
  - Safety harness, e.g. when working at height
  - Safety footwear, if applicable ESD (electrostatic discharge) footwear
- ➔ Check with the plant operator for details on further protective equipment.

### Revisions and other modifications

Revisions, conversions or other modifications of the product are not authorized by SAMSON. They are performed at the user's own risk and may lead to safety hazards, for example. Furthermore, the product may no longer meet the requirements for its intended use.

### Safety features

The fail-safe position of the control valve upon air supply or control signal failure depends on the actuator used (see associated actuator documentation). When the valve is combined with a SAMSON Type 3271 or Type 3277 Pneumatic Actuator, the valve moves to a certain fail-safe position (see the 'Design and principle of operation' chapter) upon supply air or control signal failure. The fail-safe action of the actuator is the same as its direction of action and is specified on the nameplate of SAMSON actuators.

### Warning against residual hazards

To avoid personal injury or property damage, plant operators and operating personnel must prevent hazards that could be caused in the control valve by the process medium, the operating pressure, the signal pressure or by moving parts by taking appropriate precautions. Plant operators and operating personnel must observe all hazard statements, warnings and caution notes in these mounting and operating instructions.

Hazards resulting from the special working conditions at the installation site of the valve must be identified in a risk assessment and prevented through the corresponding standard operating procedures drawn up by the operator.

### Responsibilities of the operator

Operators are responsible for proper use and compliance with the safety regulations. Operators are obliged to provide these mounting and operating instructions as well as the referenced documents to the operating personnel and to instruct them in proper operation. Furthermore, operators must ensure that operating personnel or third parties are not exposed to any danger.

Operators are additionally responsible for ensuring that the limits for the product defined in the technical data are observed. This also applies to the start-up and shutdown procedures. Start-up and shutdown procedures fall within the scope of the operator's duties and, as such, are not part of these mounting and operating instructions. SAMSON is unable to make any statements about these procedures since the operative details (e.g. differential pressures and temperatures) vary in each individual case and are only known to the operator.

### Responsibilities of operating personnel

Operating personnel must read and understand these mounting and operating instructions as well as the referenced documents and observe the specified hazard statements, warnings and caution notes. Furthermore, operating personnel must be familiar with the applicable health, safety and accident prevention regulations and comply with them.

### Referenced standards, directives and regulations

The control valves comply with the requirements of the European Pressure Equipment Directive 2014/68/EU and the Machinery Directive 2006/42/EC. Valves with a CE marking have a declaration of conformity which includes information about the applied conformity assessment procedure. The 'Certificates' chapter contains this declaration of conformity.

According to the ignition hazard assessment performed in accordance with Clause 5.2 of ISO 80079-36, the non-electrical control valves do not have their own potential ignition source even in the rare incident of an operating fault. As a result, they do not fall within the scope of Directive 2014/34/EU.

→ For connection to the equipotential bonding system, observe the requirements specified in Clause 6.4 of EN 60079-14 (VDE 0165-1).

### Referenced documents

The following documents apply in addition to these mounting and operating instructions:

- Mounting and operating instructions for the mounted actuator, e.g. ► EB 8310-X for the SAMSON Type 3271 or Type 3277 Pneumatic Actuator
- Mounting and operating instructions for mounted valve accessories (positioner, solenoid valve etc.)

## Safety instructions and measures

- Manual ► H 02: Appropriate Machinery Components for SAMSON Pneumatic Control Valves with a Declaration of Conformity of Final Machinery
- If a device contains a substance listed as a substance of very high concern (SVHC) on the candidate list of the REACH regulation, the document "Additional Information on Your Inquiry/Order" is added to the SAMSON order documents. This document includes the assigned SCIP number, which can be entered into the database on the European Chemicals Agency (ECHA) website (► <https://www.echa.europa.eu/scip-database>) to find out more information on the SVHC contained in the device.

Further information on material compliance at SAMSON is available at

► [www.samsongroup.com](http://www.samsongroup.com) > About SAMSON > Environment, Social & Governance > Material Compliance.

## 1.1 Notes on possible severe personal injury

### DANGER

#### **Risk of bursting in pressure equipment.**

Valves and pipelines are pressure equipment. Excessive pressurization or improper opening can lead to valve components bursting.

- Observe the maximum permissible pressure for valve and plant.
- Before starting any work on pressure-bearing or pressure-retaining parts belonging to the valve assembly, depressurize all plant sections affected as well as the valve.
- Drain the process medium from the plant sections affected as well as from the valve.

## 1.2 Notes on possible personal injury

### WARNING

#### **Risk of burn injuries due to hot or cold components and pipelines.**

Depending on the process medium, valve components and pipelines may get very hot or cold and cause burn injuries.

- Follow the standard operating procedures provided by the plant operator.  
In the event of a potential risk:
  - Allow components and pipelines to cool down or warm up to the ambient temperature.
  - Wear protective clothing and safety gloves.

#### **Risk of hearing loss or deafness due to loud noise.**

The noise emissions depend on the valve version, plant facilities and process medium.

- Follow the standard operating procedures provided by the plant operator.  
In the event of a potential risk:
  - Wear hearing protection when working near the valve.

### **WARNING**

#### **Risk of personal injury due to exhaust air being vented or compressed air escaping from pneumatically operated components.**

When the valve is operated with a pneumatic actuator or pneumatic valve accessories, exhaust air is vented from the actuator, for example, while the valve is operating and when the valve opens or closes.

- Install the control valve in such a way that vent openings are not located at eye level and the actuator does not vent at eye level in the work position.
- Use suitable mufflers and vent plugs.
- Wear eye protection when working in close proximity to pneumatic fittings and in the danger zone of the vent openings.

#### **Crush hazard arising from moving parts.**

The control valve contains exposed moving parts (actuator stem and plug/piston stem), which can injure hands or fingers if inserted into the valve.

- Do not insert hands or finger into the yoke while the air supply is connected to the actuator.
- Before working on the control valve, disconnect and lock the pneumatic air supply as well as the control signal.
- Do not impede the movement of the actuator stem and plug/piston stem by inserting objects into the yoke.
- Before unblocking the actuator stem and plug/piston stem after they have become blocked (e.g. due to seizing up after remaining in the same position for a long time), release any stored energy in the actuator (e.g. spring compression). See associated actuator documentation.

#### **Risk of personal injury due to preloaded springs in pneumatic actuators.**

Valves in combination with pneumatic actuators with preloaded springs are under tension. These control valves with SAMSON pneumatic actuators can be identified by the long bolts protruding from the bottom of the actuator.

- Before starting any work on the actuator, which requires the actuator to be opened, or when the actuator stem has become blocked, relieve the compression from the preloaded springs (see associated actuator documentation).



**⚠ WARNING**

**Risk of personal injury due to incorrect removal of the anti-rotation fixture under tension.**

Once the actuator has been mounted on the valve and the assembly is ready for use, the clamps of the anti-rotation fixture on the plug stem are under tension.

- Follow the instructions in this document during mounting or removal.
- Remove the actuator from the valve or otherwise ensure that it cannot transmit any forces to the actuator stem before removing the anti-rotation fixture from the plug stem.

**Risk of personal injury due to residual process medium in the valve.**

While working on the valve, residual medium can flow out of the valve and, depending on its properties, cause personal injury, e.g. (chemical) burns.

- Follow the standard operating procedures provided by the plant operator.  
In the event of a potential risk:
  - If possible, drain the process medium from the plant sections affected and from the valve.
  - Wear protective clothing, safety gloves, respiratory protection and eye protection.

**Risk of personal injury due to pressurized components and as a result of process medium being discharged.**

Valves with a bellows seal have a test connection at the top on the intermediate piece (22).

- Do not loosen the screw on the test connection while the valve is pressurized.

**Exposure to hazardous substances poses a serious risk to health.**

Certain lubricants and cleaning agents are classified as hazardous substances. These substances have a special label and a material safety data sheet (MSDS) issued by the manufacturer.

- Make sure that an MSDS is available for any hazardous substance used. If necessary, contact the manufacturer to obtain an MSDS.
- Inform yourself about the hazardous substances and their correct handling.

### **WARNING**

**Risk of personal injury due to incorrect operation, use or installation as a result of information on the valve being illegible.**

Over time, markings, labels and nameplates on the valve may become covered with dirt or become illegible in some other way. As a result, hazards may go unnoticed and the necessary instructions not followed. There is a risk of personal injury.

- Keep all relevant markings and inscriptions on the device in a constantly legible state.
- Immediately renew damaged, missing or incorrect nameplates or labels.

## 1.3 Notes on possible property damage

### **NOTICE**

**Risk of valve damage due to contamination (e.g. solid particles) in the pipeline.**

The plant operator is responsible for cleaning the pipelines in the plant.

- Flush the pipelines before start-up.

**Risk of valve damage due to unsuitable medium properties.**

The valve is designed for a process medium with defined properties.

- Only use the process medium specified for sizing the equipment.

**Risk of leakage and valve damage due to over- or under-torquing.**

Observe the specified torques when tightening control valve components. Excessive tightening torques lead to parts wearing out more quickly. Parts that are too loose may cause leakage.

- Observe tightening torques.

**Risk of valve damage due to the use of unsuitable tools.**

Certain tools are required to work on the valve.

- Only use tools approved by SAMSON.

**! NOTICE**

**Risk of valve damage due to the use of unsuitable lubricants.**

The lubricants to be used depend on the valve material. Unsuitable lubricants may corrode and damage surfaces.

→ Only use lubricants approved by SAMSON.

**Risk of the process medium being contaminated through the use of unsuitable lubricants and/or contaminated tools and components.**

→ If necessary, keep the valve and the tools used free from solvents and grease.

→ Make sure that only suitable lubricants are used.

## 1.4 Notes on the use of an RFID tag

The RFID tag is subject to certain restrictions due to its application range (technical specifications).

- Observe the explosion protection certificates of the RFID tag when it is to be used on valves installed in potentially explosive atmospheres.
- Do not expose the RFID tag to strong electric fields.
- Avoid electrostatic charging.
- Observe the application range (technical specifications) of the RFID tag.

## 1.5 Warnings on the device

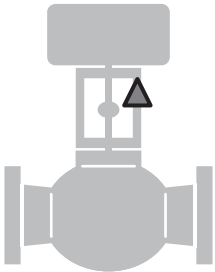
Warning symbols	Meaning of the warning	Location on the device
	<p>Warning against moving parts There is a risk of injury to hands or fingers due to the stroking movement of the actuator stem and plug/piston stem if they are inserted into the yoke while the air supply is connected to the actuator.</p>	



## 2 Markings on the device

The nameplate shown was up to date at the time of publication of this document. The nameplate on the device may differ from the one shown.

### 2.1 Valve nameplate

The nameplate (80) is affixed to the yoke of the valve (see Fig. 2-1).

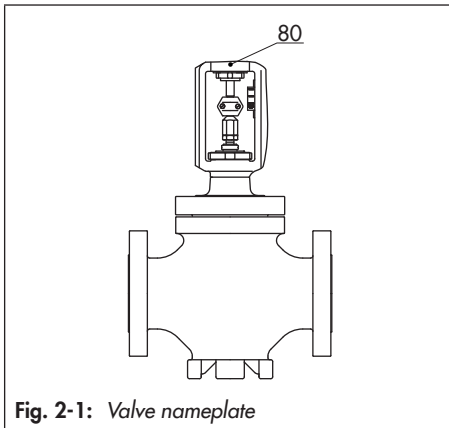

Fig. 2-1: Valve nameplate

**i Note**

Fig. 2-2 and the inscription table list all possible characteristics and options that may appear on a valve nameplate. Only the inscriptions relevant to the ordered Type 251GR Valve actually appear on the nameplate.

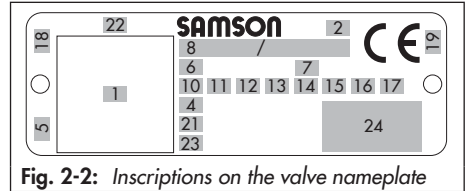

Fig. 2-2: Inscriptions on the valve nameplate

Item	Inscription meaning
1	Identification code (scannable)
2	Type designation
4	Material
5	Month and year of manufacture
6	Nominal size: DIN: <b>DN</b> · ANSI: <b>NPS</b> · JIS: <b>DN</b>
7	Pressure rating: DIN: <b>PN</b> · ANSI: <b>CL</b> · JIS: <b>K</b>
8	Order number/item
10	Flow coefficient: DIN: <b>KVS</b> · ANSI: <b>CV</b>
11	Characteristic: %: equal percentage · <b>LIN</b> : linear <b>mod-lin</b> : modified linear <b>NO/NC</b> : on/off service
12	Seat-plug seal: <b>ME</b> : metal · <b>HA</b> : carbide metal · <b>ST</b> : metal base material with Stellite® facing <b>KE</b> : ceramic · <b>PT</b> : PTFE soft seal · <b>PK</b> : PEEK soft seal
13	Seat code (trim material): on request
14	Pressure balancing: DIN: <b>D</b> · ANSI/JIS: <b>B</b>
	Version: <b>M</b> : mixing valve · <b>V</b> : diverting valve

## Markings on the device

Item	Inscription meaning
15	Noise reduction: <b>1</b> : flow divider (ST) 1 · <b>2</b> : ST 2 · <b>3</b> : ST 3 · <b>1/PSA</b> : ST 1 standard and integrated in seat for PSA valve · <b>AC-1/AC-2/AC-3/AC-5</b> : anti-cavitation trim, versions 1 to 5 <b>LK</b> : perforated plug · <b>LK1/LK2/LK3</b> : perfo- rated plug with flow divider ST 1 to ST 3 · <b>MHC1</b> : multi-hole cage · <b>FDC1</b> : flow divider cage · <b>CC1</b> : combi cage · <b>ZT1</b> : zero travel · <b>LDB</b> : Low dB
16	PSA version: <b>PSA</b>
17	Cage/seat style: <b>CS</b> : clamped-in seat · <b>CG</b> : guided cage · <b>SS</b> : screwed-in seat · <b>SF</b> : suspended cage, flanged seat
18	Country of origin
19	ID of the notified body (EU), for example: – <b>0062</b> for Bureau Veritas Services SAS, 8 Cours du Triangle, 92800 PUTEAUX – LA DEFENSE
21	<b>PED</b> : Pressure Equipment Directive <b>G1/G2</b> : gases and vapors Fluid group 1 = hazardous Fluid group 2 = other <b>L1/L2</b> : liquids Fluid group 1 = hazardous Fluid group 2 = other <b>I/II/III</b> : Category 1 to 3
22	Serial number
23	Hardware version (NE 53)
24	Other marks of conformity



### Tip

*SAMSON recommends to include the device's serial number (22 on the nameplate) and/or its material number (as specified in*

*the order confirmation) in the plant documentation for the associated tag number. The serial number enables you to view the device's current technical data as configured by SAMSON. The material number enables you to view the device's technical data as configured by SAMSON upon delivery of the device. To view these data, go to our website at ► [www.samsongroup.com](http://www.samsongroup.com) > Products > Electronic nameplate.*

*For example, you can also use the associated information to order a new nameplate from our after-sales service, if required.*

## 2.2 Actuator nameplate

See associated actuator documentation.

## 2.3 Material identification number

The seat and plug of the valves have an item number written on them. You can contact us stating this item number to find out which material is used. Additionally, a seat code is used to identify the trim material. This seat code is specified on the nameplate.

## 2.4 Label when an adjustable packing is installed

An instructional label is affixed to the valve when an adjustable packing is installed (see Fig. 2-3).



**Fig. 2-3:** *Label when an adjustable packing is installed*

## 2.5 Optional RFID tag

The RFID tag is located directly next to the nameplate on valves ordered with the RFID tag option. It contains the same data as the identification code on the electronic nameplate. It can be read using a smartphone, tablet or RFID reader.

Application range according to the technical data of RFID tag.





### 3 Design and principle of operation

The Type 251GR Valve is a single-seated globe valve. The Type 251GR Valve is preferably combined with a SAMSON Type 3271 or Type 3277 Pneumatic Actuator.

A seat and plug with plug stem or a cage and piston with piston stem are installed in the valve. The plug/piston stem is connected to the actuator stem by the stem connector clamps and is sealed by a packing. The springs in the pneumatic actuator are located either above or below the diaphragm depending on the selected fail-safe action (see Chapter 3.2). A change in the signal pressure acting on the diaphragm causes the plug/piston to move. The actuator size is determined by the diaphragm area.

The medium flows through the valve in the direction indicated by the arrow. A rise in signal pressure causes the force acting on the diaphragm in the actuator to increase. The springs are compressed. Depending on the selected direction of action, the actuator stem retracts or extends. As a result, the position of the plug in the seat or the position of the piston in the cage changes and determines the flow rate through the valve.



#### Tip

SAMSON recommends the use of positioners with integrated diagnostic firmware (see Chapter 3.5) for valves used for on/off service. The partial stroke test included in this software helps prevent a shut-off valve nor-

ally in its end position from seizing up or getting jammed.

### 3.1 Actuators

The valve is preferably combined with the following SAMSON pneumatic actuators:

- Type 3271 and Type 3277 with 750 cm<sup>2</sup> actuator area or smaller (see Data Sheet ► T 8310-1)
- Type 3271 with 1000 cm<sup>2</sup> actuator area or larger (see Data Sheet ► T 8310-2)
- Type 3271 with 1400-60 cm<sup>2</sup> actuator area (see Data Sheet ► T 8310-3)

The pneumatic actuator (with or without handwheel) can be replaced by another pneumatic actuator in a different size, but with the same travel.

➔ Observe the maximum permissible actuator force.

#### Note

*If the travel range of the actuator is larger than the travel range of the valve, the spring assembly in the actuator must be preloaded so that the travel ranges match. See associated actuator documentation.*

## Design and principle of operation

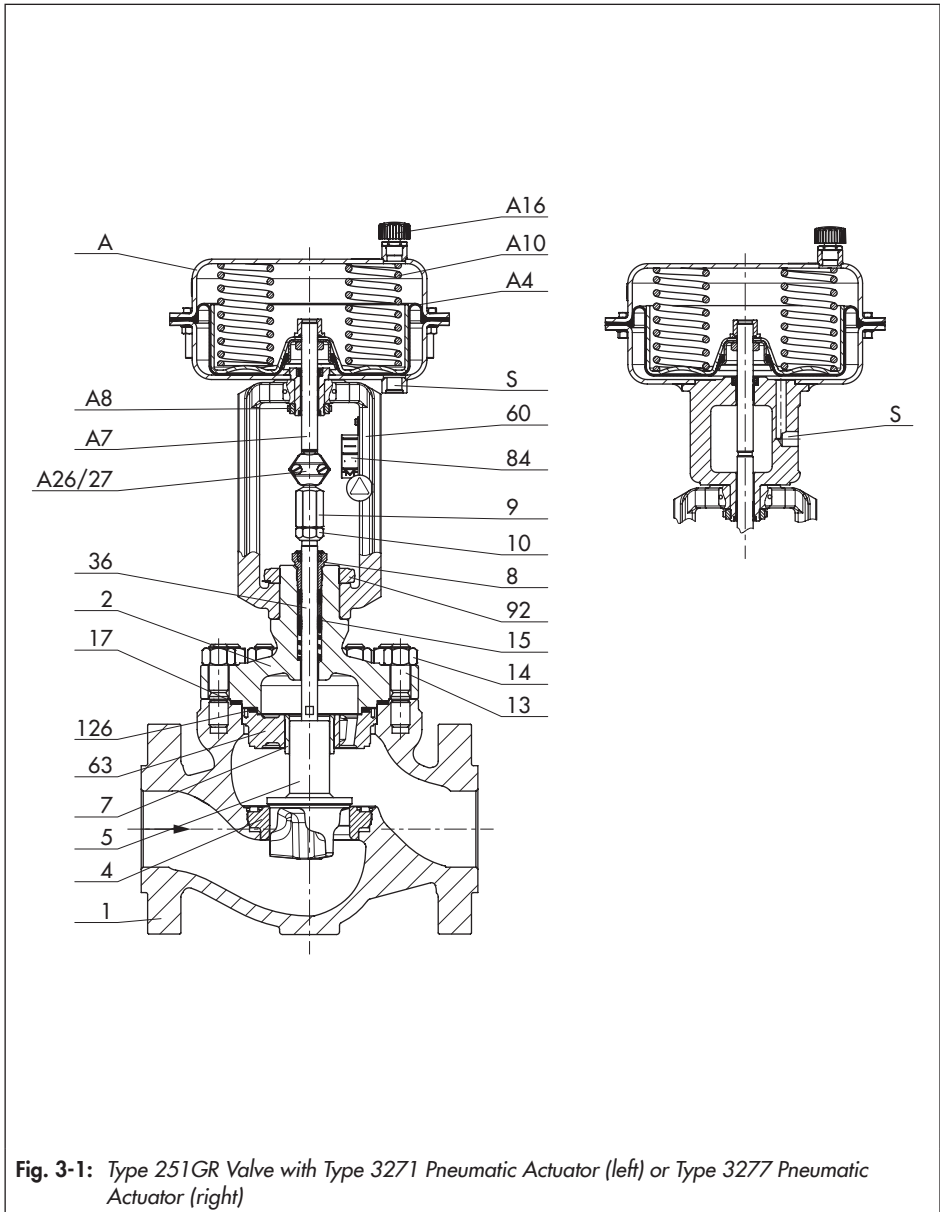

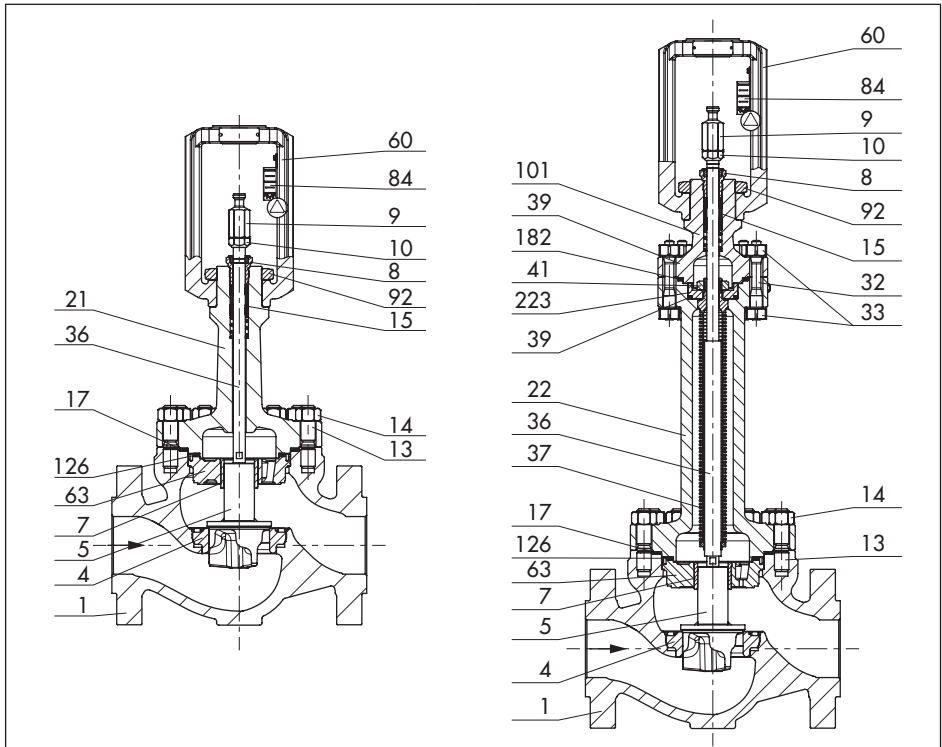
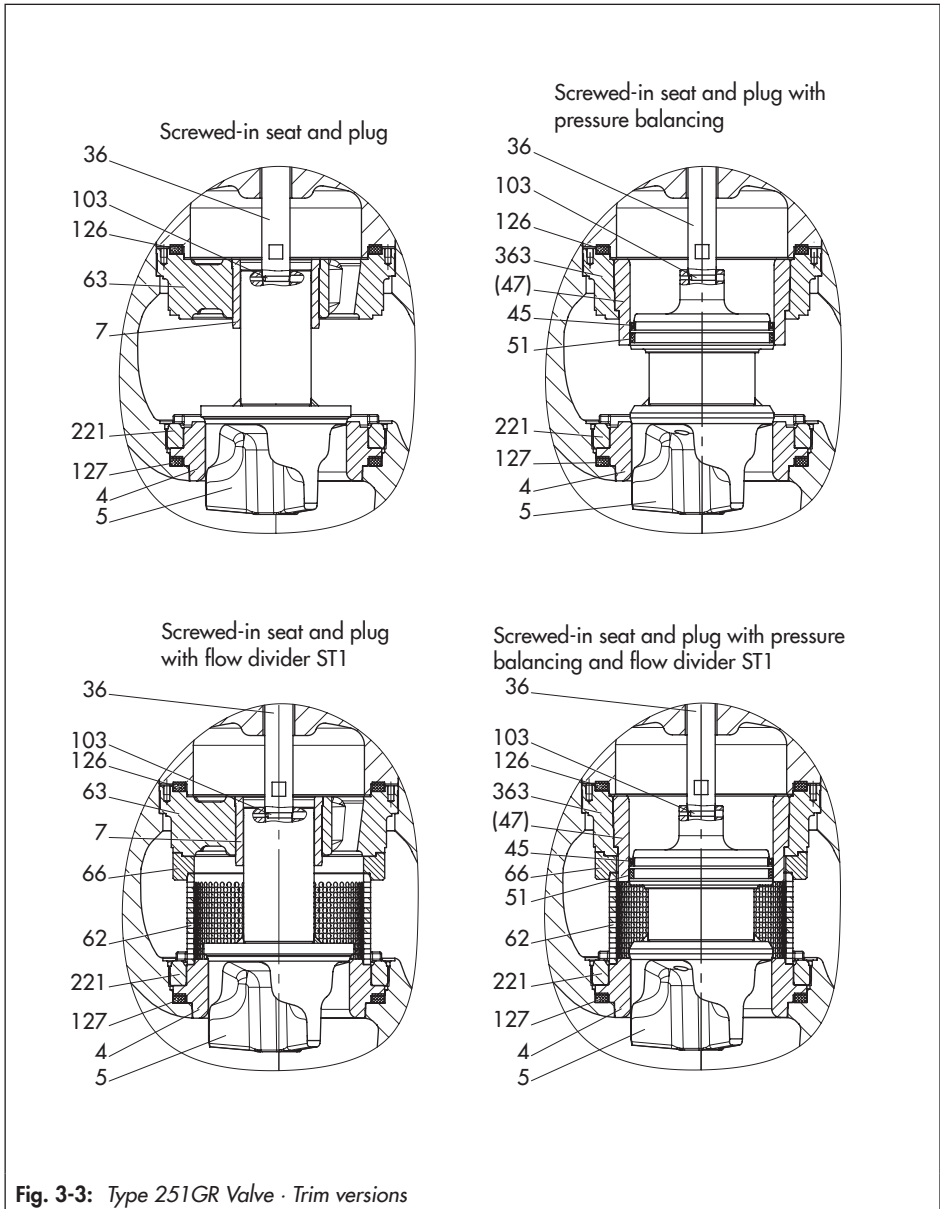

Fig. 3-2: Type 251GR Valve with insulating section (left) and bellows seal (right)

Legend for Fig. 3-1 to Fig. 3-2

- |                                     |                                                |                                          |
|-------------------------------------|------------------------------------------------|------------------------------------------|
| 1 Valve body                        | 22 Intermediate piece with bellows seal        | 126 Spiral gasket                        |
| 2 Standard bonnet                   | 32 Bolt                                        | 182 Spiral gasket                        |
| 4 Seat                              | 33 Nut                                         | 223 Anti-rotation fixture (bellows seal) |
| 5 Plug                              | 36 Plug stem                                   | A Actuator                               |
| 7 Bushing                           | 37 Metal bellows                               | A4 Actuator diaphragm                    |
| 8 Threaded bushing/packing follower | 39 Spiral gasket                               | A7 Actuator stem                         |
| 9 Stem connector nut                | 41 Bellows nut                                 | A8 Ring nut                              |
| 10 Lock nut                         | 60 Yoke                                        | A10 Spring                               |
| 13 Stud                             | 63 Support element                             | A16 Vent plug                            |
| 14 Hex nut                          | 84 Travel indicator scale                      | A26/ A27 Stem connector clamps           |
| 15 Packing                          | 92 Castellated nut                             | S Signal pressure connection             |
| 17 Spiral gasket                    | 101 Valve bonnet (when a bellows seal is used) |                                          |
| 21 Insulating section               |                                                |                                          |

## Design and principle of operation



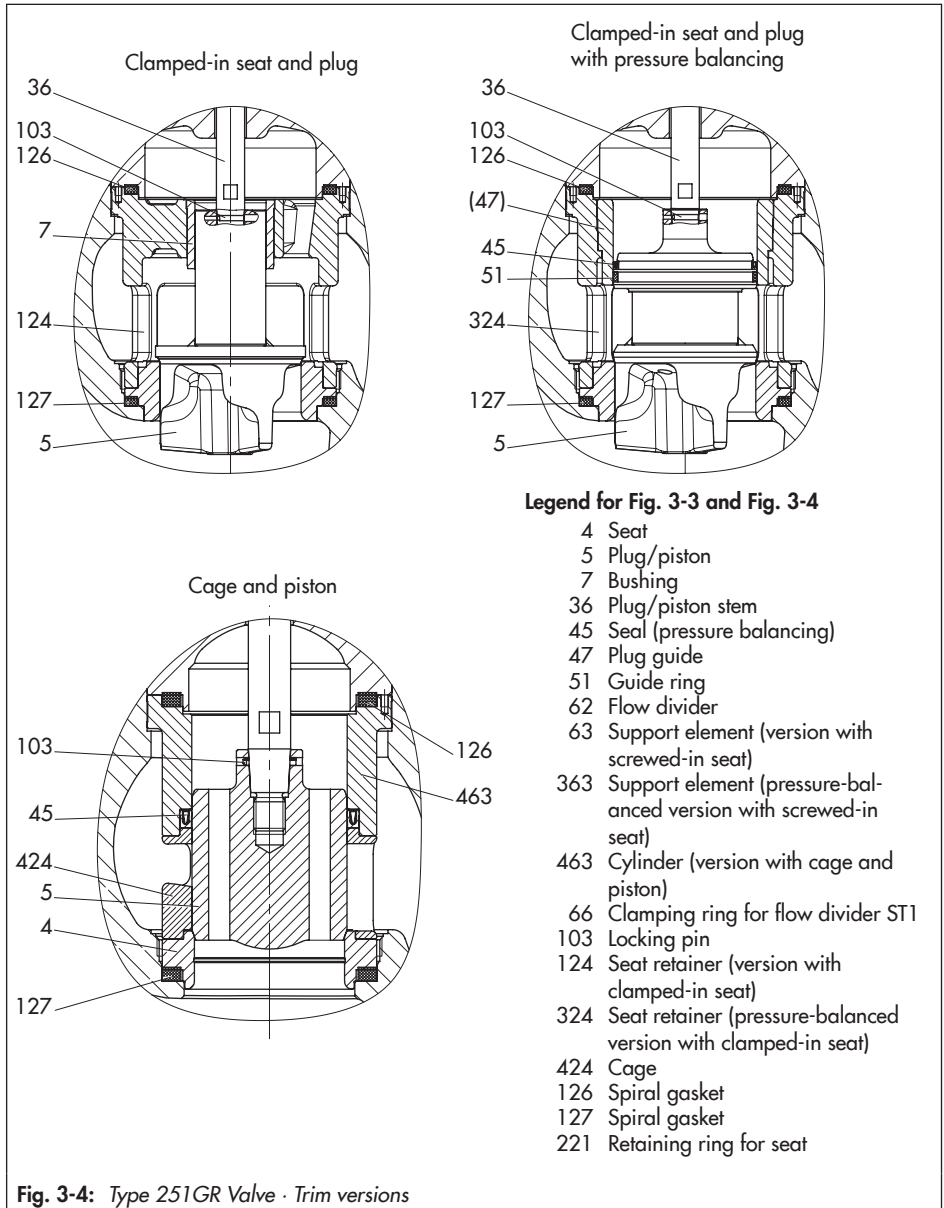

Fig. 3-4: Type 251GR Valve · Trim versions

### 3.2 Fail-safe positions

The fail-safe position of the control valve upon air supply or control signal failure depends on the actuator used (see associated actuator documentation).

#### **SAMSON pneumatic actuators with integrated springs**

The fail-safe action of the SAMSON Type 3271 and Type 3277 Pneumatic Actuators depends on how the compression springs are installed in the actuator.



#### **Tip**

*The actuator's direction of action can be reversed, if required. Refer to the mounting and operating instructions of the pneumatic actuator:*

▶ *EB 8310-X for Type 3271 and Type 3277*

#### **3.2.1 Fail-safe action "actuator stem extends" (FA)**

##### **SAMSON Type 3271 and Type 3277 Actuators**

When the signal pressure is reduced or the air supply fails, the springs move the actuator stem downward and close the valve. The valve opens when the signal pressure is increased enough to overcome the force exerted by the springs.

#### **3.2.2 Fail-safe action "actuator stem retracts" (FE)**

##### **SAMSON Type 3271 and Type 3277 Actuators**

When the signal pressure is reduced or the air supply fails, the springs move the actuator stem upward and open the valve. The valve closes when the signal pressure is increased enough to overcome the force exerted by the springs.

### 3.3 Versions

#### **With insulating section/bellows seal**

The modular design allows an insulating section or bellows seal to be fitted to the standard valve version.

### 3.4 Additional fittings

#### **Strainers**

SAMSON recommends installing a SAMSON strainer upstream of the valve. It prevents solid particles in the process medium from damaging the valve.

#### **Bypass and shut-off valves**

SAMSON recommends installing a shut-off valve both upstream of the strainer and downstream of the valve and installing a bypass line. The bypass ensures that the plant does not need to be shut down for service and repair work on the valve.

### Insulation

Control valves can be insulated to reduce heat energy transfer.

Refer to the instructions in the 'Installation' chapter.

### Test connection

Versions with bellows seal fitted with a test connection (G 1/8) on top on the intermediate piece (22) allow the sealing ability of the bellows to be monitored.

Particularly for liquids and vapors, SAMSON recommends installing a suitable leakage indicator (e.g. a contact pressure gauge, an outlet to an open vessel or an inspection glass).

### Safety guard

For operating conditions that require increased safety (e.g. in cases where the valve is freely accessible to untrained staff), a safety guard must be installed to rule out a crush hazard arising from moving parts (actuator and plug/piston stem). Plant operators are responsible for deciding whether a guard is to be used. The decision is based on the risk posed by the plant and its operating conditions.

### Noise reduction

Trims with flow dividers can be used to reduce noise emission (► T 8081).

## 3.5 Valve accessories

Information Sheet ► T 8350

## 3.6 Technical data

### Control valve identification

The nameplates on the valve and actuator provide information on the control valve version. See the 'Markings on the device' chapter.

---

#### **i** Note

*More information on Type 251GR Valve is available in the following data sheets:*

- ► T 8003-GR (DIN version)
  - ► T 8004-GR (ANSI version)
- 

### Conformity

The Type 251GR Valve bears the CE mark of conformity.



### Temperature range

Depending on the version, the control valve is designed for a temperature range from -20 to +482 °F (-29 to +250 °C). The use of an insulating section or a bellows seal in combination with a high-temperature packing can extend the temperature range from -58 to +1112 °F (-50 to +600 °C) or -58 to +797 °F (-50 to +425 °C) respectively depending on the properties of the materials used.

## Design and principle of operation

### Leakage class

Depending on the version, the following leakage class applies:

Seal (12 on nameplate)	ME, ST	ME, ST
Pressure balancing (14 on nameplate)	–	D/B
Leakage class (according to ANSI/FCI 70-2)	Min. IV	Min. IV

### Noise emissions

SAMSON is unable to make general statements about noise emissions. The noise emissions depend on the valve version, plant facilities and process medium.

### Optional RFID tag

Application range according to the technical specifications and the explosion protection certificates. These documents are available on our website at ► [www.samsongroup.com](http://www.samsongroup.com) > Products > Electronic nameplate.

---

#### **i Note**

*The associated actuator documentation applies to actuators, e.g. SAMSON pneumatic actuators:*

- T 8310-1 for Type 3271 or Type 3277 Pneumatic Actuators up to 750 cm<sup>2</sup> actuator area
  - T 8310-2 for Type 3271 Actuator with 1000 cm<sup>2</sup> actuator area and larger
  - T 8310-3 for Type 3271 Actuator with 1400-60 cm<sup>2</sup> actuator area
- 

## Dimensions and weights

---

#### **i Note**

*See associated actuator documentation for dimensions and weights of the actuators.*

---

Table 3-1 to Table 3-3 provide an overview of the dimensions and weights of the Type 251GR Valve. The lengths and heights in the dimensional drawings are shown on page 3-13.



**Table 3-1:** Dimensions in inch and mm for Type 251GR Valve (NPS ½ to 3)

Valve	NPS		½	1	1½	2	3
Length L Flange RF	Class 150	in	7.25	7.25	8.75	10	11.75
		mm	184	184	222	254	298
	Class 300	in	7.5	7.75	9.25	10.5	12.5
		mm	190	197	235	267	318
	Class 600	in	8	8.25	9.88	11.25	13.25
		mm	203	210	251	286	337
	Class 900	in	11.5	11.5	13.12	14.75	17.38
		mm	292	292	333	375	441
Length L Flange RTJ	Class 150	in	7.25	7.75	9.25	10.5	12.25
		mm	184	197	235	267	311
	Class 300	in	7.94	8.25	9.75	11.12	13.12
		mm	201	210	248	283	334
	Class 600	in	7.94	8.25	9.88	11.37	13.37
		mm	201	210	251	289	340
	Class 900	in	11.5	11.5	13.12	14.87	17.5
		mm	292	292	333	378	444
Length L Welding ends	Class 150 to 600	in	8	8.25	9.88	11.25	13.25
		mm	203	210	251	286	337
	Class 900	in	11	11	13	14.75	18.12
		mm	279	279	330	375	460
Height H4 Standard version	in	5.12	5.51	6.14	6.93	7.87	
	mm	130	140	156	176	200	
Height H4 With <b>insulating section</b>	in	8.86	8.86	10.04	11.42	12.4	
	mm	225	225	255	290	315	
Height H4 With <b>bellows seal</b>	in	On request	16.38	On request	18.27	22.05	
	mm	On request	416	On request	464	560	

## Design and principle of operation

Valve		NPS	½	1	1½	2	3
H8 for actuator	350 cm <sup>2</sup>	in	11.26	11.26	11.26	11.26	11.26
		mm	286	286	286	286	286
	350v2 cm <sup>2</sup>	in	11.26	11.26	11.26	11.26	11.26
		mm	286	286	286	286	286
	355v2 cm <sup>2</sup>	in	11.26	11.26	11.26	11.26	11.26
		mm	286	286	286	286	286
	750v2 cm <sup>2</sup>	in	11.26	11.26	11.26	11.26	11.26
		mm	286	286	286	286	286
	1000 cm <sup>2</sup>	in	13.43	13.43	13.43	13.43	13.43
		mm	341	341	341	341	341
	1400-60 cm <sup>2</sup>	in	13.43	13.43	13.43	13.43	13.43
		mm	341	341	341	341	341
	1400-120 cm <sup>2</sup>	in	–	–	–	20.71	20.71
		mm	–	–	–	526	526
	2800 cm <sup>2</sup>	in	–	–	–	20.71	20.71
		mm	–	–	–	526	526
2x 2800 cm <sup>2</sup>	in	–	–	–	20.71	20.71	
	mm	–	–	–	526	526	
H2 <sup>1)</sup>	Class 150	in	1.75	2.13	2.50	2.99	4.15
		mm	44.5	54	63.5	76	105.5
	Class 300 to 600	in	1.87	2.44	3.05	3.25	4.15
		mm	47.5	62	77.5	82.5	105.5
	Class 900	in	2.38	2.93	3.50	4.25	4.74
		mm	60.5	74.5	89	108	120.5

<sup>1)</sup> The H2 dimension is the distance from the middle of the flow path to the bottom of the valve body. The dimension up to the bottom of the flange may differ. It may be lower or higher. Flange standards (see associated Data Sheet ► T 8004-GR)

**Table 3-2:** Dimensions in inch and mm for Type 251GR Valve (NPS 4 to 8)

Valve		NPS	4	6	8
Length L Flange RF	Class 150	in	13.88	17.75	21.38
		mm	352	451	543
	Class 300	in	14.5	18.62	22.38
		mm	368	473	568
	Class 600	in	15.5	20	24
		mm	394	508	610
	Class 900	in	20.12	28.12	30.75
		mm	511	714	781
Length L Flange RTJ	Class 150	in	14.38	18.25	21.88
		mm	365	464	556
	Class 300	in	15.12	19.25	23
		mm	384	489	584
	Class 600	in	15.62	20.12	24.12
		mm	397	511	613
	Class 900	in	20.24	28.24	30.87
		mm	514	717	784
Length L Welding ends	Class 150 to 600	in	15.5	20	24
		mm	394	508	610
	Class 900	in	20.12	30.25	32.75
		mm	511	768	832
Height H4 <b>Standard version</b>	in	9.84	12.60	15.75	
	mm	250	320	400	
Height H4 With <b>insulating section</b>	in	14.76	20.87	24.02	
	mm	375	530	610	
Height H4 With <b>bellows seal</b>	in	22.64	33.90	On request	
	mm	575	861	On request	

## Design and principle of operation

Valve		NPS	4	6	8
H8 for actuator	350 cm <sup>2</sup>	in	11.26	19.80	–
		mm	286	503	–
	350v2 cm <sup>2</sup>	in	11.26	19.80	–
		mm	286	503	–
	355v2 cm <sup>2</sup>	in	11.26	19.80	–
		mm	286	503	–
	750v2 cm <sup>2</sup>	in	11.26	19.80	–
		mm	286	503	–
	1000 cm <sup>2</sup>	in	13.43	19.80	19.80
		mm	341	503	503
	1400-60 cm <sup>2</sup>	in	13.43	19.80	19.80
		mm	341	503	503
	1400-120 cm <sup>2</sup>	in	20.71	23.15	23.15
		mm	526	588	588
	2800 cm <sup>2</sup>	in	20.71	23.15	23.15
		mm	526	588	588
2x 2800 cm <sup>2</sup>	in	20.71	23.15	23.15	
	mm	526	588	588	
H2 <sup>1)</sup>	Class 150	in	5.35	7.28	8.46
		mm	136	185	215
	Class 300 to 600	in	5.35	7.28	8.46
		mm	136	185	215
	Class 900	in	5.75	7.50	–
		mm	146	190.5	–

<sup>1)</sup> The H2 dimension is the distance from the middle of the flow path to the bottom of the valve body. The dimension up to the bottom of the flange may differ. It may be lower or higher. Flange standards (see associated Data Sheet ► T 8004-GR)

Dimensional drawings

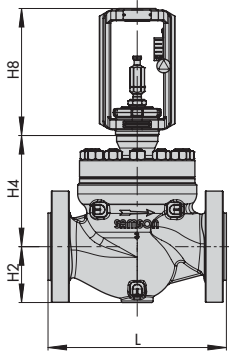

Standard version

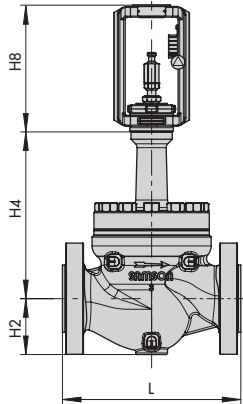

Version with insulating section

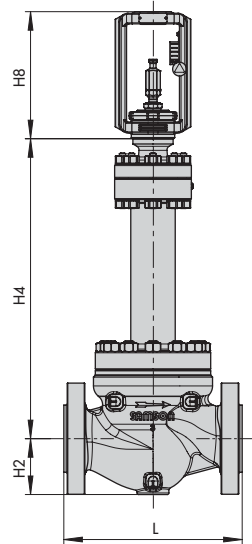

Version with bellows seal

## Design and principle of operation

**Table 3-3:** *Weights <sup>1)</sup> in lbs and kg (approx.) for Type 251GR Valve with RF flanges according to ASME B16.5*

Valve	NPS	½	1	1½	2	3	4	6	8	
<b>Standard version</b>										
Valve without actuator	Class 150	lbs	20	29	37	64	101	148	298	511
		kg	9	13	17	29	46	67	135	232
	Class 300	lbs	22	33	46	68	112	174	355	589
		kg	10	15	21	31	51	79	161	267
	Class 600	lbs	22	33	49	75	128	225	470	820
		kg	10	15	22	34	58	102	213	372
	Class 900	lbs	33	46	66	119	194	298	681	-
		kg	15	21	30	54	88	135	309	
<b>Version with insulating section</b>										
Valve without actuator	Class 150	lbs	24	33	44	68	115	168	355	589
		kg	11	15	20	31	52	76	161	267
	Class 300	lbs	24	35	51	75	128	196	417	672
		kg	11	16	23	34	58	89	189	305
	Class 600	lbs	26	37	53	82	132	231	500	851
		kg	12	17	24	37	60	105	227	386
	Class 900	lbs	37	51	71	123	198	304	712	-
		kg	17	23	32	56	90	138	323	
<b>Version with bellows seal</b>										
Valve without actuator	Class 150	lbs	-	29	37	60	93	146	282	467
		kg		13	17	27	42	66	128	212
	Class 300	lbs	-	33	44	64	106	174	346	551
		kg		15	20	29	48	79	157	250
	Class 600	lbs	-	35	49	71	112	201	414	688
		kg		16	22	32	51	91	188	312
	Class 900	lbs	-	-	-	-	-	-	-	-
		kg		-	-	-	-	-	-	-

<sup>1)</sup> The weights specified apply to a specific standard device configuration. Weights of other valve configurations may differ depending on the version (material, trim etc.).

## 4 Shipment and on-site transport

The work described in this chapter is to be performed only by personnel appropriately qualified to carry out such tasks.

### 4.1 Accepting the delivered goods

After receiving the shipment, proceed as follows:

1. Check the scope of delivery. Check that the specifications on the valve nameplate match the specifications in the delivery note. See the 'Markings on the device' chapter for nameplate details.
2. Check the shipment for transportation damage. Report any damage to SAMSON and the forwarding agent (refer to delivery note).
3. Determine the weight and dimensions of the units to be lifted and transported (see transport documents) in order to select the appropriate lifting equipment and lifting accessories, if required.

### 4.2 Removing the packaging from the valve

Observe the following sequence:

- Do not open or remove the packaging until immediately before lifting to install the valve into the pipeline.
- Leave the control valve in its transport container or on the pallet to transport it on site.

- Do not remove the protective caps from the inlet and outlet until immediately before installing the valve into the pipeline. They prevent foreign particles from entering the valve.
- Dispose and recycle the packaging in accordance with the local regulations.

### 4.3 Transporting and lifting the valve

---

#### **⚠ DANGER**

***Danger due to suspended loads falling.***

- *Stay clear of suspended or moving loads.*
  - *Close off and secure the transport paths.*
- 

#### **⚠ WARNING**

***Risk of lifting equipment tipping over and risk of damage to lifting accessories due to exceeding the rated lifting capacity.***

- *Only use approved lifting equipment and accessories whose minimum lifting capacity is higher than the weight of the valve (including actuator and packaging, if applicable).*
- 

#### **⚠ WARNING**

***Risk of personal injury due to the control valve tipping over.***

- *Observe the valve's center of gravity.*
  - *Secure the valve against tipping over or turning.*
-

### NOTICE

#### **Risk of valve damage due to incorrectly attached slings.**

The lifting eyelet/eyebolt on SAMSON actuators is only intended for mounting and removing the actuator as well as lifting the actuator without valve. Do not use this lashing point to lift the entire control valve assembly.

- When lifting the control valve, make sure that the slings attached to the valve body bear the entire load.
- Do not attach load-bearing slings to the actuator, handwheel or any other mounting parts.
- Observe lifting instructions (see Chapter 4.3.2).

### Tip

A swivel hoist can be screwed into SAMSON actuators with a female thread on the top diaphragm case in place of the eyebolt (see associated actuator documentation).

In contrast to the lifting eyelet/eyebolt, the swivel hoist is designed for setting a control valve assembly upright.

The sling between the swivel hoist and rigging equipment (hook, shackle etc.) must not bear any load when lifting a control valve assembly. The sling only protects the control valve from tilting while being lifted.

### Tip

Our after-sales service can provide more detailed transport and lifting instructions on request.

## 4.3.1 Transporting the valve

The control valve can be transported using lifting equipment (e.g. crane or forklift).

- Leave the control valve in its transport container or on the pallet to transport it.
- Observe the transport instructions.

### Transport instructions

- Protect the control valve against external influences (e.g. impact).
- Do not damage the corrosion protection (paint, surface coatings). Repair any damage immediately.
- Protect the piping and any mounted valve accessories against damage.
- Protect the control valve against moisture and dirt.
- The permissible transportation temperature of standard control valves is  $-4$  to  $+149$  °F ( $-20$  to  $+65$  °C).

### Note

Contact our after-sales service for the transportation temperatures of other valve versions.



### 4.3.2 Lifting the valve

To install a large valve into the pipeline, use lifting equipment (e.g. crane or forklift) to lift it.

#### Lifting instructions

- Use a hook with safety latch (see Fig. 4-1) to secure the slings from slipping off the hook during lifting and transporting.
- Secure slings against slipping.
- Make sure the slings can be removed from the device once it has been installed into the pipeline.
- Prevent the control valve from tilting or tipping over.
- Do not leave loads suspended when interrupting work for longer periods of time.
- Make sure that the axis of the pipeline is always horizontal during lifting and the axis of the plug/piston stem is always vertical.
- Make sure that the additional sling between the lashing point on the actuator and rigging equipment (hook, shackle etc.) does not bear any load when lifting valves with an actuator that has a lifting eyelet/eyebolt on it. The sling only protects the control valve from tilting while being lifted. Before lifting the control valve, tighten the sling.

#### Valve version with flanges

1. Attach one sling to each flange of the body and to the rigging equipment (e.g. hook) of the crane or forklift (see Fig. 4-1).
2. **Mounted actuator with lashing point:** Attach other slings to the lashing point on the actuator and to the rigging equipment.
3. Carefully lift the control valve. Check whether the lifting equipment and accessories can bear the weight.
4. Move the control valve at an even pace to the site of installation.
5. Install the valve into the pipeline (see the 'Installation' chapter).
6. After installation in the pipeline, check whether the flanges are bolted tight and the valve in the pipeline holds.
7. Remove slings.

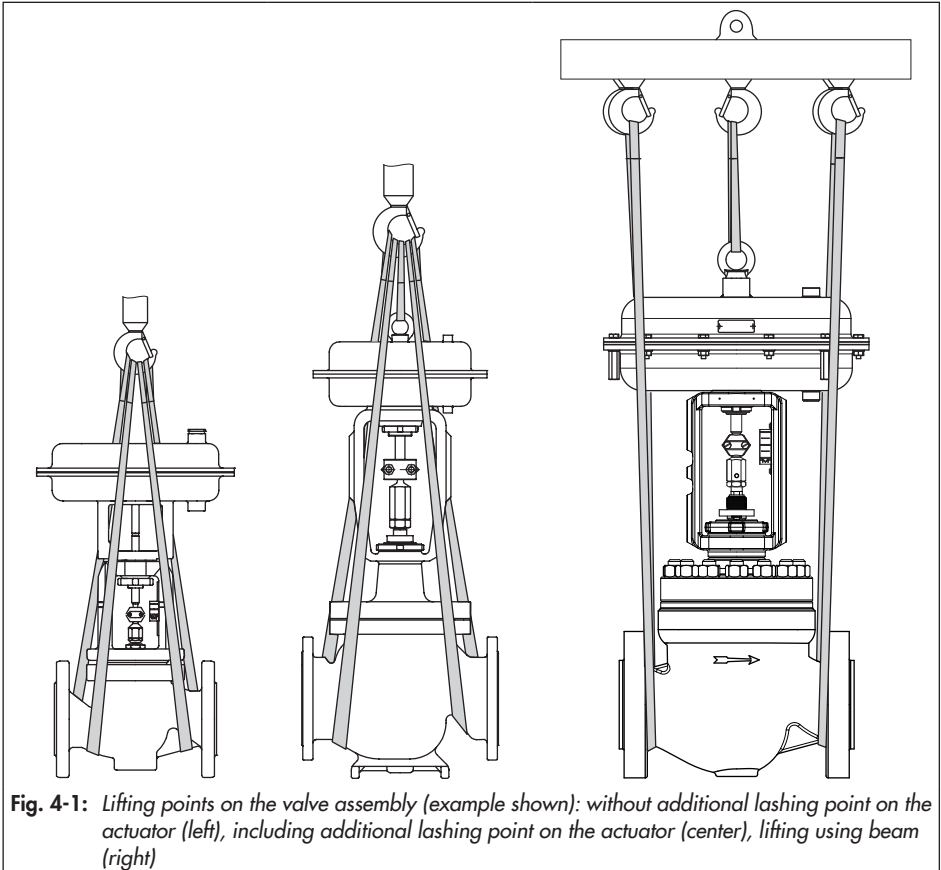

## 4.4 Storing the valve

### NOTICE

**Risk of valve damage due to improper storage.**

- Observe the storage instructions.
- Avoid longer storage periods.
- Contact SAMSON in case of different storage conditions or longer storage times.

### Note

SAMSON recommends to regularly check the control valve and the prevailing storage conditions during long storage periods.

### Storage instructions

- Protect the control valve against external influences (e.g. impact).
- Secure the valve in the stored position against slipping or tipping over.
- Do not damage the corrosion protection (paint, surface coatings). Repair any damage immediately.
- Protect the control valve against moisture and dirt. Store it at a relative humidity of less than 75 %. In damp spaces, prevent condensation. If necessary, use a drying agent or heating.
- Make sure that the ambient air is free of acids or other corrosive media.
- The permissible storage temperature of standard control valves is  $-4$  to  $+149$  °F ( $-20$  to  $+65$  °C). Contact our after-sales

service for the storage temperatures of other valve versions.

- Do not place any objects on the control valve.
- For storage periods longer than 4 months, SAMSON recommends storing the following valves upright with the actuator on top:
  - $\geq$ NPS 4 in versions with pressure balancing
  - $\geq$ NPS 6 in versions without pressure balancing

### Special storage instructions for elastomers

Elastomer, e.g. actuator diaphragm

- To keep elastomers in shape and to prevent cracking, do not bend them or hang them up.
- SAMSON recommends a storage temperature of  $59$  °F ( $15$  °C) for elastomers.
- Store elastomers away from lubricants, chemicals, solutions and fuels.

### Tip

Our after-sales service can provide more detailed storage instructions on request.



## 5 Installation

The work described in this chapter is to be performed only by personnel appropriately qualified to carry out such tasks.

Plant operators must ensure that, after installation of the device, the operating personnel can perform all necessary work safely and easily access the device from the work position.

### 5.1 Installation conditions

#### Work position

The work position for the control valve is the front view looking onto the operating controls (including valve accessories).

#### Pipeline routing

The inlet and outlet lengths (see Table 5-1) vary depending on several variables and process conditions and are intended as recommendations. Contact SAMSON if the lengths are significantly shorter than the recommended lengths.

**Table 5-1:** *Inlet and outlet lengths*

State of process medium	Valve conditions	Inlet length a	Outlet length b
Gas	$Ma \leq 0.3$	2	4
	$0.3 \leq Ma \leq 0.7$	2	10
Vapor	$Ma \leq 0.3$ <sup>1)</sup>	2	4
	$0.3 \leq Ma \leq 0.7$ <sup>1)</sup>	2	10
	Wet steam (percentage of condensate > 5 %)	2	20
Liquid	Free of cavitation/ $w < 10$ m/s	2	4
	Cavitation producing noise/ $w \leq 3$ m/s	2	4
	Cavitation producing noise/ $3 < w < 5$ m/s	2	10
	Critical cavitation/ $w \leq 3$ m/s	2	10
	Critical cavitation/ $3 < w < 5$ m/s	2	20
Flashing	–	2	20
Multi-phase	–	10	20

<sup>1)</sup> No wet steam

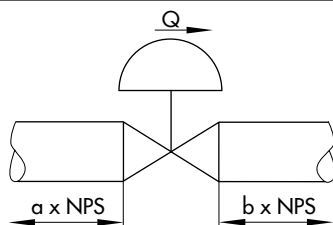

Q Flow rate  
a Inlet length  
b Outlet length

## Installation

To ensure that the valve functions properly, proceed as follows:

- Observe the recommended inlet and outlet lengths (see Table 5-1). Contact SAMSON if the valve conditions or states of the medium process deviate.
- Install the valve free of stress and with the least amount of vibrations as possible. Read sections "Mounting position" and "Support or suspension" in this chapter.
- Install the valve allowing sufficient space to remove the actuator and valve or to perform service and repair work on them.

### Mounting position

Generally, SAMSON recommends installing the valve with the actuator upright and on top of the valve.

- Contact SAMSON if the mounting position is not as specified above.
- In versions in nominal size NPS 4 and larger, the valve must be installed with the actuator on top.

### Support or suspension

Depending on the valve version and mounting position, the valve, actuator and pipeline must be supported or suspended.

- Valves, which are not installed in the pipeline in the upright position with the actuator on top, must be supported or suspended.

---

#### **i** Note

*The plant engineering company is responsible for selecting and implementing a suitable*

*support or suspension of the installed control valve and the pipeline.*

---

### Valve accessories

- During connection of valve accessories, make sure that they are easily accessible and can be operated safely from the work position.

### Vent plugs

Vent plugs are screwed into the exhaust air ports of pneumatic and electropneumatic devices. They ensure that any exhaust air that forms can be vented to the atmosphere (to avoid excess pressure in the device). Furthermore, the vent plugs allow air intake to prevent a vacuum from forming in the device.

- Locate the vent plug on the opposite side to the work position of operating personnel.

## 5.2 Preparation for installation

Before installation, make sure the following conditions are met:

- The valve is clean.
- The valve and all valve accessories (including piping) are not damaged.
- The valve data on the nameplate (type designation, nominal size, material, pressure rating and temperature range) match the plant conditions (nominal size and pressure rating of the pipeline, medium temperature etc.). See the 'Markings on the device' chapter for nameplate details.

- The requested or required additional pipe fittings (see the 'Additional fittings' chapter) have been installed or prepared as necessary before installing the valve.

### NOTICE

#### **Risk of control valve damage due to incorrect insulation.**

- Only insulate control valves up to the bonnet flange of the valve body (see Fig. 5-1). This also applies to versions with bellows seal or insulating section at medium temperatures below 32 °F (0 °C) or above 428 °F (220 °C). If the insulating section is insulated, it will not function properly.
- Do not insulate valves mounted to comply with NACE MR0175 requirements and which have nuts and bolts that are not suitable for sour gas environments.

Proceed as follows:

- Lay out the necessary material and tools to have them ready during installation work.
- Flush the pipelines.

### Note

The plant operator is responsible for cleaning the pipelines in the plant.

- For steam applications, dry the pipelines. Moisture will damage the inside of the valve.
- Check any mounted pressure gauges to make sure they function properly.
- When the valve and actuator are already assembled, check the tightening torques of the bolted joints. Components may loosen during transport.

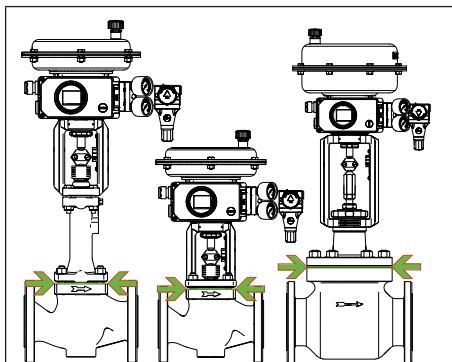

**Fig. 5-1:** Limit of insulation for control valves (example shown)

### 5.3 Mounting the device

The activities listed below are necessary to install the valve and before it can be started up.

---

#### ! NOTICE

##### **Risk of control valve damage due to over- or under-torquing.**

*Observe the specified torques when tightening control valve components. Excessive tightening torques lead to parts wearing out more quickly. Parts that are too loose may cause leakage.*

→ *Observe the specified tightening torques.*

---

#### ! NOTICE

##### **Risk of valve damage due to the use of unsuitable tools.**

→ *Only use tools approved by SAMSON.*

---

#### 5.3.1 Mounting the external anti-rotation fixture

Before mounting the actuator, the external anti-rotation fixture must be mounted onto the plug stem in some cases. The valve must be closed beforehand.

For SAMSON Type 3271 and Type 3277 Actuators with Type 3273 Hand-operated Actuator, observe the mounting and operating instructions of the hand-operated actuator (handwheel) to mount the anti-rotation fixture ► EB 8312-X.

#### a) Standard version for nominal size NPS 6 and larger

See Fig. 5-2 and Fig. 5-3

##### 1. Version with packing flange:

- i. Gradually unthread the two packing nuts (163) at the hex head in a criss-cross pattern.
- ii. Lift the two packing nuts (including disk springs when packing flange is loaded by external spring elements) as well as the packing flange (162) upward over the studs (164) off the valve bonnet (2/21).

##### Version with centrally fastened packing:

Continue as described in step 2.

2. Insert ball bearings (310) into the recesses in the bonnet.
3. Place the yoke (3) on the bonnet in such a way that the ball bearings fit into the recesses of the yoke.
4. Fasten the yoke (3) using the castellated nut (92).
5. Version with packing flange:
  - i. Place the packing flange (162) over the studs (164) of the valve bonnet (2/21) on the packing follower (8).
  - ii. Thread the two packing nuts (163) (including disk springs when packing flange is loaded by external spring elements) onto the studs (164) and hand-tighten them. Guide the packing nuts (163) through the holes in the packing flange of the spring-loaded packing.



**Version with centrally fastened packing:**

Continue as described in step 6.

6. Fasten the hanger (83) and warning label (255), if applicable, to the yoke using the screws (82).
7. Position the travel indicator scale (84) on the hanger (83) with the screws (85) according to Table 5-4.
8. Use a soft-faced hammer or lever press to press the sliding washers (309) with their beveled part first (without using any lubricant) into the recesses of the clamps (301) as far as they will go. Remove any excess material.
9. Apply a thin film of lubricant (114) to the threads of the stem (9) and screws (303).

**NOTICE*****Impaired functioning due to incorrectly applied lubricant.***

→ *Do not apply any lubricant to the threads of the clamps (301) or the plug stem.*

10. Position the clamps (301) and stem (9) on the plug stem according to Table 5-4 and tighten screws (303) and washers (304) by hand.
11. Mount the actuator (see Chapter 5.3.2).
12. Thread the stem (9) upwards until the head of the stem rests on the extended actuator stem.
13. Retract the actuator stem to relieve the stem (9).

14. Gradually tighten the screws (303) in a crisscross pattern. Observe the tightening torques specified in Table 5-2.

**Table 5-2: Tightening torques**

Screw size	Tightening torque [Nm]
M12	50
M16	121

15. Check and ensure the following:
  - There is a nominal clearance of 0.5 to 1 mm between the sliding washers and their contact surface on the yoke on each side (see detailed view Y in Fig. 5-3).
  - The anti-rotation fixture does not get stuck on the yoke and can move freely in the direction of travel.
16. Extend the actuator stem again and mount the stem connector clamps.

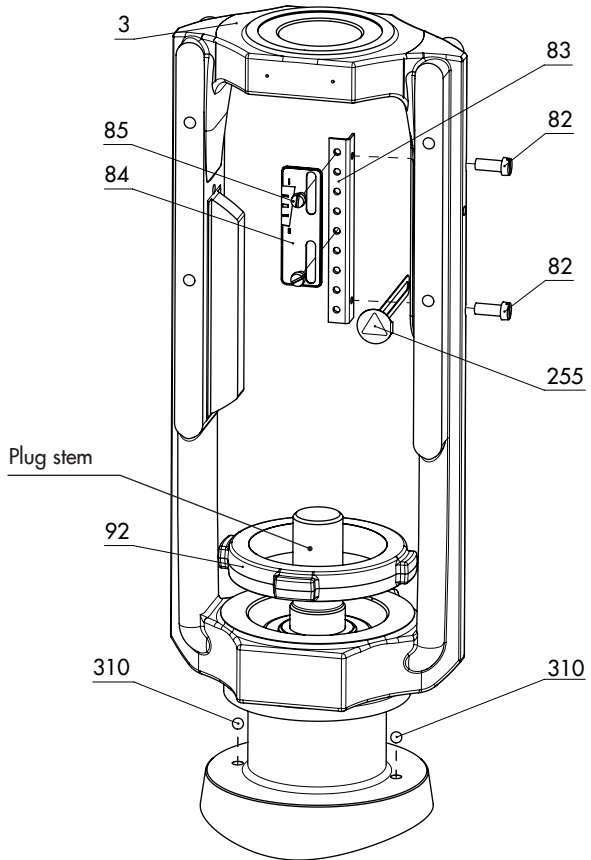

**Legend**

- 3 Yoke
- 82 Screws
- 83 Hanger
- 84 Travel indicator scale
- 85 Screws
- 92 Castellated nut
- 255 Warning label
- 310 Ball bearing

**Fig. 5-2:** Overview of yoke assembly with travel indicator scale in the standard version

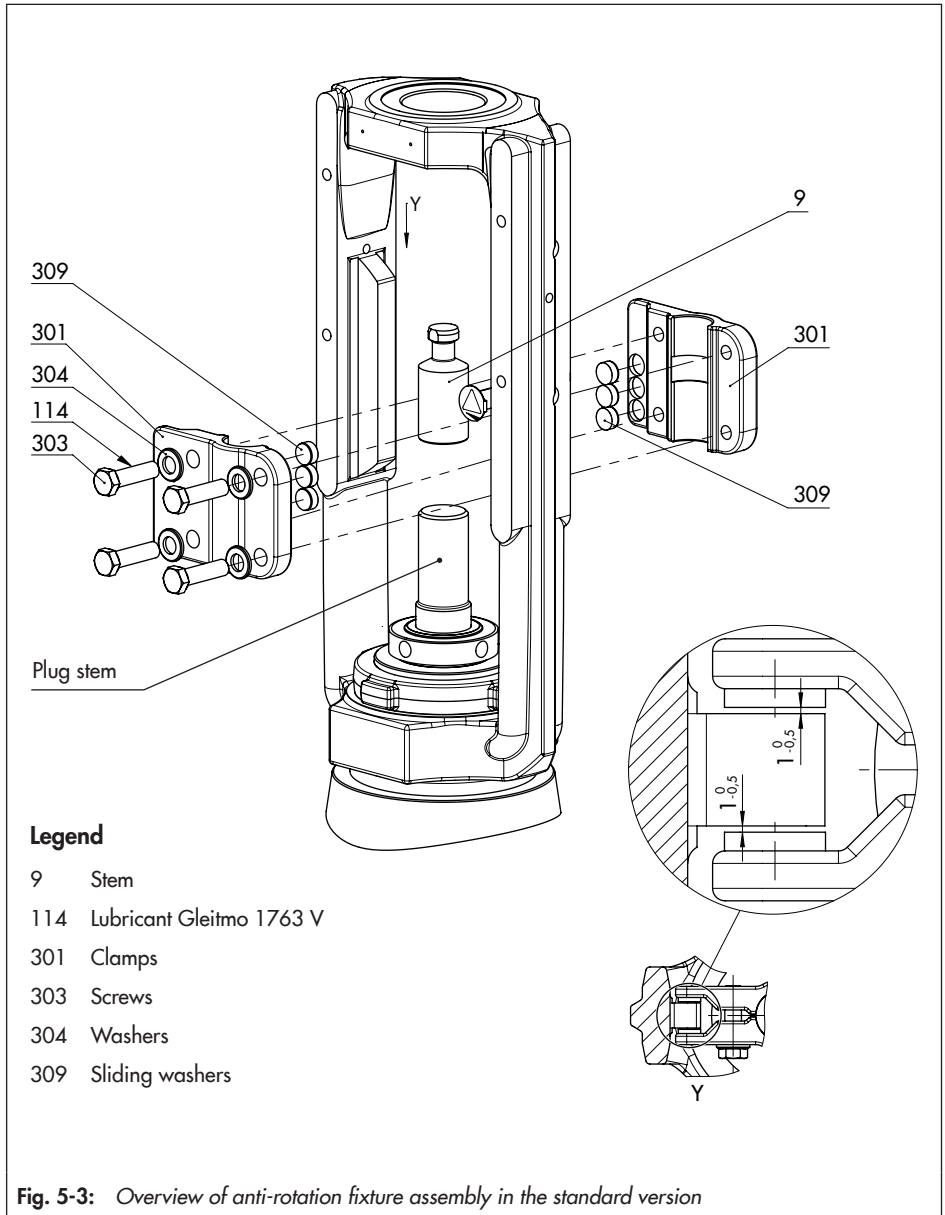

## b) Special version for nominal sizes NPS 2 to 4

See Fig. 5-2 and Fig. 5-6

### 1. Version with packing flange:

- i. Gradually unthread the two packing nuts (163) at the hex head in a criss-cross pattern.
- ii. Lift the two packing nuts (including disk springs when packing flange is loaded by external spring elements) as well as the packing flange (162) upward over the studs (164) off the valve bonnet (2/21).

### Version with centrally fastened packing:

Continue as described in step 2.

2. Fasten the travel indicator scale (84) with hanger (83) and warning label (255), if applicable, to the yoke (3) using the screws (82). While fastening it, position the travel indicator scale (84) on the hanger (83) according to Table 5-4.
3. Screw tight the holder (302) using the screws (306) and washers (308). Observe the tightening torques specified in Table 5-3.
4. Place the yoke (3) on the bonnet in such a way that the two holes on the top of the bonnet are aligned with the open sides of the yoke (see Fig. 5-4).
5. Fasten the yoke (3) using the castellated nut (92).

### 6. Version with packing flange:

- i. Place the packing flange (162) over the studs (164) of the valve bonnet (2/21) on the packing follower (8).
- ii. Thread the two packing nuts (163) (including disk springs when packing flange is loaded by external spring elements) onto the studs (164) and hand-tighten them. Guide the packing nuts (163) through the holes in the packing flange of the spring-loaded packing.

### Version with centrally fastened packing:

Continue as described in step 7.

7. Use a soft-faced hammer or lever press to press the sliding washers (309) (without using any lubricant) into the holes of the clamps (301) as far as they will go. Remove any excess material.
8. Apply a thin film of lubricant (114) to the threads of the stem (9) and screws (303).

---

### ! NOTICE

#### **Impaired functioning due to incorrectly applied lubricant.**

➔ *Do not apply any lubricant to the threads of the clamps (301) or the plug stem.*

---

9. Position the clamps (301) and stem (9) on the plug stem according to Table 5-4 and tighten screws (303) and washers (304) by hand.
10. Mount the actuator (see Chapter 5.3.2).
11. Thread the stem (9) upwards until the head of the stem rests on the extended actuator stem.

12. Retract the actuator stem to relieve the stem (9).
13. Gradually tighten the screws (303) in a crisscross pattern. Observe the tightening torques specified in Table 5-3.

**Table 5-3: Tightening torques**

Item	Screw size	Tightening torque [Nm]
306	M10	30
303	M8	15

14. Check and ensure the following:
  - There is a nominal clearance of 0.5 to 1 mm between the sliding washers and their contact surface on the yoke on each side (see detailed view Y in Fig. 5-6).
  - The anti-rotation fixture does not get stuck on the yoke and can move freely in the direction of travel.
15. Extend the actuator stem again and mount the stem connector clamps.

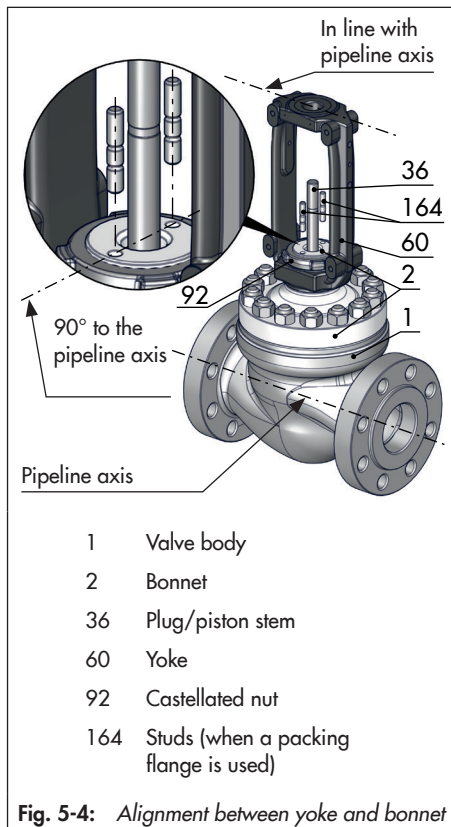

**Fig. 5-4: Alignment between yoke and bonnet**

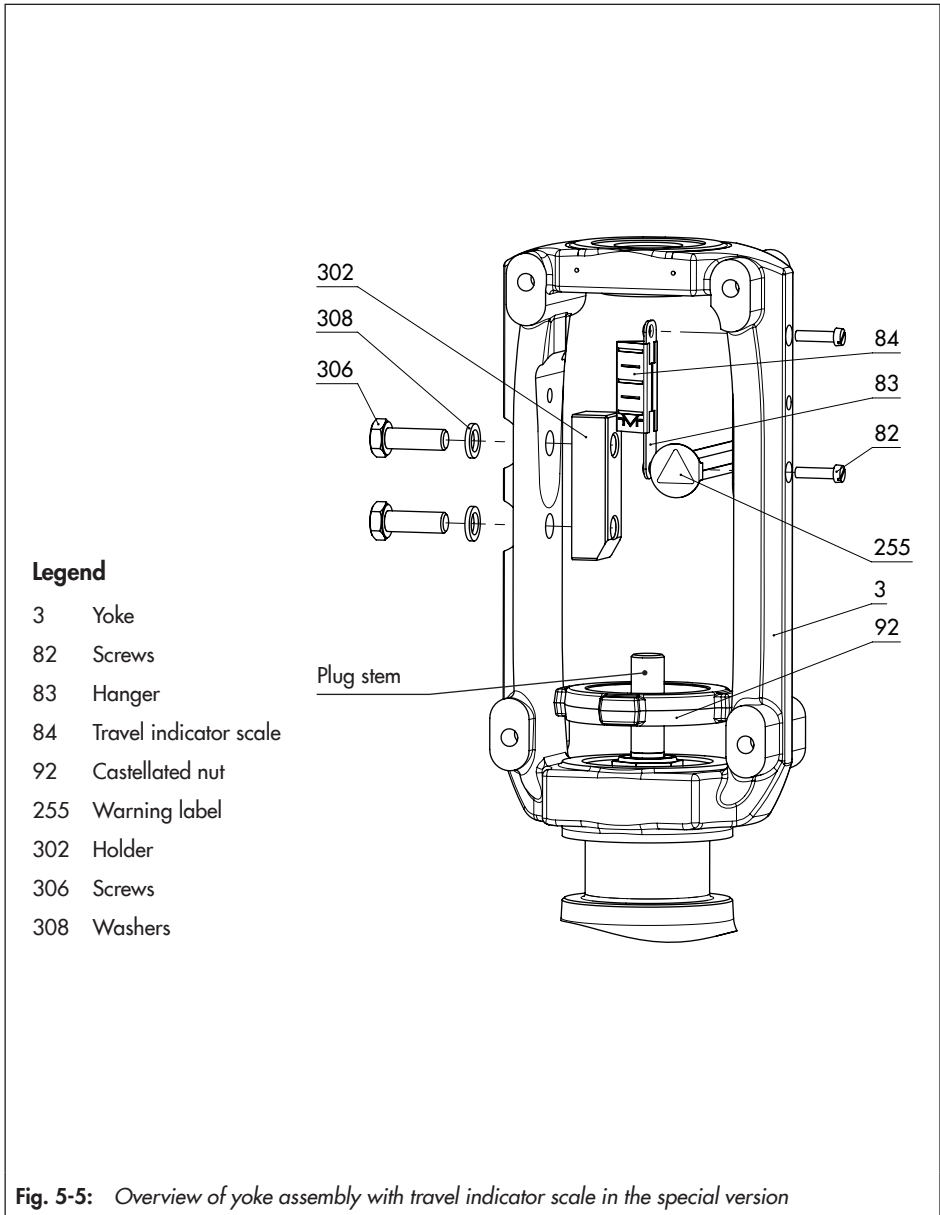
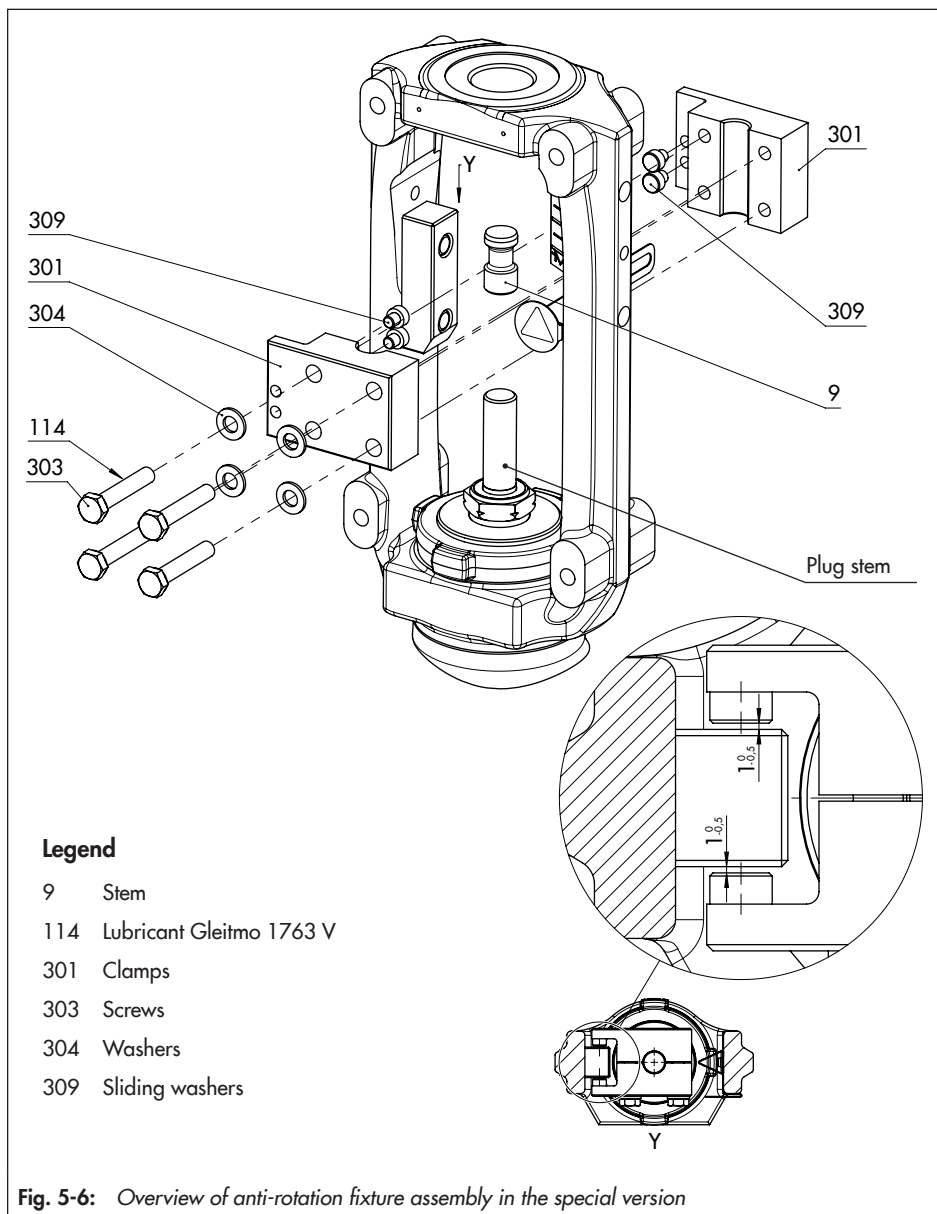

Fig. 5-5: Overview of yoke assembly with travel indicator scale in the special version



## Installation

**Table 5-4:** Mounting dimensions for Types 3271 and 3277 Pneumatic Actuators · See Fig. 5-7 for dimensional drawing

Actuator [cm <sup>2</sup> ]	Travel [mm]	Actuator preloading		Dimension when the valve is closed [mm]									
		[%]	[mm]	H <sub>F</sub>	H <sub>G</sub>	H <sub>I</sub>	H <sub>K</sub>	H <sub>L</sub>	H <sub>N</sub>	H <sub>O</sub>	H <sub>T</sub>		
<b>DN 50 to 100/NPS 2 to 4 · Special version</b>													
350	15	0	0	157	75	238	54	-	112	42	-		
	15	25	3.75	161	71								
355 750	15	50	15	157	75								
	15	75	22.5	164.5	67.5								
	30	0	0	142	90							80.5	30
	30	25	7.5	149.5	82.5							80.5	30
1000 1400-60	15	100	60	182	105			-	-				
	30	75	45	167	120								
1400-120	30	75	90	277	195								-
2800	30	100	120	277	195								
<b>DN 125 to 150/NPS 6 · Standard version</b>													
355 750	15	0	0	348.5	67.5			277	87	133	190	70	145
	15	50	15	341	75	145							
	15	75	22.5	348.5	67.5	145							
	30	0	0	326	90	120							
	30	25	7.5	333.5	82.5	120							
	1000 1400-60	15	100	60	311	105	103						
30		0	0	296	120	88							
30		75	45	296	120	88							
60		0	0	251	165	58							
60		25	15	266	150	58							
1400-120		15	87.5	105	321	180	148						105
	30	0	0	276	225	133	75						
	30	75	90	306	195		105						
	60	0	0	393	255	148	75						
	60	50	60	276	225	133	75						
	2800 5600	30	0	0	276		225			75			
30		100	120	306	195		105						
60		0	0	393	255		148			75			
60		75	90	276	225	133	75						



Actuator [cm <sup>2</sup> ]	Travel [mm]	Actuator preloading		Dimension when the valve is closed [mm]								
		[%]	[mm]	H <sub>F</sub>	H <sub>G</sub>	H <sub>I</sub>	H <sub>K</sub>	H <sub>L</sub>	H <sub>N</sub>	H <sub>O</sub>	H <sub>T</sub>	
<b>DN 200 to 250/NPS 8 to 10 up to seat bore 200 - Standard version</b>												
355 750	30	0	0	326	90	280	87	146	193	65	120	
1000 1400-60	30	0	0	296	120			151			83	
	30	75	45	296	120			151			83	
	60	0	0	251	165			137			55	
	60	25	15	266	150			137			55	
	15	87.5	105	321	180			146			115	
1400-120	30	0	0	276	225			133			76	
	30	75	90	306	195			146			100	
	60	0	0	393	255			146			185	
	60	50	60	276	225			133			76	
	30	0	0	276	225			133			76	
2800 5600	30	100	120	306	195			146			100	
	60	0	0	393	255			146			185	
	60	75	90	276	225			133			76	
	60	75	90	276	225			133			76	

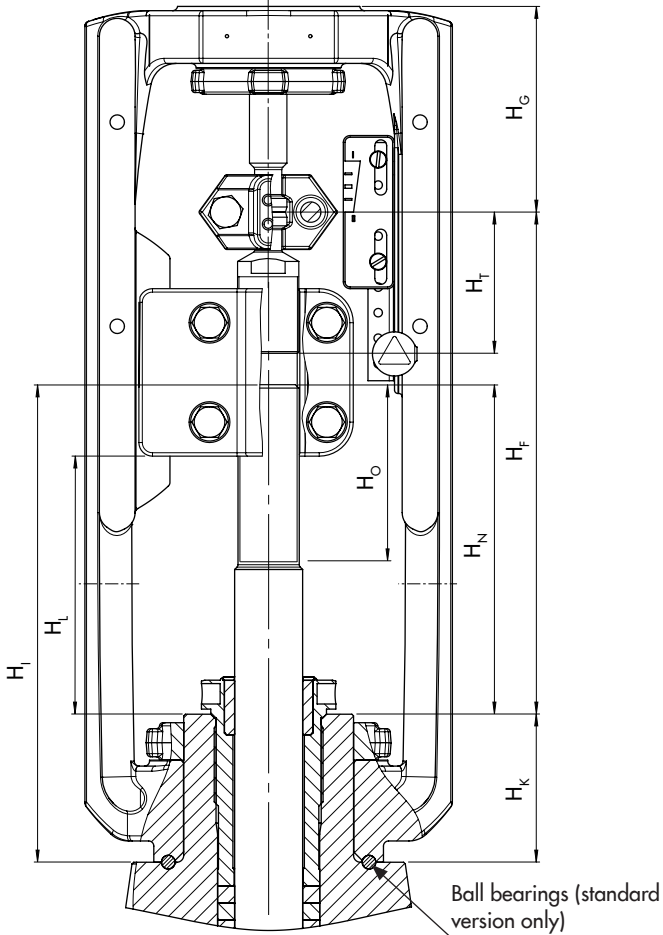

**Fig. 5-7:** Dimensional drawing with mounting dimensions for Types 3271 and 3277 Pneumatic Actuators

### 5.3.2 Mounting the actuator onto the valve

#### **⚠ WARNING**

#### **Risk of personal injury due to preloaded springs in pneumatic actuators.**

Valves in combination with pneumatic actuators with preloaded springs are under tension. These control valves with SAMSON pneumatic actuators can be identified by the long bolts protruding from the bottom of the actuator.

- Before starting any work on the actuator, which requires the actuator to be opened, or when the actuator stem has become blocked, relieve the compression from the preloaded springs (see associated actuator documentation).

#### **⚠ WARNING**

#### **Risk of personal injury due to incorrect removal of the anti-rotation fixture under tension.**

Once the actuator has been mounted on the valve and the assembly is ready for use, the clamps (301) of the anti-rotation fixture on the plug stem are under tension.

- Follow the instructions in this document during mounting or removal.
- Do not loosen the screws of the anti-rotation fixture while the force generated by the supply air and/or the actuator springs is transmitted to the actuator stem and the plug stem.

- Remove the actuator from the valve or otherwise ensure that it cannot transmit any forces to the actuator stem before removing the anti-rotation fixture from the plug stem.

Depending on the version, SAMSON control valves are either delivered with the actuator already mounted on the valve or the valve and actuator are delivered separately. When delivered separately, the valve and actuator must be assembled together on site.

#### **Versions with V-port plug**

To achieve the best flow conditions inside the valve, the V-port plug must always be installed with the port that releases the flow first when the valve opens facing toward the valve outlet. This is the largest of the three V-shaped ports (see Fig. 5-8).

- Before mounting the actuator, determine which V-shaped port is uncovered first when the plug is lifted out of the seat.
- On mounting the actuator, make sure that the V-shaped port uncovered first faces toward the valve outlet.

## Installation

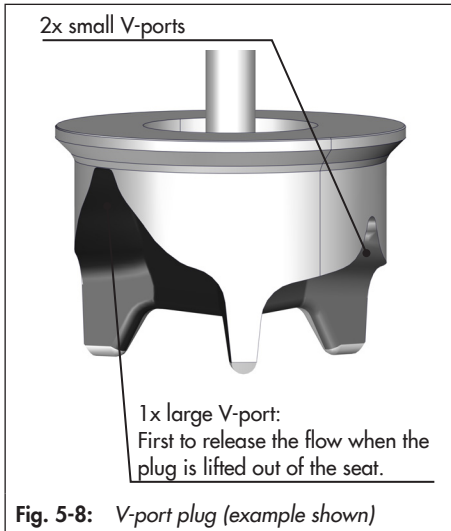

### **i** Note

*In contrast to the V-port plug, the parabolic plug does not need to be aligned in any special way.*

### Versions with perforated plug

Only one hole is located near the seal facing of perforated plugs with equal percentage characteristic. Depending on the nominal size, the hole pattern varies and is partly unsymmetrical. The process medium in the valve flows through the holes as soon as the plug is lifted out of the seat. To achieve the best flow conditions inside the valve, the perforated plug must always be installed with the hole that releases the flow first when the valve opens facing toward the valve outlet (see Fig. 5-9).

- Before mounting the actuator, check the hole pattern of the perforated plug and determine which hole is the closest to the seal facing and is uncovered first when the plug is lifted out of the seat.
- On mounting the actuator, make sure that the hole uncovered first faces toward the valve outlet.

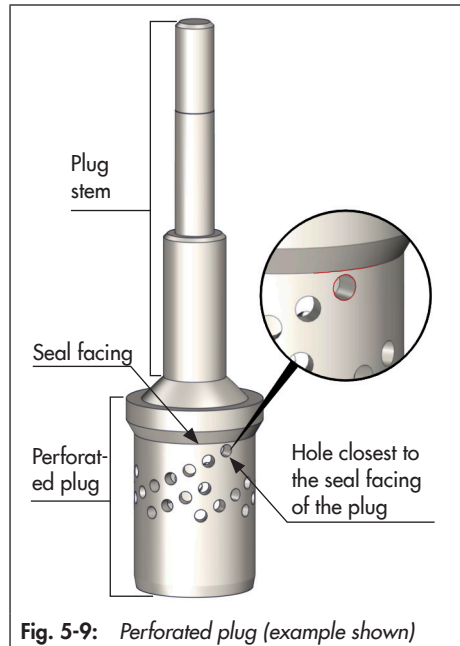

### a) Mounting the actuator

- To mount the actuator, proceed as described in the associated actuator documentation.

## b) Aligning the travel indicator scale

After mounting the actuator, the travel indicator scale must be aligned. To do so, align '0' on the travel indicator scale with the tip of the stem connector clamp (see Fig. 5-7).

1. Move the valve to the closed position.
2. Loosen the screws on the travel indicator scale.
3. Align the travel indicator scale.
4. Fix the travel indicator scale into place by tightening the screws.

## 5.4 Installing the valve into the pipeline

### NOTICE

**Premature wear and leakage due to insufficient support or suspension.**

→ Support or suspend the valve sufficiently at suitable points.

1. Close the shut-off valves in the pipeline at the inlet and outlet of the plant section while the valve is being installed.
2. Prepare the relevant section of the pipeline for installing the valve.
3. Remove the protective caps from the valve ports before installing the valve.
4. Lift the valve using suitable lifting equipment to the site of installation (see the 'Lifting the valve' chapter). Observe the flow direction through the valve. The ar-

row on the valve indicates the direction of flow.

5. Make sure that the correct flange gaskets are used.
6. Bolt the pipe to the valve free of stress.
7. Attach a support or suspension on the valve, if necessary.

## 5.5 Testing the installed valve

### ! DANGER

**Risk of bursting due to incorrect opening of pressurized equipment or components.**

Valves and pipelines are pressure equipment that may burst when handled incorrectly. Flying projectile fragments or the release of process medium under pressure can cause serious injury or even death.

Before starting any work on pressure-bearing or pressure-retaining parts belonging to the valve assembly:

- Depressurize all plant sections affected and the valve (including the actuator). Release any stored energy.
- Drain the process medium from the plant sections affected as well as from the valve.

### ! WARNING

**For valves with a bellows seal, there is a risk of personal injury due to pressurized components and as a result of process medium being discharged.**

- Do not loosen the screw on the test connection while the valve is pressurized.

---

### **⚠ WARNING**

**Risk of hearing loss or deafness due to loud noise.**

Noise emission (e.g. cavitation or flashing) may occur during operation caused by the process medium and the operating conditions. Additionally, a loud noise may briefly occur through the sudden venting of the pneumatic actuator or pneumatic valve accessories not fitted with noise-reducing elements. Both can damage hearing.

- Follow the standard operating procedures provided by the plant operator. In the event of a potential risk:
  - Wear hearing protection when working near the valve.

---

### **⚠ WARNING**

**Crush hazard arising from moving parts (actuator stem and plug/piston stem).**

- Do not insert hands or finger into the yoke while the air supply is connected to the actuator.
- Before working on the control valve, disconnect and lock the pneumatic air supply as well as the control signal.
- Do not impede the movement of the actuator stem and plug/piston stem by inserting objects into the yoke.
- Before unblocking the actuator stem and plug/piston stem after they have become blocked (e.g. due to seizing up after remaining in the same position for a long time), release any stored energy in the actuator (e.g. spring compression). See associated actuator documentation.

---

### **⚠ WARNING**

**Risk of personal injury due to exhaust air being vented or compressed air escaping from pneumatically operated components.**

While the valve is operating, air is vented from the actuator, e.g. to change the valve's position or to open or close the valve.

- Wear eye protection when working in close proximity to pneumatic fittings and in the danger zone of the vent openings.

---

### **⚠ WARNING**

**Risk of personal injury due to preloaded springs in pneumatic actuators.**

Valves in combination with pneumatic actuators with preloaded springs are under tension. These control valves with SAMSON pneumatic actuators can be identified by the long bolts protruding from the bottom of the actuator.

- Before starting any work on the actuator, which requires the actuator to be opened, or when the actuator stem has become blocked, relieve the compression from the preloaded springs (see associated actuator documentation).

To test the valve functioning before start-up or putting back the valve into operation, perform the following tests:

### 5.5.1 Leakage

The plant operator is responsible for performing the leak test and selecting the test method. The leak test must comply with the requirements of the national and international standards that apply at the site of installation.



#### Tip

*Our after-sales service can support you to plan and perform a leak test for your plant.*

---

1. Close the valve.
2. **Centrally fastened packing with threaded bushing:** Tighten threaded bushing (8) gradually applying the specified tightening torque.  
**Version with packing flange:** Gradually tighten the two packing nuts (163) on the packing flange (162) at the hex head in a crisscross pattern until the specified tightening torque is reached.
3. Slowly apply the test medium to the inlet space upstream of the valve. A sudden surge in pressure and resulting high flow velocities can damage the valve.
4. Open the valve.
5. Apply the required test pressure.
6. Check the valve for leakage to the atmosphere.

7. Depressurize the pipeline section and valve.
8. Rework any parts that leak (see section "Adjusting the packing") and repeat the leak test.

### Adjusting the packing

The sealing elements of the adjustable packing are compressed between the valve body and plug stem by applying a specified tightening torque. If the packing leaks, the threaded bushing or packing flange can be repeatedly tightened further by the specified tightening torque during the valve's service life until the sealing elements must be replaced.

Live-loaded packings are loaded by internal or external springs. Pre-loaded springs maintain a constant load on the sealing elements, which is automatically adjusted, even as the sealing elements wear down over time until they must be replaced. Once the specified tightening torque has been applied to the live-loaded packing during first start-up, additional tightening of the packing set is only permitted if the packing does not seal properly directly after tightening with the specified torque.

A label on the yoke indicates whether an adjustable packing is installed (see the 'Markings on the device' chapter).

### NOTICE

**Impaired valve functioning due to increased friction as a result of the threaded bushing or packing flange being tightened too far.**

→ Make sure that the plug/piston stem can still move smoothly after the threaded bushing or the packing nuts on the packing flange have been tightened.

### Centrally fastened packing with threaded bushing

See Fig. 5-10

1. Continue to gradually tighten the threaded bushing (8) ( $\frac{1}{8}$  turn at a time).
  2. Open and close the valve several times.
  3. Check the valve for leakage to the atmosphere.
  4. Repeat steps 1 and 2 until the packing completely seals the valve or (depending on the packing type) no further than the point at which the threaded bushing rests on the valve bonnet.
- If the adjustable packing does not seal properly, contact our after-sales service.

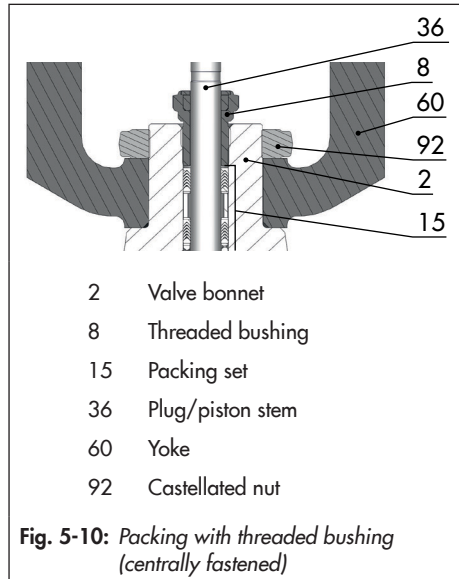

### Version with packing flange

See Fig. 5-11 and Fig. 5-12

1. Gradually tighten the two packing nuts (163) on the packing flange (162) at the hex head in a crisscross pattern ( $\frac{1}{8}$  turn at a time).
  2. Open and close the valve several times.
  3. Check the valve for leakage to the atmosphere.
  4. Repeat steps 1 and 2 until the packing completely seals the valve.
- If the adjustable packing does not seal properly, contact our after-sales service.



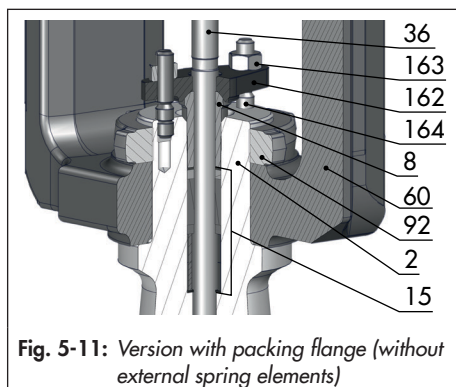

**Legend for Fig. 5-11 and Fig. 5-12**

- 2 Valve bonnet
- 8 Packing follower
- 15 Packing set
- 36 Plug/piston stem
- 60 Yoke
- 92 Castellated nut
- 162 Packing flange
- 163 Packing nut (including disk springs with packing flange loaded by external spring elements)
- 164 Stud

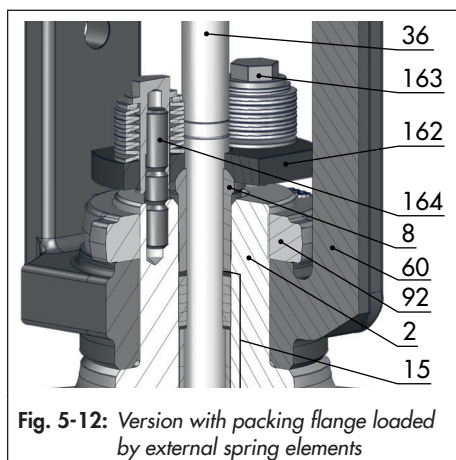

**5.5.2 Travel motion**

The movement of the actuator stem must be linear and smooth.

- ➔ Apply the maximum and minimum control signals to check the end positions of the valve. Open and close the valve, observing the movement of the actuator stem.
- ➔ Check the travel reading at the travel indicator scale.

### 5.5.3 Fail-safe position

The fail-safe position of a valve can only be checked when the valve is combined with an actuator that moves to the fail-safe position upon air supply or control signal failure.

#### **Fail-safe position with pneumatic actuators with integrated springs**

- Shut off the signal pressure line.
- Check whether the valve moves to the fail-safe position (see the 'Design and principle of operation' chapter).

### 5.5.4 Pressure test

The plant operator is responsible for performing the pressure test.



#### **Tip**

*Our after-sales service can support you to plan and perform a pressure test for your plant.*

---

During the pressure test, make sure the following conditions are met:

- Retract the plug/piston to open the valve.
- Observe the maximum permissible pressure for both the valve and plant.

## 6 Start-up

The work described in this chapter is to be performed only by personnel appropriately qualified to carry out such tasks.

### **⚠ WARNING**

#### **Risk of burn injuries due to hot or cold components and pipeline.**

Valve components and the pipeline may become very hot or cold. Risk of burn injuries.

- Follow the standard operating procedures provided by the plant operator. In the event of a potential risk:
  - Allow components and pipelines to cool down or warm up to the ambient temperature.
  - Wear protective clothing and safety gloves.

### **⚠ WARNING**

#### **For valves with a bellows seal, there is a risk of personal injury due to pressurized components and as a result of process medium being discharged.**

- Do not loosen the screw on the test connection while the valve is pressurized.

### **⚠ WARNING**

#### **Risk of hearing loss or deafness due to loud noise.**

Noise emission (e.g. cavitation or flashing) may occur during operation caused by the process medium and the operating conditions. Additionally, a loud noise may briefly occur through the sudden venting of the

pneumatic actuator or pneumatic valve accessories not fitted with noise-reducing elements. Both can damage hearing.

- Follow the standard operating procedures provided by the plant operator. In the event of a potential risk:
  - Wear hearing protection when working near the valve.

### **⚠ WARNING**

#### **Crush hazard arising from moving parts (actuator stem and plug/piston stem).**

- Do not insert hands or finger into the yoke while the air supply is connected to the actuator.
- Before working on the control valve, disconnect and lock the pneumatic air supply as well as the control signal.
- Do not impede the movement of the actuator stem and plug/piston stem by inserting objects into the yoke.
- Before unblocking the actuator stem and plug/piston stem after they have become blocked (e.g. due to seizing up after remaining in the same position for a long time), release any stored energy in the actuator (e.g. spring compression). See associated actuator documentation.

### **⚠ WARNING**

#### **Risk of personal injury due to exhaust air being vented or compressed air escaping from pneumatically operated components.**

While the valve is operating, air is vented from the actuator, e.g. to change the valve's position or to open or close the valve.

## Start-up

→ *Wear eye protection when working in close proximity to pneumatic fittings and in the danger zone of the vent openings.*

---

Before start-up or putting the valve back into service, make sure the following conditions are met:

- The control valve is properly installed in the pipeline (see the 'Installation' chapter).
- The leak and function tests have been completed successfully (see section 'Testing the installed valve' in the 'Installation' chapter).
- The prevailing conditions in the plant section concerned meet the valve sizing requirements (see section 'Intended use' in the 'Safety instructions and measures' chapter).

### **Start-up/putting the device back into operation**

1. Allow the valve to cool down or warm up to reach ambient temperature before start-up when the ambient temperature and process medium temperature differ greatly or the medium properties require such a measure.
2. Slowly open the shut-off valves in the pipeline. Slowly opening these valves prevents a sudden surge in pressure and high flow velocities which may damage the valve.
3. Check the valve to ensure it functions properly.

## 7 Operation

Immediately after completing start-up or putting the valve back into operation, the valve is ready for use.

### **⚠ WARNING**

**Risk of burn injuries due to hot or cold components and pipeline.**

Valve components and the pipeline may become very hot or cold. Risk of burn injuries.

- Follow the standard operating procedures provided by the plant operator.
- In the event of a potential risk:
  - Allow components and pipelines to cool down or warm up to the ambient temperature.
  - Wear protective clothing and safety gloves.

### **⚠ WARNING**

**For valves with a bellows seal, there is a risk of personal injury due to pressurized components and as a result of process medium being discharged.**

- Do not loosen the screw on the test connection while the valve is pressurized.

### **⚠ WARNING**

**Risk of hearing loss or deafness due to loud noise.**

Noise emission (e.g. cavitation or flashing) may occur during operation caused by the process medium and the operating conditions. Additionally, a loud noise may briefly occur through the sudden venting of the

pneumatic actuator or pneumatic valve accessories not fitted with noise-reducing elements. Both can damage hearing.

- Follow the standard operating procedures provided by the plant operator.
- In the event of a potential risk:
  - Wear hearing protection when working near the valve.

### **⚠ WARNING**

**Crush hazard arising from moving parts (actuator stem and plug/piston stem).**

- Do not insert hands or finger into the yoke while the air supply is connected to the actuator.
- Before working on the control valve, disconnect and lock the pneumatic air supply as well as the control signal.
- Do not impede the movement of the actuator stem and plug/piston stem by inserting objects into the yoke.
- Before unblocking the actuator stem and plug/piston stem after they have become blocked (e.g. due to seizing up after remaining in the same position for a long time), release any stored energy in the actuator (e.g. spring compression). See associated actuator documentation.

### **⚠ WARNING**

**Risk of personal injury due to exhaust air being vented or compressed air escaping from pneumatically operated components.**

While the valve is operating, air is vented from the actuator, e.g. to change the valve's position or to open or close the valve.

## Operation

→ *Wear eye protection when working in close proximity to pneumatic fittings and in the danger zone of the vent openings.*

---

### 7.1 Normal operation

#### Control valve with pneumatic actuator

The handwheel of valves with actuators fitted with a handwheel must be in the neutral position during normal operation.

### 7.2 Manual operation

#### Control valve with pneumatic actuator

Valves with actuators fitted with a handwheel can be manually closed or opened in the event of failure of the auxiliary energy supply.

## 8 Malfunctions

Read hazard statements, warnings and caution notes in the 'Safety instructions and measures' chapter.

### 8.1 Troubleshooting

Malfunction	Possible reasons	Recommended action
Actuator and plug/ piston stem does not move on demand.	Actuator is blocked.	Put the control valve out of operation (see the 'Decommissioning' chapter) and remove the blockage. <b>WARNING!</b> A blocked actuator or plug or piston stem (e.g. due to seizing up after remaining in the same position for a long time) can suddenly start to move uncontrollably. Injury to hands or fingers is possible if they are inserted into the actuator or valve. Before trying to unblock the actuator or plug or piston stem, disconnect and lock the air supply as well as the control signal. Before unblocking the actuator, release any stored energy in the actuator (e.g. spring compression). See associated actuator documentation.
	Diaphragm in the actuator defective	See associated actuator documentation.
	Signal pressure too low	Check the signal pressure. Check the signal pressure line for leakage.
Jolting movement of the actuator and plug or piston stem	Version with adjustable packing <sup>1)</sup> ; Packing tightened too far	Tighten the packing correctly (see section 'Adjusting the packing' in the 'Installation' chapter > 'Testing the installed valve').
Actuator and plug or piston stem do not stroke through the full range.	Signal pressure too low	Check the signal pressure. Check the signal pressure line for leakage.
	Travel stop active	See associated actuator documentation.
	Incorrect setting of valve accessories	Check the settings of the valve accessories.
Increased flow through closed valve (seat leakage)	Dirt or other foreign particles deposited between the seat and plug.	Shut off the section of the pipeline and flush the valve.
	Valve trim is worn out.	Replace valve trim (see the 'Servicing' chapter) or contact our after-sales service.

## Malfunctions

Malfunction	Possible reasons	Recommended action
The valve leaks to the atmosphere (fugitive emissions).	Defective packing	Replace packing (see the 'Servicing' chapter) or contact our after-sales service.
	Version with adjustable packing <sup>1)</sup> : Packing not tightened correctly	Adjust the packing (see section 'Adjusting the packing' in the 'Installation' chapter > 'Testing the installed valve'). Contact our after-sales service when it continues to leak.
	Version with bellows seal: The bellows seal is defective.	Contact our after-sales service.
	Flanged joint loose or body gaskets worn out	Check the flanged joint. Replace body gaskets (see the 'Servicing' chapter) or contact our after-sales service.

<sup>1)</sup> See the 'Markings on the device' chapter

### **i** Note

Contact our after-sales service for malfunctions not listed in the table.

## 8.2 Emergency action

Plant operators are responsible for emergency action to be taken in the plant.

In the event of a valve malfunction:

1. Close the shut-off valves upstream and downstream of the control valve to stop the process medium from flowing through the valve.
2. Perform troubleshooting (see Chapter 8.1).
3. Rectify those malfunctions that can be remedied following the information given in this document. Contact our after-sales service in all other cases.

### Putting the device back into operation after a malfunction

See the 'Start-up' chapter.



## 9 Servicing and conversion

The work described in this chapter is to be performed only by personnel appropriately qualified to carry out such tasks.

Only perform service or conversion work on valves which meet all the following conditions:

- The nominal size is  $\leq$ NPS 4.
- The valve does not have a bellows seal.
- The valve does not have a flow divider.
- The valve does not have a balanced plug.
- ➔ Contact our after-sales service for service or conversion work on all other valve versions.

The following documents are also required for servicing the valve:

- Mounting and operating instructions for the mounted actuator, for example:
  - ► EB 8310-X for Type 3271 and Type 3277 Pneumatic Actuators

### **⚠ DANGER**

**Risk of bursting due to incorrect opening of pressurized equipment or components.**

Valves and pipelines are pressure equipment that may burst when handled incorrectly.

Flying projectile fragments or the release of process medium under pressure can cause serious injury or even death.

Before starting any work on pressure-bearing or pressure-retaining parts belonging to the valve assembly:

- ➔ Depressurize all plant sections affected and the valve (including the actuator). Release any stored energy.
- ➔ Drain the process medium from the plant sections affected as well as from the valve.

### **⚠ WARNING**

**Risk of burn injuries due to hot or cold components and pipeline.**

Valve components and the pipeline may become very hot or cold. Risk of burn injuries.

- ➔ Follow the standard operating procedures provided by the plant operator. In the event of a potential risk:
  - ➔ Allow components and pipelines to cool down or warm up to the ambient temperature.
  - ➔ Wear protective clothing and safety gloves.

### **⚠ WARNING**

**For valves with a bellows seal, there is a risk of personal injury due to pressurized components and as a result of process medium being discharged.**

- ➔ Do not loosen the screw on the test connection while the valve is pressurized.

### **⚠ WARNING**

**Risk of hearing loss or deafness due to loud noise.**

Noise emission (e.g. cavitation or flashing) may occur during operation caused by the process medium and the operating condi-

tions. Additionally, a loud noise may briefly occur through the sudden venting of the pneumatic actuator or pneumatic valve accessories not fitted with noise-reducing elements. Both can damage hearing.

- Follow the standard operating procedures provided by the plant operator. In the event of a potential risk:
  - Wear hearing protection when working near the valve.

---

### **⚠ WARNING**

#### **Crush hazard arising from actuator and plug stem moving.**

- Do not insert hands or finger into the yoke while the air supply is connected to the actuator.
- Before working on the control valve, disconnect and lock the pneumatic air supply as well as the control signal.
- Do not impede the movement of the actuator and plug stem by inserting objects into the yoke.
- Before unblocking the actuator and plug stem after they have become blocked (e.g. due to seizing up after remaining in the same position for a long time), release any stored energy in the actuator (e.g. spring compression). See associated actuator documentation.

---

### **⚠ WARNING**

#### **Risk of personal injury due to exhaust air being vented or compressed air escaping from pneumatically operated components.**

While the valve is operating, air is vented from the actuator, e.g. to change the valve's position or to open or close the valve.

- Wear eye protection when working in close proximity to pneumatic fittings and in the danger zone of the vent openings.

---

### **⚠ WARNING**

#### **Risk of personal injury due to preloaded springs in pneumatic actuators.**

Valves in combination with pneumatic actuators with preloaded springs are under tension. These control valves with SAMSON pneumatic actuators can be identified by the long bolts protruding from the bottom of the actuator.

- Before starting any work on the actuator, which requires the actuator to be opened, or when the actuator stem has become blocked, relieve the compression from the preloaded springs (see associated actuator documentation).

---

### **⚠ WARNING**

#### **Risk of personal injury due to residual process medium in the valve.**

While working on the valve, residual medium can flow out of the valve and, depending on its properties, cause personal injury, e.g. (chemical) burns.

- Follow the standard operating procedures provided by the plant operator. In the event of a potential risk:
  - Wear protective clothing, safety gloves, respiratory protection and eye protection.

**! NOTICE**

**Risk of control valve damage due to over- or under-torquing.**

Observe the specified torques when tightening control valve components. Excessive tightening torques lead to parts wearing out more quickly. Parts that are too loose may cause leakage.

- Observe the specified tightening torques.

**! NOTICE**

**Risk of valve damage due to the use of unsuitable tools.**

- Only use tools approved by SAMSON.

**! NOTICE**

**Risk of valve damage due to the use of unsuitable lubricants.**

- Only use lubricants approved by SAMSON.

**i Note**

The control valve was checked by SAMSON before delivery.

- Certain test results certified by SAMSON lose their validity when the valve is

opened. Such testing includes seat leakage and leak tests.

- The product warranty becomes void if service or repair work not described in these instructions is performed without prior agreement by SAMSON's After-sales Service.
- Only use original spare parts by SAMSON, which comply with the original specifications.

## 9.1 Periodic testing

Depending on the operating conditions, check the valve at certain intervals to prevent possible failure before it can occur. Plant operators are responsible for drawing up an inspection and test plan.

**💡 Tip**

Our after-sales service can support you in drawing up an inspection and test plan for your plant.

## Servicing and conversion

SAMSON recommends the following inspections and tests:

Inspection and testing	Recommended action to be taken in the event of a negative result
Check the markings, labels and nameplates on the valve for their readability and completeness.	Immediately renew damaged, missing or incorrect nameplates or labels. Clean any inscriptions that are covered with dirt and are illegible.
<p>External leakage (fugitive emissions)<sup>1)</sup>: Inspect the control valve at the possible points of leakage to ensure there is no leakage (see Fig. 9-1).</p> <p>Versions with bellows seal: <b>WARNING!</b> Risk of personal injury due to pressurized components and as a result of process medium being discharged. Do not loosen the screw on the test connection while the valve is pressurized.</p>	<p>Check flanged joints (tightening torques).</p> <p>Replace the gaskets at the flanged joints. For this purpose, put the control valve out of operation (see the 'Decommissioning' chapter).</p> <p>Version with adjustable packing<sup>2)</sup>: Adjust the packing (see section 'Adjusting the packing' in the 'Installation' chapter &gt; 'Testing the installed valve') or replace the packing. To replace the packing, put the control valve out of operation (see the 'Decommissioning' chapter).</p> <p>If the bellows seal is defective, put the control valve out of operation (see the 'Decommissioning' chapter). To repair the bellows seal, contact our after-sales service (see the 'Repairs' chapter).</p>
Check the valve accessories to ensure they are mounted properly.	Tighten the connections of the valve accessories.
Check the valve for external damage that could impair the proper functioning of the control valve or even its safe operation.	Repair any damage immediately. If necessary, put the control valve out of operation (see the 'Decommissioning' chapter).
Seat leakage <sup>1)</sup> (see Fig. 9-1) (without testing to check that the leakage class requirements are met)	Shut off the section of the pipeline and flush the valve to remove any dirt and/or deposited foreign particles between the seat and plug.

Inspection and testing	Recommended action to be taken in the event of a negative result
<p>Check to ensure that the actuator and plug stems move smoothly.</p>	<p>Version with adjustable packing <sup>2)</sup>: Tighten the packing correctly (see section 'Adjusting the packing' in the 'Installation' chapter &gt; 'Testing the installed valve').</p>
	<p>If the actuator stem or plug stem is blocked, put the control valve out of operation (see the 'Decommissioning' chapter) and remove the blockage.  <b>WARNING!</b> A blocked actuator or plug stem (e.g. due to seizing up after remaining in the same position for a long time) can suddenly start to move uncontrollably. Injury to hands or fingers is possible if they are inserted into the actuator or valve.                      Before trying to unblock the actuator or plug stem, disconnect and lock the pneumatic air supply as well as the control signal. Before unblocking the actuator, release any stored energy in the actuator (e.g. spring compression). See associated actuator documentation.</p>
	<p>SAMSON recommends the use of positioners with integrated diagnostic firmware for valves used for on/off service. The partial stroke test included in this software helps prevent a shut-off valve normally in its end position from seizing up or getting jammed.</p>
<p>If possible, check the valve's fail-safe position by briefly interrupting the air supply.</p>	<p>Put the control valve out of operation (see the 'Decommissioning' chapter). Identify the cause for the malfunction and rectify it (see the 'Troubleshooting' chapter).</p>

1) EXPERTplus valve diagnostics can help identify external leakage at dynamic sealing systems as well as seat leakage in valve versions without balanced plugs while the valve is in use. EXPERTplus comes as standard in the digital positioners (Type 3730, TROVIS 3730, Type 3731, TROVIS 3793, TROVIS 3797).

2) See the 'Markings on the device' chapter

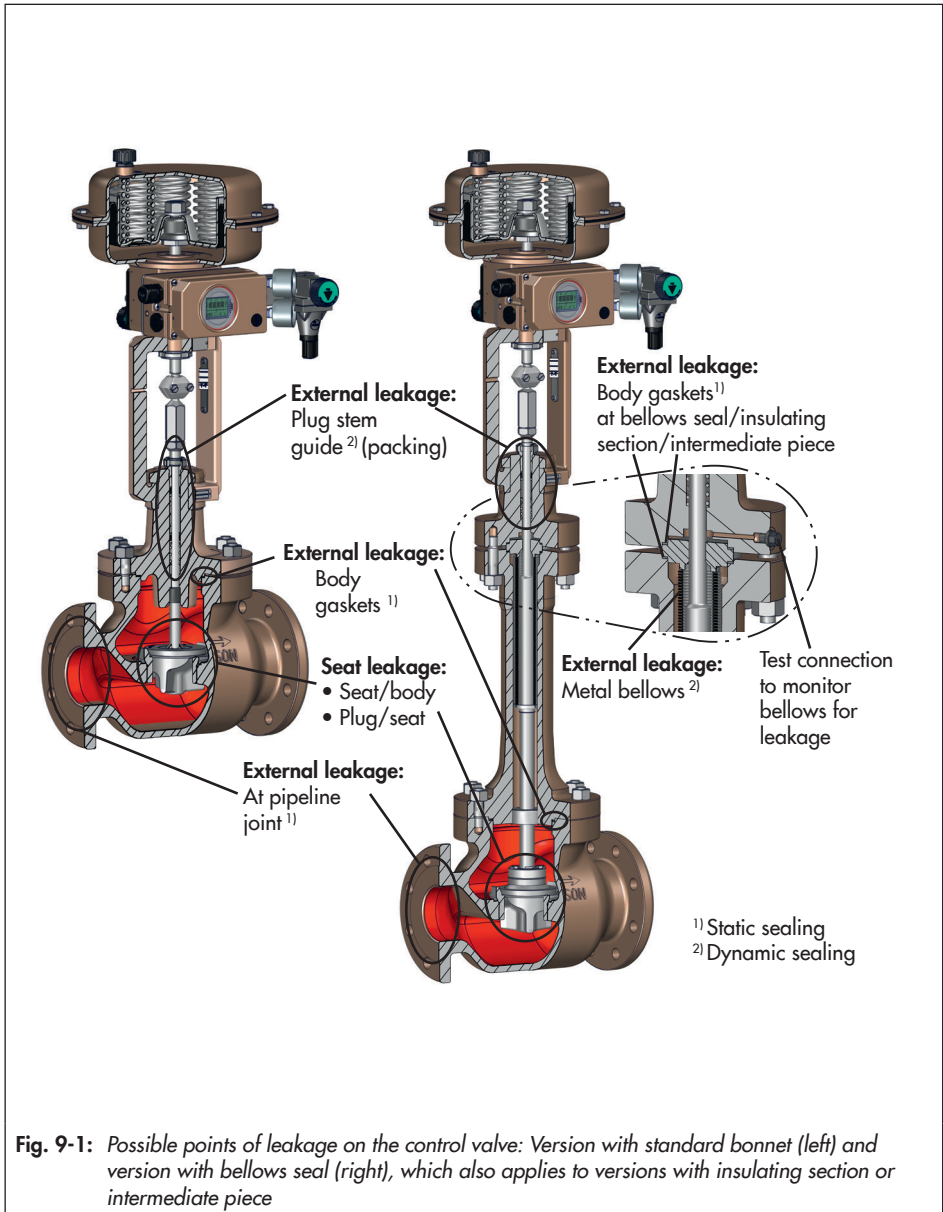

## 9.2 Preparation for servicing or conversion work

### **⚠ WARNING**

**Risk of personal injury due to incorrect removal of the anti-rotation fixture under tension.**

Once the actuator has been mounted on the valve and the assembly is ready for use, the clamps (301) of the anti-rotation fixture on the plug stem are under tension.

- Follow the instructions in this document during mounting or removal.
- Do not loosen the screws of the anti-rotation fixture while the force generated by the supply air and/or the actuator springs is transmitted to the actuator stem and the plug stem.
- Remove the actuator from the valve or otherwise ensure that it cannot transmit any forces to the actuator stem before removing the anti-rotation fixture from the plug stem.

1. Lay out the necessary material and tools to have them ready for the service work.
2. Put the control valve out of operation (see the 'Decommissioning' chapter).
3. Remove the actuator from the valve. See associated actuator documentation.

### **i Note**

To remove a pneumatic actuator with "stem extends" fail-safe action and/or with pre-loaded springs, a certain signal pressure must be applied to the actuator (see associated actuator documentation). Once the work is completed, the signal pressure must be removed and the air supply disconnected again and locked.

4. **Valve version without anti-rotation fixture:** Unscrew the stem connector nut (9) and lock nut (10) from the plug/piston stem (36).

#### **Valve version with anti-rotation fixture:**

Unscrew the stem connector clamps (301) and stem (9) from the plug/piston stem (36). Keep them together with the screws (303) and washers (304) in a safe place for later use.

### **💡 Tip**

SAMSON recommends removing the valve from the pipeline before performing any service work (see the 'Removal' chapter).

Once preparation is completed, the service work can be performed as described in the subchapters of Chapter 9.4.

### 9.3 Mounting the actuator on the valve after service and conversion work

1. **Valve version without anti-rotation fixture:** Loosely thread the lock nut (10) and stem connector nut (9) on the plug/piston stem (36).

**Valve version with anti-rotation fixture:**  
Apply a thin film of lubricant (114) to the threads of the stem (9) and screws (303).

---

#### ⚠ NOTICE

**Impaired functioning due to incorrectly applied lubricant.**

- Do not apply any lubricant to the threads of the clamps (301) or plug/piston stem.

---

Position the clamps (301) and stem (9) on the plug/piston stem according to the 'Mounting dimensions' table in the 'Installation' chapter (section 'Mounting the external anti-rotation fixture'). Fasten with screws (303) and washers (304). Hand-tighten the screws.

2. Mount actuator. See associated actuator documentation and the 'Installation' chapter.
3. Adjust lower or upper signal bench range (see associated actuator documentation).
4. If the valve has been removed, re-install the valve into the pipeline (see the 'Installation' chapter).
5. Put the control valve back into operation (see the 'Start-up' chapter). Observe the

requirements and conditions for start-up or putting the valve back into operation.

### 9.4 Service or conversion work

- Before performing any service or conversion work, preparations must be made to the control valve (see Chapter 9.2).
- After all service or conversion work is completed, check the control valve before putting it back into operation (see section 'Testing the installed valve' in the 'Installation' chapter).

---

#### ⚠ NOTICE

**Risk of control valve damage due to incorrect servicing or conversion.**

- Only perform service or conversion work on valves which meet all the following conditions:
- The nominal size is  $\leq$ NPS 4.
  - The valve does **not** have a bellows seal.
  - The valve does **not** have a flow divider.
  - The valve does **not** have a balanced plug.
- Contact our after-sales service for service or conversion work on all other valve versions.



## 9.4.1 Replacing gaskets in versions with standard bonnet (2) or insulating section (21)

### ⚠ NOTICE

**Risk of impaired valve functioning due to damaged parts.**

- Clean and check all the contact facings in the body and all other parts that come into contact with the gaskets to ensure they are free from damage before installing any new gaskets.
- Renew any parts with damaged facings or contact our after-sales service.

### a) Version with clamped-in seat and plug

1. Proceed as described in Chapter 9.4.3, section a) "Removing the (clamped-in) seat and plug"
2. Proceed as described in Chapter 9.4.3, section d) "Installing the (clamped-in) seat and plug"

### b) Version with screwed-in seat and plug

1. **Packing centrally fastened with threaded bushing:** Unscrew the threaded bushing (8) and pull it off the plug stem (36).

### Packing with packing flange:

- i. Gradually unthread the two packing nuts (163) at the hex head in a criss-cross pattern.
  - ii. Lift the two packing nuts (including disk springs when packing flange is loaded by external spring elements) as well as the packing flange (162) upward over the studs (164) off the valve bonnet (2/21).
  - iii. Pull out the packing follower (8).
2. Undo the body nuts (14) gradually in a crisscross pattern.
  3. Pull the valve bonnet (2/21) including yoke (60) upward off the plug stem (36) and lift out of the body (1).

If necessary, slightly press the plug stem (36) downward. This helps overcome the static friction between the packing (15) and plug stem (36) to ensure that the trim remains in the body (1).

4. Remove spiral gaskets (17, 126) from the body (1) or valve bonnet (2/21).
5. Pull the support element (63) upward out of the body (1). Use special tool for large nominal sizes.
6. Pull the plug (5) and plug stem (36) upward out of the body (1).
7. Use special tool to unscrew the retaining ring (221) and remove it from the body (1).
8. Remove seat (4) and spiral gasket (127) from the body (1).
9. Clean all parts that have been removed and the inside of the valve body (seating

## Servicing and conversion

surfaces of the gaskets) and check them to ensure that they are free from damage.

10. Insert a new spiral gasket (127) into the body (1) in the seat bridge area.
11. Place the seat (4) on the spiral gasket (127) in the body (1).
12. Screw in the retaining ring (221) to fasten down the seat (4) in the body (1). Use special tool and observe tightening torque.
13. Insert the plug (5) and plug stem (36) upright into the body (1) and center them on the seat (4).

**Version with V-port plug:** Align the plug (5), making sure that the largest V-shaped port of the V-port plug faces toward the valve outlet.

**Version with perforated plug:** Align the plug (5), making sure that the hole of the plug that releases the flow first faces toward the valve outlet.

See relevant section 'Mounting the actuator onto the valve' in the 'Installation' chapter.

14. Insert the support element (63) (including the pressed-in bushing (7)) upright over the plug stem (36) into the body (1) until it rests on the seating surface inside the body. Use special tool for large nominal sizes.
15. Place a new spiral gasket (126) on the support element (63).
16. Insert a new spiral gasket (17) into the body (1).

17. Place the valve bonnet (2/21) including yoke (60) from the top over the plug stem (36) on the body (1). Observe the alignment (see Fig. 9-4). The two boreholes on the top of the bonnet must be at a right angle to the pipeline axis.
18. Press the plug (5) firmly into the seat (4), while fastening down the valve bonnet (2/21) with the body nuts (14). Tighten the body nuts (14) gradually in a criss-cross pattern. Observe tightening torques.
19. Install the packing (see Chapter 9.4.2).



### Tip

*SAMSON recommends using new packing parts.*

---

## c) Version with cage and piston

1. Proceed as described in Chapter 9.4.3, section c) "Removing the cage and piston"
2. Proceed as described in Chapter 9.4.3, section f) "Installing the cage and piston"

## 9.4.2 Replacing the packing in versions with standard bonnet (2) or insulating section (21)

### a) Packing centrally fastened with threaded bushing

Different types of packing can be installed in the valve, which are centrally fastened with the threaded bushing. Refer to the documentation of the spare packing for the sequence and alignment of the packing parts as well as information on lubricants.

1. Unscrew the threaded bushing (8) and pull it off the plug/piston stem (36).
2. Undo the body nuts (14) gradually in a crisscross pattern.
3. Pull the valve bonnet (2/21) including yoke (60) upward off the plug/piston stem (36) and lift out of the body (1).  
If necessary, slightly press the plug/piston stem (36) downward. This helps overcome the static friction between the packing (15) and plug/piston stem (36) to ensure that the trim remains in the body (1).
4. Pull the entire packing out of the packing chamber using a suitable tool.
5. Clean the packing chamber thoroughly.
6. Use new packing parts (15) if they are worn or damaged.
7. Refer to the documentation of the spare packing for information on lubricants.

### Depending on packing version and application:

Apply a suitable lubricant to all the packing parts and to the plug/piston stem (36).

### Or if applicable:

Do not use any lubricant.

8. Insert the plug/piston (5) together with the plug/piston stem (36) and position them in the seat (4) in the closed position.

**Version with V-port plug:** Align the plug (5), making sure that the largest V-shaped part of the V-port plug faces toward the valve outlet.

**Version with perforated plug:** Align the plug (5), making sure that the hole of the plug that releases the flow first faces toward the valve outlet.

See relevant section 'Mounting the actuator onto the valve' in the 'Installation' chapter.

9. Place a new spiral gasket (17) on the valve body (1). Before inserting the gasket, clean the seating surface and check for damage.
10. Place a new spiral gasket (126) on the support element (63) or seat retainer (124). Before inserting the gasket, clean the seating surface and check for damage.
11. Place the valve bonnet (2/21) including yoke (60) from the top over the plug/piston stem (36) on the body (1). Observe the alignment (see Fig. 9-4). The two

## Servicing and conversion

boreholes on the top of the bonnet must be at a right angle to the pipeline axis.

12. Firmly press the plug/piston (5) into the seat (4), while fastening down the valve bonnet (2/21) with the body nuts (14). Tighten the body nuts (14) gradually in a crisscross pattern. Observe tightening torques.
13. Carefully slide the packing parts over the plug/piston stem (36) into the packing chamber using a suitable tool. Refer to the documentation of the spare packing for the correct sequence and alignment of the parts.
14. Screw in and hand-tighten threaded bushing (8).
15. Tighten threaded bushing (8) gradually applying the specified tightening torque.
16. If necessary, adjust the packing according to section 'Adjusting the packing' in the 'Installation' chapter > 'Testing the installed valve' > 'Leakage'.

### b) Version with packing flange (with or without external spring elements)

Different types of packing can be installed in the valve with packing flange. Refer to the documentation of the spare packing for the sequence and alignment of the packing parts as well as information on lubricants.

1. Gradually unthread the two packing nuts (163) at the hex head in a crisscross pattern.

2. Lift the two packing nuts (including disk springs when packing flange is loaded by external spring elements) as well as the packing flange (162) upward over the studs (164) off the valve bonnet (2/21).
3. Pull out the packing follower (8).
4. Undo the body nuts (14) gradually in a crisscross pattern.
5. Pull the valve bonnet (2/21) including yoke (60) upward off the plug/piston stem (36) and lift out of the body (1).  
If necessary, slightly press the plug/piston stem (36) downward. This helps overcome the static friction between the packing (15) and plug/piston stem (36) to ensure that the trim remains in the body (1).
6. Pull the entire packing out of the packing chamber using a suitable tool.
7. Clean the packing chamber thoroughly.
8. Use new packing parts (15) if they are worn or damaged.
9. Refer to the documentation of the spare packing for information on lubricants.

#### **Depending on packing version and application:**

Apply a suitable lubricant to all the packing parts and to the plug/piston stem (36).

#### **Or if applicable:**

Do not use any lubricant.

10. Insert the plug/piston (5) together with the plug/piston stem (36) and position

them in the seat (4) in the closed position.

**Version with V-port plug:** Align the plug (5), making sure that the largest V-shaped port of the V-port plug faces toward the valve outlet.

**Version with perforated plug:** Align the plug (5), making sure that the hole of the plug that releases the flow first faces toward the valve outlet.

See relevant section 'Mounting the actuator onto the valve' in the 'Installation' chapter.

11. Place a new spiral gasket (17) on the valve body (1). Before inserting the gasket, clean the seating surface and check for damage.
12. Place a new spiral gasket (126) on the support element (63) or seat retainer (124). Before inserting the gasket, clean the seating surface and check for damage.
13. Place the valve bonnet (2/21) including yoke (60) from the top over the plug/piston stem (36) on the body (1). Observe the alignment (see Fig. 9-4). The two boreholes on the top of the bonnet must be at a right angle to the pipeline axis.
14. Firmly press the plug/piston (5) into the seat (4), while fastening down the valve bonnet (2/21) with the body nuts (14). Tighten the body nuts (14) gradually in a crisscross pattern. Observe tightening torques.
15. Carefully slide the packing parts over the plug/piston stem (36) into the packing chamber using a suitable tool. Refer to the documentation of the spare packing for the correct sequence and alignment of the parts.
16. Insert packing follower (8).
17. Place the packing flange (162) over the studs (164) of the valve bonnet (2/21) on the packing follower (8).
18. Thread the two packing nuts (163) (including disk springs when packing flange is loaded by external spring elements) onto the studs (164) and hand-tighten them. Guide the packing nuts (163) through the holes in the packing flange of the spring-loaded packing.
19. Gradually tighten the two packing nuts (163) on the packing flange (162) at the hex head in a crisscross pattern until the specified tightening torque is reached.
20. If necessary, adjust the packing according to section 'Adjusting the packing' in the 'Installation' chapter > 'Testing the installed valve' > 'Leakage'.

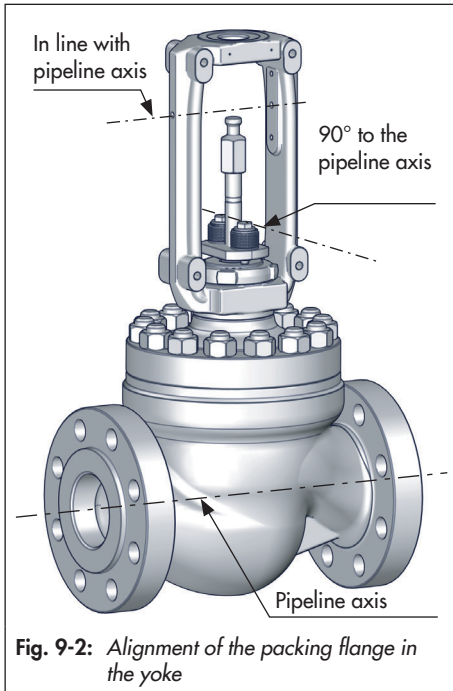

Fig. 9-2: Alignment of the packing flange in the yoke

### 9.4.3 Replacing the trim in versions with standard bonnet (2) or insulating section (21)

**NOTICE**

**Risk of damage to the facing of the seat and plug due to incorrect servicing.**

➔ Always replace both the seat and plug.

**Tip**

SAMSON recommends using new packing parts and gaskets when replacing the trim.

#### a) Removing the (clamped-in) seat and plug

1. **Packing centrally fastened with threaded bushing:** Unscrew the threaded bushing (8) and pull it off the plug stem (36).

##### Packing with packing flange:

- i. Gradually unthread the two packing nuts (163) at the hex head in a crisscross pattern.
  - ii. Lift the two packing nuts (including disk springs when packing flange is loaded by external spring elements) as well as the packing flange (162) upward over the studs (164) off the valve bonnet (2/21).
  - iii. Pull out the packing follower (8).
2. Undo the body nuts (14) gradually in a crisscross pattern.
  3. Pull the valve bonnet (2/21) including yoke (60) upward off the plug stem (36) and lift out of the body (1).

If necessary, slightly press the plug stem (36) downward. This helps overcome the static friction between the packing (15) and plug stem (36) to ensure that the trim remains in the body (1).

4. Pull all the packing parts out of the packing chamber in the valve bonnet (2/21) using a suitable tool.
5. Remove spiral gaskets (17, 126) from the body (1) or valve bonnet (2/21).
6. Pull the seat retainer (124) upward out of the body (1). Use special tool for large nominal sizes.

7. Pull the plug (5) and plug stem (36) upward out of the body (1).
8. Remove seat (4) and spiral gasket (127) from the body (1).

## b) Removing the (screwed-in) seat and plug

1. **Packing centrally fastened with threaded bushing:** Unscrew the threaded bushing (8) and pull it off the plug stem (36).

### Packing with packing flange:

- i. Gradually unthread the two packing nuts (163) at the hex head in a crisscross pattern.
  - ii. Lift the two packing nuts (including disk springs when packing flange is loaded by external spring elements) as well as the packing flange (162) upward over the studs (164) off the valve bonnet (2/21).
  - iii. Pull out the packing follower (8).
2. Undo the body nuts (14) gradually in a crisscross pattern.
  3. Pull the valve bonnet (2/21) including yoke (60) upward off the plug stem (36) and lift out of the body (1).

If necessary, slightly press the plug stem (36) downward. This helps overcome the static friction between the packing (15) and plug stem (36) to ensure that the trim remains in the body (1).

4. Pull all the packing parts out of the packing chamber in the valve bonnet (2/21) using a suitable tool.

5. Remove spiral gaskets (17, 126) from the body (1) or valve bonnet (2/21).
6. Pull the support element (63) upward out of the body (1). Use special tool for large nominal sizes.
7. Pull the plug (5) and plug stem (36) upward out of the body (1).
8. Use special tool to unscrew the retaining ring (221) and remove it from the body (1).
9. Remove seat (4) and spiral gasket (127) from the body (1).

## c) Removing the cage and piston

1. **Packing centrally fastened with threaded bushing:** Unscrew the threaded bushing (8) and pull it off the piston stem (36).

### Packing with packing flange:

- i. Gradually unthread the two packing nuts (163) at the hex head in a crisscross pattern.
  - ii. Lift the two packing nuts (including disk springs when packing flange is loaded by external spring elements) as well as the packing flange (162) upward over the studs (164) off the valve bonnet (2/21).
  - iii. Pull out the packing follower (8).
2. Undo the body nuts (14) gradually in a crisscross pattern.

## Servicing and conversion

3. Pull the valve bonnet (2/21) including yoke (60) upward off the piston stem (36) and lift out of the body (1).

If necessary, slightly press the piston stem (36) downward. This helps overcome the static friction between the packing (15) and piston stem (36) to ensure that the trim remains in the body (1).

4. Pull all the packing parts out of the packing chamber in the valve bonnet (2/21) using a suitable tool.
5. Remove spiral gaskets (17, 126) from the body (1), cylinder (463) or valve bonnet (2/21).
6. Remove cylinder (463) and seal (45) from the body (1). Use special tool for large nominal sizes.
7. Pull the piston (5) and piston stem (36) upward out of the cage (424) and remove from the body (1).
8. Remove the cage (424) from the body (1). Use special tool for large nominal sizes.
9. Remove seat (4) and spiral gasket (127) from the body (1).

### d) Installing the (clamped-in) seat and plug

1. Clean the inside of the valve body (seating surfaces of the gaskets) and check it to ensure that it is free from damage.
2. Clean the packing chamber in the valve bonnet (2/21) thoroughly.

3. Insert a new spiral gasket (127) into the body (1) in the seat bridge area.
4. Place the seat (4) on the spiral gasket (127) in the body (1).
5. Insert the plug (5) and plug stem (36) upright into the body (1) and center them on the seat (4).

**Version with V-port plug:** Align the plug (5), making sure that the largest V-shaped port of the V-port plug faces toward the valve outlet.

**Version with perforated plug:** Align the plug (5), making sure that the hole of the plug that releases the flow first faces toward the valve outlet.

See relevant section 'Mounting the actuator onto the valve' in the 'Installation' chapter.

6. Insert the seat retainer (124) (including pressed-in bushing (7)) upright over the plug stem (36) into the body (1) and center them on the seat (4). Use special tool for large nominal sizes. Align the openings of the seat retainer (124) symmetrically with the pipeline axis.
7. Place a new spiral gasket (126) on the seat retainer (124).
8. Insert a new spiral gasket (17) into the body (1).
9. Place the valve bonnet (2/21) including yoke (60) from the top over the plug stem (36) on the body (1). Observe the alignment (see Fig. 9-4). The two boreholes on the top of the bonnet must be at a right angle to the pipeline axis.



10. Press the plug (5) firmly into the seat (4), while fastening down the valve bonnet (2/21) with the body nuts (14). Tighten the body nuts (14) gradually in a criss-cross pattern. Observe tightening torques.
11. Install the packing (see Chapter 9.4.2)

### e) Installing the (screwed-in) seat and plug (≤NPS 6, ≤Class 600)

1. Clean the inside of the valve body (seating surfaces of the gaskets) and check it to ensure that it is free from damage.
2. Clean the packing chamber in the valve bonnet (2/21) thoroughly.
3. Insert a new spiral gasket (127) into the body (1) in the seat bridge area.
4. Place the seat (4) on the spiral gasket (127) in the body (1).
5. Screw in the retaining ring (221) to fasten down the seat (4) in the body (1). Use special tool and observe tightening torque.
6. Insert the plug (5) and plug stem (36) upright into the body (1) and center them on the seat (4).

**Version with V-port plug:** Align the plug (5), making sure that the largest V-shaped part of the V-port plug faces toward the valve outlet.

**Version with perforated plug:** Align the plug (5), making sure that the hole of the

plug that releases the flow first faces toward the valve outlet.

See relevant section 'Mounting the actuator onto the valve' in the 'Installation' chapter.

7. Insert the support element (63) (including the pressed-in bushing (7)) upright over the plug stem (36) into the body (1) until it rests on the seating surface inside the body. Use special tool for large nominal sizes.
8. Place a new spiral gasket (126) on the support element (63).
9. Insert a new spiral gasket (17) into the body (1).
10. Place the valve bonnet (2/21) including yoke (60) from the top over the plug stem (36) on the body (1). Observe the alignment (see Fig. 9-4). The two boreholes on the top of the bonnet must be at a right angle to the pipeline axis.
11. Press the plug (5) firmly into the seat (4), while fastening down the valve bonnet (2/21) with the body nuts (14). Tighten the body nuts (14) gradually in a criss-cross pattern. Observe tightening torques.
12. Install the packing (see Chapter 9.4.2)

## f) Installing the cage and piston

### ! NOTICE

#### **Risk of valve damage due to poor flow conditions.**

*The cage in the cage version can be manufactured with openings of varying size. The process medium in the valve flows through the opening as soon as the piston is lifted upward in the cage.*

→ *To achieve the best flow conditions inside the valve, install the cage with the largest opening facing toward the valve outlet.*

1. Clean the inside of the valve body (seating surfaces of the gaskets) and check it to ensure that it is free from damage.
2. Clean the packing chamber in the valve bonnet (2/21) thoroughly.
3. Insert a new spiral gasket (127) into the body (1) in the seat bridge area.
4. Place the seat (4) on the spiral gasket (127) in the body (1).
5. Insert the cage (424) into the body (1) and position it on the seat (4), while aligning the cage (424) within the valve body to ensure that the largest opening faces toward the valve outlet.
6. Insert the piston (5) together with the piston stem (36) upright through the cage (424) into the valve body (1) and position on the seat (4).
7. Place a new seal (45) on the cylinder (463). Make sure the seal is properly aligned (see Fig. 9-3).
8. Place the cylinder (463) together with the seal (45) over the piston stem (36) on the cage (424).
9. Place a new spiral gasket (126) on the cylinder (463).
10. Insert a new spiral gasket (17) into the body (1).
11. Place the valve bonnet (2/21) including yoke (60) from the top over the piston stem (36) on the body (1). Observe the alignment (see Fig. 9-4). The two boreholes on the top of the bonnet must be at a right angle to the pipeline axis.
12. Press the piston (5) firmly into the seat (4), while fastening down the valve bonnet (2/21) with the body nuts (14). Tighten the body nuts (14) gradually in a crisscross pattern. Observe tightening torques.
13. Install the packing (see Chapter 9.4.2)

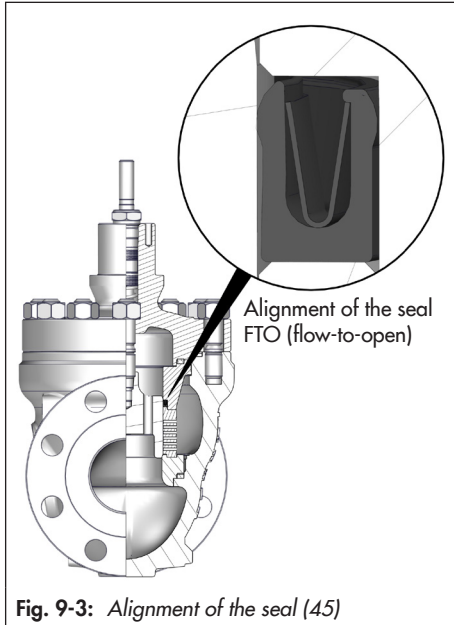

**Fig. 9-3:** Alignment of the seal (45)

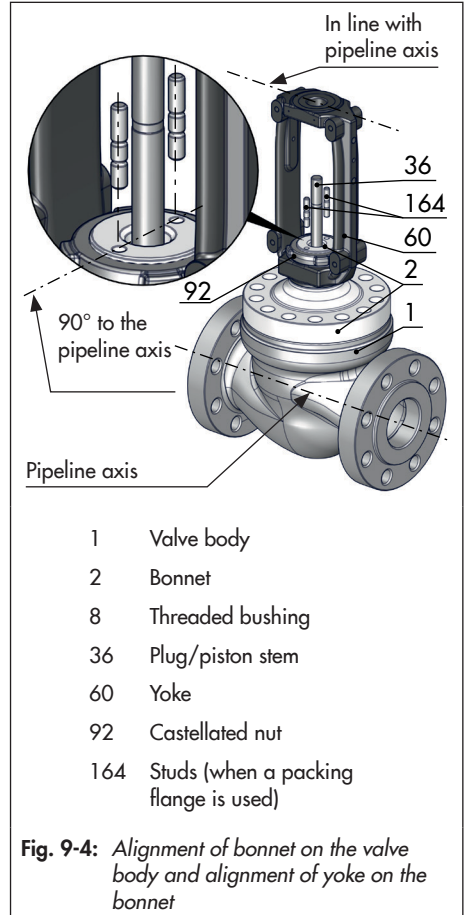
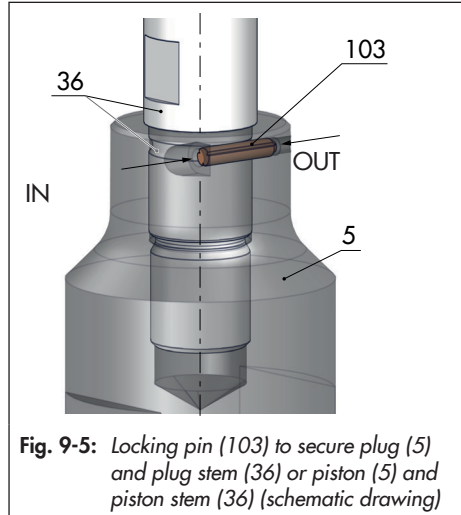

**Fig. 9-4:** Alignment of bonnet on the valve body and alignment of yoke on the bonnet

### 9.4.4 Replacing the plug/ piston on the plug/ piston stem

The plug/piston and plug/piston stem are fastened together. To prevent the plug/piston from becoming unintentionally detached from the plug/piston stem, the connection is additionally secured by a tangentially inserted pin (see Fig. 9-5). To replace the plug/piston, proceed as follows:

1. Firmly clamp the plug/piston (5) into a vise.
2. Use a suitable tool (mandrel) to drive the locking pin (103) out of the plug or piston in the "OUT" direction (see Fig. 9-5).
3. Unscrew the plug/piston stem (36) from the plug or piston (5) using a suitable tool.
4. Dispose of the worn plug or piston.
5. Firmly clamp the new plug/piston (5) into a vise using protective jaws. Make sure that the plug/piston is not damaged by the vise.
6. Screw the plug/piston stem (36) into the plug or piston (5) and tighten using a suitable tool. Observe tightening torque.
7. Insert a new locking pin (103) into the hole in the plug or piston in the "IN" direction. Use a suitable tool (mandrel) to drive the pin in as far as it will go.
8. Slightly close the hole on the "IN" side by pressing it with a suitable tool to prevent the pin from moving unintentionally and falling out while the valve is operating.



**Fig. 9-5:** Locking pin (103) to secure plug (5) and plug stem (36) or piston (5) and piston stem (36) (schematic drawing)

## 9.5 Ordering spare parts and operating supplies

Contact your nearest SAMSON subsidiary or SAMSON's After-sales Service for information on spare parts, lubricants and tools.

### **Spare parts**

See the Appendix for details on spare parts.

### **Lubricants**

See the Appendix for details on suitable lubricants.

### **Tools**

See the Appendix for details on suitable tools.



## 10 Decommissioning

The work described in this chapter is to be performed only by personnel appropriately qualified to carry out such tasks.

### **⚠ DANGER**

**Risk of bursting due to incorrect opening of pressurized equipment or components.**

Valves and pipelines are pressure equipment that may burst when handled incorrectly.

Flying projectile fragments or the release of process medium under pressure can cause serious injury or even death.

Before starting any work on pressure-bearing or pressure-retaining parts belonging to the valve assembly:

- Depressurize all plant sections affected and the valve (including the actuator). Release any stored energy.
- Drain the process medium from the plant sections affected as well as from the valve.

### **⚠ WARNING**

**Risk of burn injuries due to hot or cold components and pipeline.**

Valve components and the pipeline may become very hot or cold. Risk of burn injuries.

- Follow the standard operating procedures provided by the plant operator.  
In the event of a potential risk:
  - Allow components and pipelines to cool down or warm up to the ambient temperature.
  - Wear protective clothing and safety gloves.

### **⚠ WARNING**

**For valves with a bellows seal, there is a risk of personal injury due to pressurized components and as a result of process medium being discharged.**

- Do not loosen the screw on the test connection while the valve is pressurized.

### **⚠ WARNING**

**Risk of hearing loss or deafness due to loud noise.**

Noise emission (e.g. cavitation or flashing) may occur during operation caused by the process medium and the operating conditions. Additionally, a loud noise may briefly occur through the sudden venting of the pneumatic actuator or pneumatic valve accessories not fitted with noise-reducing elements. Both can damage hearing.

- Follow the standard operating procedures provided by the plant operator.  
In the event of a potential risk:
  - Wear hearing protection when working near the valve.

### **⚠ WARNING**

**Crush hazard arising from moving parts (actuator stem and plug/piston stem).**

- Do not insert hands or finger into the yoke while the air supply is connected to the actuator.
- Before working on the control valve, disconnect and lock the pneumatic air supply as well as the control signal.

## Decommissioning

- Do not impede the movement of the actuator stem and plug/piston stem by inserting objects into the yoke.
  - Before unblocking the actuator stem and plug/piston stem after they have become blocked (e.g. due to seizing up after remaining in the same position for a long time), release any stored energy in the actuator (e.g. spring compression). See associated actuator documentation.
- 

### WARNING

#### **Risk of personal injury due to exhaust air being vented or compressed air escaping from pneumatically operated components.**

While the valve is operating, air is vented from the actuator, e.g. to change the valve's position or to open or close the valve.

- Wear eye protection when working in close proximity to pneumatic fittings and in the danger zone of the vent openings.
- 

### WARNING

#### **Risk of personal injury due to residual process medium in the valve.**

While working on the valve, residual medium can flow out of the valve and, depending on its properties, cause personal injury, e.g. (chemical) burns.

- Follow the standard operating procedures provided by the plant operator. In the event of a potential risk:
    - Wear protective clothing, safety gloves, respiratory protection and eye protection.
- 

To decommission the control valve for service work or to remove it from the pipeline, proceed as follows:

1. Close the shut-off valves upstream and downstream of the control valve to stop the process medium from flowing through the valve.
2. Completely drain the pipelines and valve.
3. Disconnect and lock the pneumatic air supply to depressurize the actuator.
4. Release any stored energy.
5. If necessary, allow the pipeline and valve components to cool down or warm up to the ambient temperature.



## 11 Removal

The work described in this chapter is to be performed only by personnel appropriately qualified to carry out such tasks.

### **⚠ WARNING**

**Risk of burn injuries due to hot or cold components and pipeline.**

Valve components and the pipeline may become very hot or cold. Risk of burn injuries.

- Follow the standard operating procedures provided by the plant operator.  
In the event of a potential risk:
  - Allow components and pipelines to cool down or warm up to the ambient temperature.
  - Wear protective clothing and safety gloves.

### **⚠ WARNING**

**Crush hazard arising from moving parts (actuator stem and plug/piston stem).**

- Do not insert hands or finger into the yoke while the air supply is connected to the actuator.
- Before working on the control valve, disconnect and lock the pneumatic air supply as well as the control signal.
- Do not impede the movement of the actuator stem and plug/piston stem by inserting objects into the yoke.
- Before unblocking the actuator stem and plug/piston stem after they have become blocked (e.g. due to seizing up after remaining in the same position for a long time), release any stored energy in the

actuator (e.g. spring compression). See associated actuator documentation.

### **⚠ WARNING**

**Risk of personal injury due to residual process medium in the valve.**

While working on the valve, residual medium can flow out of the valve and, depending on its properties, cause personal injury, e.g. (chemical) burns.

- Follow the standard operating procedures provided by the plant operator.  
In the event of a potential risk:
  - Wear protective clothing, safety gloves, respiratory protection and eye protection.

### **⚠ WARNING**

**Risk of personal injury due to preloaded springs in pneumatic actuators.**

Valves in combination with pneumatic actuators with preloaded springs are under tension. These control valves with SAMSON pneumatic actuators can be identified by the long bolts protruding from the bottom of the actuator.

- Before starting any work on the actuator, which requires the actuator to be opened, or when the actuator stem has become blocked, relieve the compression from the preloaded springs (see associated actuator documentation).

---

### **⚠ WARNING**

***Risk of personal injury due to incorrect removal of the anti-rotation fixture under tension.***

*Once the actuator has been mounted on the valve and the assembly is ready for use, the clamps of the anti-rotation fixture on the plug stem are under tension.*

- Do not loosen the screws of the anti-rotation fixture while the force generated by the supply air and/or the actuator springs is transmitted to the actuator stem and the plug stem.*
  - Remove the actuator from the valve or otherwise ensure that it cannot transmit any forces to the actuator stem before removing the anti-rotation fixture from the plug stem.*
- 

Before removing the valve, make sure the following conditions are met:

- The control valve is put out of operation (see the 'Decommissioning' chapter).

## **11.1 Removing the valve from the pipeline**

1. Support the valve to hold it in place when separated from the pipeline (see the 'Shipment and on-site transport' chapter).
2. Unbolt the flanged joint.
3. Remove the valve from the pipeline (see the 'Shipment and on-site transport' chapter).

## **11.2 Removing the actuator from the valve**

See associated actuator documentation.

## 12 Repairs

If the valve does not function properly according to how it was originally sized or does not function at all, it is defective and must be repaired or exchanged.

### ! NOTICE

**Risk of valve damage due to incorrect service or repair work.**

- ➔ Do not perform any repair work on your own.
- ➔ Contact SAMSON's After-sales Service for service and repair work.

### 12.1 Returning devices to SAMSON

Defective devices can be returned to SAMSON for repair.

Proceed as follows to return devices:

1. Exceptions apply concerning some special device models
  - ▶ [www.samsongroup.com](http://www.samsongroup.com) > Service > After-sales Service > Returning goods.
2. Send an e-mail
  - ▶ [returns-de@samsongroup.com](mailto:returns-de@samsongroup.com) to register the return shipment including the following information:
    - Type
    - Article number
    - Configuration ID
    - Original order

- Completed Declaration on Contamination, which can be downloaded from our website at
  - ▶ [www.samsongroup.com](http://www.samsongroup.com) > Service > After-sales Service > Returning goods.

**After checking your registration, we will send you a return merchandise authorization (RMA).**

3. Attach the RMA (together with the Declaration on Decontamination) to the outside of your shipment so that the documents are clearly visible.
4. Send the shipment to the address given on the RMA.

### i Note

*Further information on returned devices and how they are handled can be found at*

- ▶ [www.samsongroup.com](http://www.samsongroup.com) > Service > After-sales Service.



## 13 Disposal

SAMSON is a producer registered in Europe.

► <https://www.samsongroup.com> >

About SAMSON > Environment, Social & Governance > Material Compliance > Waste electrical and electronic equipment (WEEE)

WEEE reg. no.: DE 62194439



- Observe local, national and international refuse regulations.
- Do not dispose of components, lubricants and hazardous substances together with your household waste.

---

### **i** Note

SAMSON can provide you with a recycling passport according to PAS 1049 on request. Simply e-mail us at [aftersaleservice@samsongroup.com](mailto:aftersaleservice@samsongroup.com) giving details of your company address.

---

### Tip

On request, SAMSON can appoint a service provider to dismantle and recycle the product as part of a distributor take-back scheme.

---



## 14 Certificates

These declarations are included on the next pages:

- Declaration of conformity in compliance with Pressure Equipment Directive 2014/68/EU on page 14-2
- Declaration of conformity in compliance with Machinery Directive 2006/42/EC for Types 251GR-1 and 251GR-7 Pneumatic Control Valves on page 14-3
- Declaration of incorporation in compliance with Machinery Directive 2006/42/EC for the Type 251GR Valve with other actuators other than the actuators listed in the declaration of conformity according to the Machinery Directive 2006/42/EC for the control valves on page 14-4

The certificates shown were up to date at the time of publishing. The latest certificates can be found on our website:

► [www.samsongroup.com](http://www.samsongroup.com) > *Products* > *251GR*

Other optional certificates are available on request.

# EU DECLARATION OF CONFORMITY TRANSLATION



## Module H / N° CE-0062-PED-H-SAM 001-22-DEU-rev-A

For the following products, SAMSON hereby declares under its sole responsibility:

Devices	Series	Type	Version
Globe valve	240	3241	EN, body of gray cast iron from DN 150, body of spheroidal-graphite iron, from DN 100, fluids G2, L1, L2 <sup>1)</sup> EN/ANSI, body of steel, etc., all fluids
Three-way valve	240	3244	EN, body of gray cast iron from DN 150, body of spheroidal-graphite iron, from DN 100, fluids G2, L1, L2 <sup>1)</sup> EN/ANSI, body of steel, etc., all fluids
Cryogenic valve	240	3248	EN/ANSI, all fluids
Globe valve	250	3251	EN/ANSI, all fluids
Globe valve	250	3251-E	EN/ANSI, all fluids
Three-way valve	250	3253	EN/ANSI, body of steel, etc., all fluids
Globe valve	250	3254	EN/ANSI, all fluids
Angle valve	250	3256	EN/ANSI, all fluids
Split-body valve	250	3258	EN, all fluids
Angle valve (IG standards)	250	3259	EN, all fluids
Globe valve	V2001	3321	EN, body of steel, etc., all fluids ANSI, all fluids
Three-way valve	V2001	3323	EN, body of steel, etc., all fluids ANSI, all fluids
Angle seat valve	---	3353	EN, body of steel, etc., all fluids
Silencer	3381	3381-1	EN/ANSI, single attenuation plate with welding ends, all fluids
		3381-3	EN/ANSI, all fluids
		3381-4	EN/ANSI, single attenuation plate multi-stage with welding ends, all fluids
Globe valve	240	3241	ANSI, body of gray cast iron, Class 125, from NPS 5, fluids G2, L1, L2 <sup>1)</sup>
Cryogenic valve	240	3246	EN/ANSI, all fluids
Three-way valve	250	3253	EN, body of gray cast iron from DN200 PN16, fluids G2, L1, L2 <sup>1)</sup>
Globe valve	290	3291	ANSI, all fluids
Angle valve	290	3296	ANSI, all fluids
Cryogenic valve	---	3588	ANSI, up to NPS 6, Class 600, all fluids
Globe valve	590	3591	ANSI, all fluids
Angle valve	590	3596	ANSI, all fluids
Cryogenic valve	590	3598	ANSI, NPS 3 to NPS 8, Class 900, all fluids
Control valve	590	3595	ANSI, all fluids
Globe valve	SMS	241GR	EN/ANSI, all fluids
Globe valve	SMS	251GR	EN/ANSI, all fluids

<sup>1)</sup> Gases according to Article 4(1)(c.i), second indent  
Liquids according to Article 4(1)(c.ii)

that the products mentioned above comply with the requirements of the following standards:

Directive of the European Parliament and of the Council on the harmonization of the laws of the Member States relating to the making available on the market of pressure equipment	2014/68/EU	of 15 May 2014
Applied conformity assessment procedure for fluids according to Article 4(1)	Module H	Certificate-No.: N°CE-0062-PED-H-SAM 001-22-DEU-rev-A by Bureau Veritas 0062

The manufacturer's quality management system is monitored by the following notified body:

Bureau Veritas Services SAS, 4 place des Saisons, 92400 Courbevoie, France  
Applied harmonised standards and technical specifications: EN 12516-2, EN 12516-3, EN 12266-1, ASME B16.34

Manufacturer: SAMSON AKTIENGESELLSCHAFT, Weismüllerstrasse 3, 60314 Frankfurt am Main, Germany

Frankfurt am Main, August 6, 2024

*Andreas Wiedl*

Dr. Andreas Wiedl  
Chief Executive Officer (CEO)

*i.v. Sebastian Krause*

Sebastian Krause  
Vice President Product Development

Revision 12

Classification: Public · SAMSON AKTIENGESELLSCHAFT · Weismüllerstrasse 3 · 60314 Frankfurt am Main, Germany

Page 1 of 1



EU DECLARATION OF CONFORMITY  
TRANSLATION



**Declaration of Conformity of Final Machinery**

in accordance with Annex II, section 1.A. of the Directive 2006/42/EC

For the following products:

**Types 251GR-1/-7 Pneumatic Control Valves consisting of the Type 251GR Valve and Type 3271/Type 3277 Pneumatic Actuator**

We hereby declare that the machinery mentioned above complies with all applicable requirements stipulated in Machinery Directive 2006/42/EC.

For product descriptions of the valve and actuator, refer to:

- Type 251GR Valve (ANSI): Mounting and Operating Instructions EB 8004-GR
- Types 3271 and 3277 Actuators: Mounting and Operating Instructions EB 8310-X

Valve accessories (e.g. positioners, limit switches, solenoid valves, lock-up valves, supply pressure regulators, volume boosters and quick exhaust valves) are classified as machinery components in this declaration of conformity and do not fall within the scope of the Machinery Directive as specified in § 35 and § 46 of the Guide to Application of the Machinery Directive 2006/42/EC issued by the European Commission. In the SAMSON Manual H 02 titled "Appropriate Machinery Components for SAMSON Pneumatic Control Valves with a Declaration of Conformity of Final Machinery", SAMSON defines the specifications and properties of appropriate machinery components that can be mounted onto the above specified final machinery.

Referenced technical standards and/or specifications:

- VCI, VDMA, VGB: "Leitfaden Maschinenrichtlinie (2006/42/EG) – Bedeutung für Armaturen, Mai 2018" [German only]
- VCI, VDMA, VGB: "Zusatzdokument zum „Leitfaden Maschinenrichtlinie (2006/42/EG) – Bedeutung für Armaturen vom Mai 2018" [German only], based on DIN EN ISO 12100:2011-03

Comment:

Information on residual risks of the machinery can be found in the mounting and operating instructions of the valve and actuator as well as in the referenced documents listed in the mounting and operating instructions.

Persons authorized to compile the technical file:

SAMSON AG, Weismüllerstraße 3, 60314 Frankfurt am Main, Germany  
Frankfurt am Main, 7. November 2024

Stephan Giesen  
Director Product Management

Sebastian Krause  
Vice President Product Development

Revision no. 00

Classification: Public · SAMSON AKTIENGESELLSCHAFT · Weismüllerstraße 3 · 60314 Frankfurt, Germany

Page 1 of 1

# DECLARATION OF INCORPORATION TRANSLATION



## Declaration of Incorporation in Compliance with Machinery Directive 2006/42/EC

For the following products:

### Type 251GR Pneumatic Control Valve

We certify that the Type 251-GR Pneumatic Control Valves are partly completed machinery as defined in the Machinery Directive 2006/42/EC and that the safety requirements stipulated in Annex I, 1.1.2, 1.1.3, 1.1.5, 1.3.2, 1.3.4 and 1.3.7 are observed. The relevant technical documentation described in Annex VII, part B has been compiled.

Products we supply must not be put into service until the final machinery into which it is to be incorporated has been declared in conformity with the provisions of the Machinery Directive 2006/42/EC.

Operators are obliged to install the products observing the accepted industry codes and practices (good engineering practice) as well as the mounting and operating instructions. Operators must take appropriate precautions to prevent hazards that could be caused by the process medium and operating pressure in the valve as well as by the signal pressure and moving parts.

The permissible limits of application and mounting instructions for the products are specified in the associated data sheets as well as the mounting and operating instructions; the documents are available in electronic form on the Internet at [www.samsongroup.com](http://www.samsongroup.com).

For product descriptions of the valve, refer to:

- Type 251GR Valve (DIN): Mounting and Operating Instructions EB 8003-GR
- Type 251GR Valve (ANSI): Mounting and Operating Instructions EB 8004-GR

Referenced technical standards and/or specifications:

- VCI, VDMA, VGB: Leitfaden Maschinenrichtlinie (2006/42/EG) – Bedeutung für Armaturen, May 2018 [German only]
- VCI, VDMA, VGB: Zusatzdokument zum „Leitfaden Maschinenrichtlinie (2006/42/EG) – Bedeutung für Armaturen“ vom Mai 2018 [German only], based on DIN EN ISO 12100:2011-03

Comments:

- See mounting and operating instructions for residual hazards.
- Also observe the referenced documents listed in the mounting and operating instructions.

Persons authorized to compile the technical file:

SAMSON AG, Weismüllerstraße 3, 60314 Frankfurt am Main, Germany  
Frankfurt am Main, 7. November 2024

Stephan Giesen  
Director Product Management

Sebastian Krause  
Vice President Product Development

Revision no. 00

## 15 Appendix

### 15.1 Tightening torques, lubricants and tools

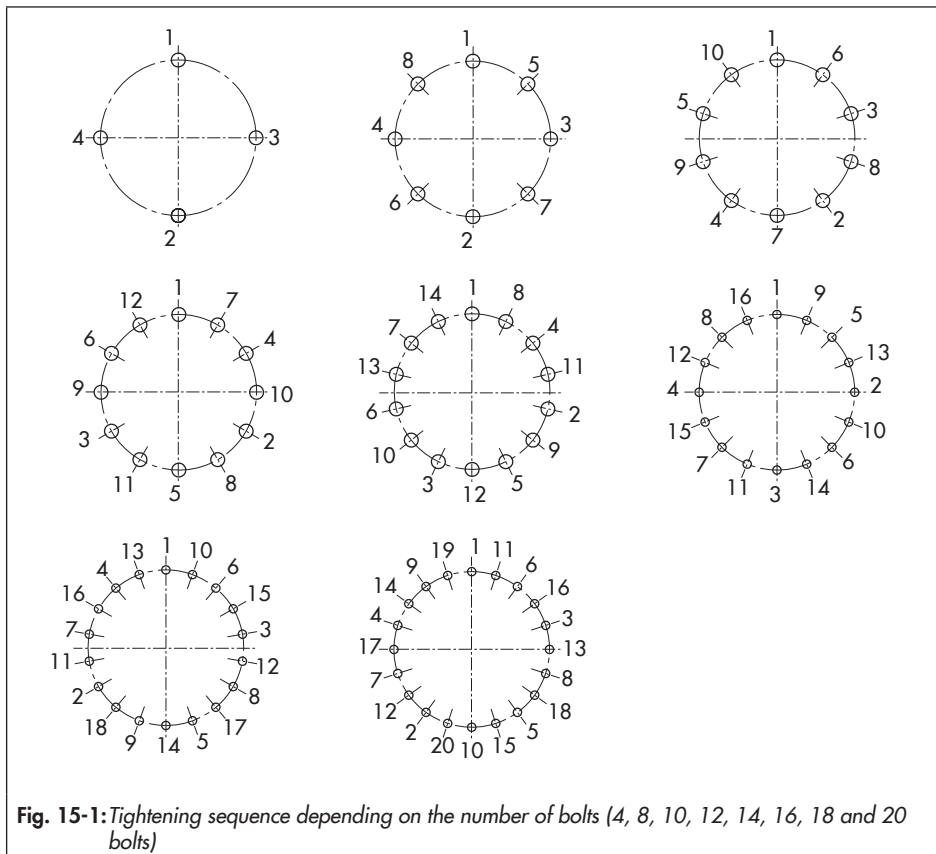

**Table 15-1:** Numerical tightening sequence of bolts numbered in the clockwise direction

Number of bolts	Tightening sequence of bolts numbered sequentially in the clockwise direction
4	1, 3, 2, 4
6	1, 5, 3, 2, 6, 4
8	1, 5, 3, 7, 2, 6, 4, 8
10	1, 5, 3, 7, 9, 2, 6, 4, 8, 10
12	1, 5, 9, 3, 7, 11, 2, 6, 10, 4, 8, 12
14	1, 5, 9, 3, 7, 11, 13, 2, 6, 10, 4, 8, 12, 14
16	1, 5, 9, 13, 3, 7, 11, 15, 2, 6, 10, 14, 4, 8, 12, 16
18	1, 13, 5, 17, 9, 3, 15, 7, 11, 2, 14, 6, 18, 10, 4, 16, 8, 12
20	1, 13, 5, 17, 9, 3, 15, 7, 19, 11, 2, 14, 6, 18, 10, 4, 16, 8, 20, 12
22	1, 13, 5, 21, 9, 3, 15, 7, 19, 11, 17, 2, 14, 6, 22, 10, 4, 16, 8, 20, 12, 18
24	1, 9, 17, 5, 13, 21, 3, 11, 19, 7, 15, 23, 2, 10, 18, 6, 14, 22, 4, 12, 20, 8, 16, 24
26	1, 9, 25, 5, 13, 21, 3, 11, 19, 7, 15, 23, 17, 2, 10, 26, 6, 14, 22, 4, 12, 20, 8, 16, 24, 18
28	1, 21, 5, 13, 25, 9, 17, 3, 23, 7, 15, 19, 11, 27, 2, 22, 6, 14, 26, 10, 18, 4, 24, 8, 16, 20, 12, 28
30	1, 21, 5, 13, 27, 9, 17, 3, 23, 7, 15, 19, 11, 25, 29, 2, 22, 6, 14, 26, 10, 18, 4, 24, 8, 16, 20, 12, 26, 30
32	1, 21, 5, 13, 25, 9, 17, 29, 3, 23, 7, 15, 19, 11, 27, 31, 2, 22, 6, 14, 26, 10, 18, 30, 4, 24, 8, 16, 20, 12, 28, 32

→ Tighten radially arranged pressure-retaining bolting gradually according to the prescribed tightening sequence. Apply the target torque over several rounds.

### 15.1.1 Tightening torques

All tightening torques specified in Nm

→ Use a torque wrench to apply and check the tightening torques.

**Table 15-2:** *Tightening torques to install the seat*

Nominal size NPS	Tightening torque for retaining ring for seat (221)
½	90
1	120
1½	200
2	440
3	1200
4	1700
6	5300
8	8900

**Table 15-3:** *Tightening torques for nuts (14) on valve bonnet (2/21/101)*

Tightening torque for body nut (14)				
Nominal size NPS	Pressure rating			
	Class			
	150	300	600	900
½	40	40	40	45
1	45	45	45	50
1½	70	75	75	80
2	90	95	95	150
3	155	165	175	360
4	175	185	220	330
6	410	420	340	570
8	690	690	1000	–
10	760	760	1190	–
12	660	660	1160	–

**Table 15-4:** *Tightening torques for plug/piston stem (36)*

Stem diameter Ø in mm	Tightening torque for plug stem (36) in plug (5)/piston stem (36) in piston (5)
12	25
16	30
25	35
40	On request

**Table 15-5:** *Tightening torques for threaded bushing (8) (version with centrally fastened packing)*

Stem diameter Ø in mm	Packing form				
	Adjustable (without internal spring)		Live-loaded (with internal spring)		
	GZA1	PZA4	PZS1	PZS2	PZS3
12	–	–	20	20	–
16	–	–	25	25	–
25	–	–	90	90	–
40	–	–	355	355	–

**Table 15-6:** *Tightening torques for packing nuts (163) (live-loaded packing with packing flange loaded by external spring elements)*

Stem diameter Ø in mm	Packing form						
	PXS1	PXS2	PXS3	GXS1	GXS2	GXS3	PXS4
12	On request	On request	–	On request	On request	On request	–
16	6	On request	–	On request	On request	On request	–
25	On request	On request	–	On request	On request	On request	–
40	On request	On request	–	On request	On request	On request	–

**Table 15-7:** *Tightening torques for packing nuts (163) (adjustable packing with packing flange not loaded by spring elements)*

Stem diameter Ø in mm	Packing form				
	PXA1	GXA1	GXA2	GXA3	PXA4
12	–	Max. 18	–	–	–
16	–	On request	–	–	–
25	–	On request	–	–	–
40	–	On request	–	–	–

### 15.1.2 Tools

In addition to the standard tools expected to be available, special tools are required to assemble and remove some parts. Use adjustable torque wrenches with a stop signal or that indicate the torque being applied to achieve the right tightening torques. Valves in large nominal sizes often require tightening torques that can only be achieved through additional torque multiplication by using a torque multiplier or hydraulic power tool.

**Contact SAMSON's After-sales Service to obtain specially designed tools required for service or conversion work.**

→ Contact our after-sales service.

### 15.1.3 Lubricants

---

#### **⚠ WARNING**

***Exposure to hazardous substances poses a serious risk to health.***

*Certain lubricants and cleaning agents are classified as hazardous substances. These substances have a special label and a material safety data sheet (MSDS) issued by the manufacturer.*

- ➔ *Make sure that an MSDS is available for any hazardous substance used. If necessary, contact the manufacturer to obtain an MSDS.*
  - ➔ *Inform yourself about the hazardous substances and their correct handling.*
- 

To minimize friction, apply a suitable lubricant to the sliding surfaces of the nuts, bolts and washers before tightening them. Optimum lubrication is achieved by lubricating all sliding surfaces (e.g. threads, seating surfaces on nuts, contact surfaces on moving bolt heads if applicable). This is required to achieve the required bolt tension when applying the specified tightening torques. It also ensures that the bolt connections can still be undone without any problems after they have been exposed to thermal stress.

Apply only a thin film of lubricant to the entire surface that needs lubrication.



**Table 15-8: Recommended lubricant**

Item <sup>2)</sup>	Application	Trade name	Temperature range in °F (°C)	Color	Material no.
113/ 242	Chemical-resistant, high-temperature grease <sup>1)</sup> e.g. lubricant for packings	Gleitmo® 591	-13 to +500 (-25 to +260)	White	8150-4000 (10 g)
					8150-0111 (1 kg)
114	High-temperature lubricant (paste): item 13/14, item 32/33, item 8 (threaded bushing) <sup>3)</sup> , item 92	Gleitmo® 1763 V	-4 to +1832 (-20 to +1000)	Gray	8150-4008 (250 g)
					100194184 (1 kg)
243	Special high-temperature anti-seize paste for bolted connections: items 221, 103	Gleitmo® 165	-40 to +2192 (-40 to +1200)	Gray	1000036865 (1 kg)
113	Fully synthetic special grease Lubricant for packings	SYN-setral-INT/200 V-2	-58 to +536 (-50 to +280)	White	100141157 (100 g)
					100141160 (1 kg)

<sup>1)</sup> Components that are to be lubricated and tools used for lubrication must be free of oil and grease.

<sup>2)</sup> According to device BOM

<sup>3)</sup> Depending on the application (process medium)

## 15.2 Spare parts

1	Valve body	63	Support element (version with screwed-in seat)
2	Standard bonnet	363	Support element (pressure-balanced version with screwed-in seat)
4	Seat	463	Cylinder (cage version)
5	Plug Piston	66	Clamping ring for flow divider ST1
7 <sup>1)</sup>	Bushing	80	Nameplate
8	Threaded bushing Packing follower	81	Grooved pin
9	Stem connector nut	82	Bolt
10	Lock nut	83	Hanger
13	Stud	84	Travel indicator scale
14	Hex nut	89	Dust shield
15	Packing assembly	91	Protective caps on valve inlet and outlet ports
17	Spiral gasket	92	Castellated nut
21	Insulating section	93	Expansion sleeve
22	Intermediate piece	101	Valve bonnet (version with bellows seal)
32	Bolt	103	Locking pin
33	Nut	124	Seat retainer (version with clamped-in seat)
36	Plug stem Piston stem	324	Seat retainer (pressure-balanced version with clamped-in seat)
37	Plug stem with metal bellows Piston stem with metal seal	424	Cage
39	Spiral gasket	126	Spiral gasket
41	Bellows nut	127	Spiral gasket
42	Screw plug (test connection)	162	Packing flange
43	Gasket	163	Packing nuts for packing flange (including disk springs when packing flange is loaded by external spring elements)
45	Seal (pressure balancing)	164	Stud
47 <sup>1)</sup>	Plug guide (version with pressure balancing)	182	Spiral gasket
51	Guide ring	221	Retaining ring for seat
60	Yoke including external anti-rotation fixture	223	Anti-rotation fixture (bellows seal)
62	Flow divider		

<sup>1)</sup> Included in assembly with items 363 and 324

Packing with packing flange (live-loaded by external spring elements)

Centrally fastened packing (live-loaded or adjustable, depending on the packing set)

Packing with packing flange (adjustable without external spring elements)

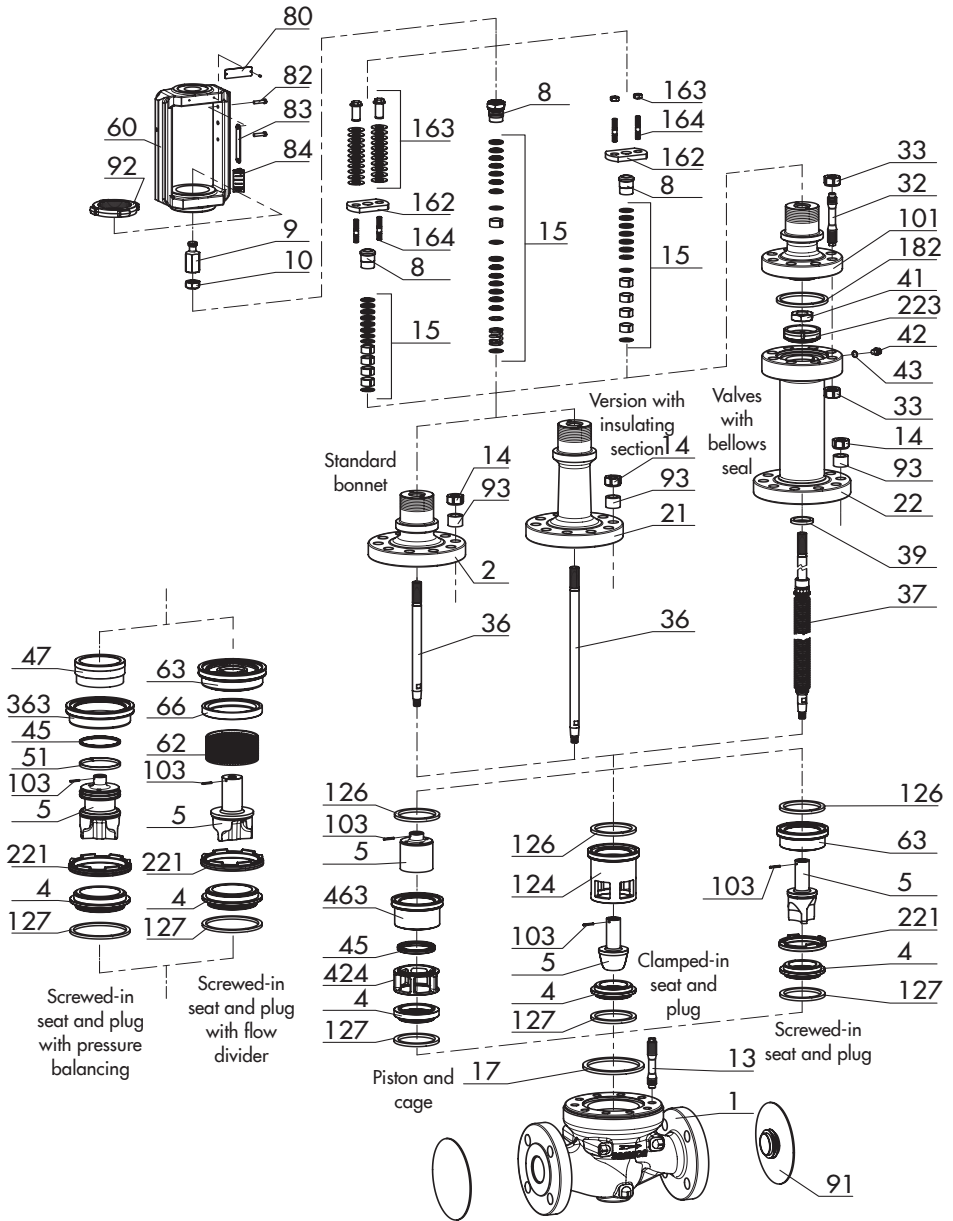

### 15.3 After-sales service

Contact our after-sales service for support concerning service or repair work or when malfunctions or defects arise.

#### E-mail address

You can reach our after-sales service at [aftersaleservice@samsongroup.com](mailto:aftersaleservice@samsongroup.com).

#### Addresses of SAMSON AG and its subsidiaries

The addresses of SAMSON AG, its subsidiaries, representatives and service facilities worldwide can be found on our website ([www.samsongroup.com](http://www.samsongroup.com)) or in all SAMSON product catalogs.

#### Required specifications

Please submit the following details:

- Order number and position number in the order
- Type, model number, nominal size and valve version
- Pressure and temperature of the process medium
- Flow rate in m<sup>3</sup>/h
- Direction of flow
- Bench range of the actuator (e.g. 0.2 to 1 bar)
- Is a strainer installed?
- Installation drawing









SAMSON AKTIENGESELLSCHAFT  
Weismüllerstraße 3 · 60314 Frankfurt am Main, Germany  
Phone: +49 69 4009-0 · Fax: +49 69 4009-1507  
samson@samsongroup.com · www.samsongroup.com