

MOUNTING AND OPERATING INSTRUCTIONS

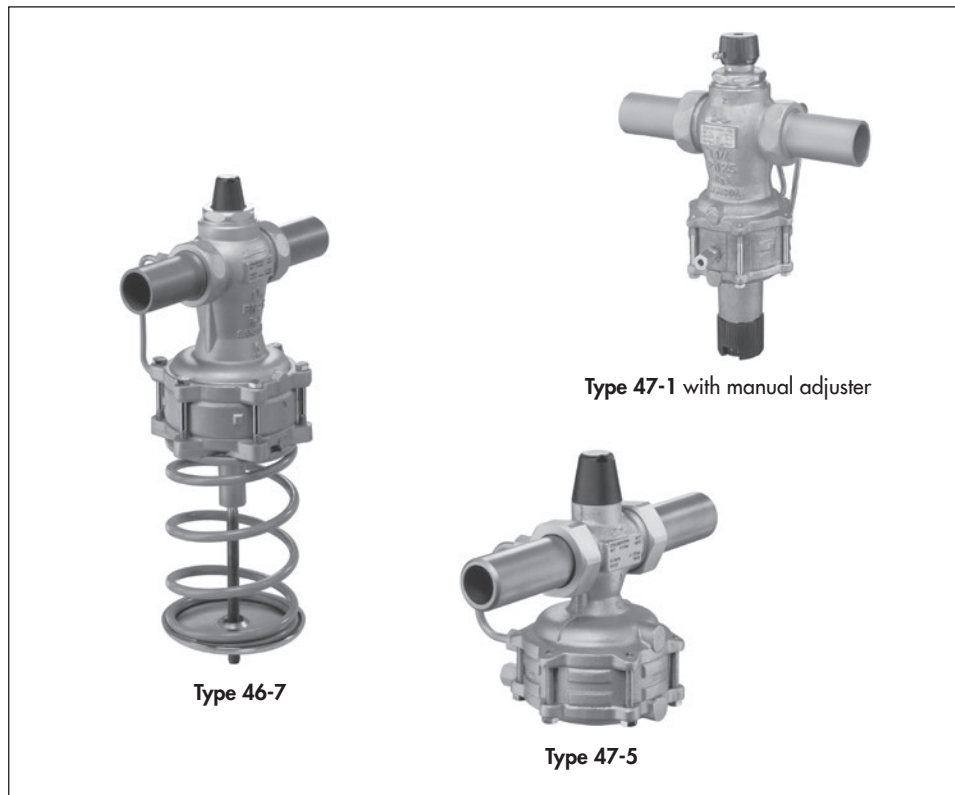

EB 3131 EN

Translation of original instructions



Types 46-7, 47-5 and 47-1 Self-operated Regulators Flow and Differential Pressure or Pressure Regulators

Note on these mounting and operating instructions

These mounting and operating instructions assist you in mounting and operating the device safely. The instructions are binding for handling SAMSON devices. The images shown in these instructions are for illustration purposes only. The actual product may vary.

- For the safe and proper use of these instructions, read them carefully and keep them for later reference.
- If you have any questions about these instructions, contact SAMSON's After-sales Service Department (aftersaleservice@samsongroup.com).



Documents relating to the device, such as the mounting and operating instructions, are available on our website at www.samsongroup.com > **Service & Support > Downloads > Documentation.**

Definition of signal words

DANGER

Hazardous situations which, if not avoided, will result in death or serious injury

WARNING

Hazardous situations which, if not avoided, could result in death or serious injury

NOTICE

Property damage message or malfunction

Note

Additional information

Tip

Recommended action

1	Safety instructions and measures	5
1.1	Notes on possible severe personal injury	8
1.2	Notes on possible personal injury	8
1.3	Notes on possible property damage	10
2	Markings on the device	12
2.1	Material identification number	12
3	Design and principle of operation	13
3.1	Mounting parts	16
3.2	Versions	16
3.3	Technical data	17
4	Measures for preparation	21
4.1	Unpacking	21
4.2	Transporting and lifting	21
4.3	Storage	21
4.4	Preparation for installation	22
5	Mounting and start-up	23
5.1	Mounting orientation	23
5.2	Additional fittings	24
5.3	Putting the regulator into operation	24
6	Operation	26
6.1	Adjusting the set points	26
6.1.1	Flow control	26
6.1.2	Differential pressure control	29
7	Servicing	30
7.1	Cleaning and replacing the plug	32
7.2	Replacing the diaphragm	33
7.3	Tightening torques	35
7.4	Preparation for return shipment	35
7.5	Ordering spare parts and operating supplies	35
8	Malfunctions	35
9	Decommissioning and removal	38
9.1	Decommissioning	38
9.2	Disposal	39

Contents

10	Annex.....	39
10.1	After-sales service	39
11	Certificates	40

1 Safety instructions and measures

Intended use

The Type 46-7 and Type 47-5 Regulators are designed for flow rate and differential pressure control. The Type 47-1 Regulator is designed for flow rate and differential pressure control or flow rate and pressure control. The regulators are mainly used in district heating supply networks and industrial plants. The regulator and actuator are designed to operate under exactly defined conditions (e.g. operating pressure, process medium, temperature). Therefore, operators must ensure that the regulator and actuator are only used in operating conditions that meet the specifications used for sizing the devices at the ordering stage. In case operators intend to use the devices in applications or conditions other than those specified, contact SAMSON.

SAMSON does not assume any liability for damage resulting from the failure to use the device for its intended purpose or for damage caused by external forces or any other external factors.

➔ Refer to the technical data and nameplate for limits and fields of application as well as possible uses.

Reasonably foreseeable misuse

The regulator is not suitable for the following applications:

- Use outside the limits defined during sizing and by the technical data

Furthermore, the following activities do not comply with the intended use:

- Use of non-original spare parts
- Performing service and repair work not described

Qualifications of operating personnel

The regulator must be mounted, started up, serviced and repaired by fully trained and qualified personnel only; the accepted industry codes and practices must be observed. According to these mounting and operating instructions, trained personnel refers to individuals who are able to judge the work they are assigned to and recognize possible hazards due to their specialized training, their knowledge and experience as well as their knowledge of the applicable standards.

Safety instructions and measures

Personal protective equipment

We recommend checking the hazards posed by the process medium being used (e.g.

▶ GESTIS (CLP) hazardous substances database).

- Provide protective equipment (e.g. safety gloves, eye protection) appropriate for the process medium used.
- Wear hearing protection when working near the valve. Follow the instructions given by the plant operator.
- Check with the plant operator for details on further protective equipment.

Revisions and other modifications

Revisions, conversions or other modifications of the product are not authorized by SAMSON. They are performed at the user's own risk and may lead to safety hazards, for example. Furthermore, the product may no longer meet the requirements for its intended use.

Warning against residual hazards

To avoid personal injury or property damage, plant operators and operating personnel must prevent hazards that could be caused in the device by the process medium, the operating pressure or by moving parts by taking appropriate precautions. Plant operators and operating personnel must observe all hazard statements, warnings and caution notes in these mounting and operating instructions, especially for installation, start-up and service work.

We also recommend checking the hazards posed by the process medium being used (e.g.

▶ GESTIS (CLP) hazardous substances database).

- Observe safety measures for handling the device as well as fire prevention and explosion protection measures.

Safety features

The Types 46-7, 47-5 and 47-1 Regulators do not have any special safety features. When relieved of pressure and with open restriction, the regulators are opened by the force of the set point springs.

Responsibilities of the operator

Operators are responsible for proper use and compliance with the safety regulations. Operators are obliged to provide these mounting and operating instructions as well as the referenced documents to the operating personnel and to instruct them in proper operation. Furthermore, operators must ensure that operating personnel or third parties are not exposed to any danger.

Operators are additionally responsible for ensuring that the limits for the product defined in the technical data are observed. This also applies to the start-up and shutdown procedures. Start-up and shutdown procedures fall within the scope of the operator's duties and, as such, are not part of these mounting and operating instructions. SAMSON is unable to make any statements about these procedures since the operative details (e.g. differential pressures and temperatures) vary in each individual case and are only known to the operator.

Responsibilities of operating personnel

Operating personnel must read and understand these mounting and operating instructions as well as the referenced documents and observe the specified hazard statements, warnings and caution notes. Furthermore, operating personnel must be familiar with the applicable health, safety and accident prevention regulations and comply with them.

Referenced standards, directives and regulations

The regulators comply with the requirements of the European Pressure Equipment Directive 2014/68/EU. Devices with a CE marking have an EU declaration of conformity, which includes information about the applied conformity assessment procedure. The EU declaration of conformity is included in the annex of these instructions (see section 11).

Non-electric regulator versions whose bodies are not lined with an insulating material coating do not have their own potential ignition source according to the risk assessment stipulated in EN 13463-1: 2009, section 5.2, even in the rare incident of an operating fault. Therefore, such valve versions do not fall within the scope of Directive 2014/34/EU.

→ For connection to the equipotential bonding system, observe the requirements specified in Clause 6.4 of EN 60079-14 (VDE 0165-1).

Referenced documentation

The following documents apply in addition to these mounting and operating instructions:

- Mounting and operating instructions for
 - e.g. **Type 1 N or 1 NI Strainer** ▶ EB 1010
 - e.g. **Type 2 N or 2 NI Strainer** ▶ EB 1015
- Mounting and operating instructions as well as data sheets for additional fittings (e.g. shut-off valves, pressure gauges etc.).

1.1 Notes on possible severe personal injury

DANGER

Risk of bursting in pressure equipment.

Regulators and pipelines are pressure equipment. Improper opening can lead to device components bursting.

- Observe the maximum permissible pressure for regulator and plant.
- Before starting any work on the device, depressurize all plant sections affected as well as the regulator.
- Drain the process medium from all the plant sections affected as well as the regulator.
- If necessary, a suitable overpressure protection must be installed on site in the plant section.
- Wear personal protective equipment.

1.2 Notes on possible personal injury

WARNING

Crush hazard arising from moving parts.

The regulator contains moving parts (actuator and plug stem), which can injure hands or fingers if inserted into the valve.

- Do not insert hands or fingers between the set point springs while the regulator is in operation.
- Before performing any work on the regulator, depressurize the plant. Disconnect or shut off the external control line.

⚠ WARNING**Risk of personal injury due to incorrect operation, use or installation as a result of information on the regulator being illegible.**

Over time, markings, labels and nameplates on the regulator may become covered with dirt or become illegible in some other way. As a result, hazards may go unnoticed and the necessary instructions not followed. There is a risk of personal injury.

- Keep all relevant markings and inscriptions on the device in a constantly legible state.
- Immediately renew damaged, missing or incorrect nameplates or labels.

Risk of personal injury due to residual process medium in the regulator.

While working on the regulator, residual process medium can escape and, depending on its properties, may lead to personal injury, e.g. (chemical) burns.

- If possible, drain the process medium from all the plant sections affected and the regulator.
- Wear protective clothing, safety gloves and eye protection.

Risk of personal injury due to pressurized components and process medium being discharged.

Incorrect opening of pressure equipment or mounting parts may lead to the process medium escaping to the atmosphere.

- Do not loosen the control line while the regulator is pressurized.

Risk of hearing loss or deafness due to loud noise.

The noise emissions depend on the regulator version, plant facilities and process medium.

- Wear hearing protection when working near the valve. Follow the instructions given by the plant operator.

⚠ WARNING

Risk of burn injuries due to hot or cold components and pipelines.

Depending on the process medium, regulator components and pipelines may get very hot or cold and cause burn injuries.

- Allow components and pipelines to cool down or warm up to the ambient temperature.
- Wear protective clothing and safety gloves.

Damage to health relating to the REACH regulation.

If a SAMSON device contains a substance listed as a substance of very high concern on the candidate list of the REACH regulation, this is indicated on the SAMSON delivery note.

- Information on safe use of the part affected ► www.samsongroup.com/en/about-samson/material-compliance/reach-regulation/.

1.3 Notes on possible property damage

ⓘ NOTICE

Risk of regulator damage due to contamination (e.g. solid particles) in the pipeline.

The plant operator is responsible for cleaning the pipelines in the plant.

- Flush the pipelines before start-up.

Risk of regulator damage due to unsuitable medium properties.

The regulator is designed for process media with defined properties.

- Only use process media specified for sizing the valve.

Risk of leakage and regulator damage due to excessively high or low tightening torques.

Observe the specified torques when tightening regulator components. Excessive tightening torques lead to parts wearing out more quickly. Parts that are too loose may cause leakage.

- Observe the tightening torques specified in section 7.3.

! NOTICE**Incorrect control due to the formation of ice on the regulator.**

Medium temperatures below 0 °C may cause ice to form on the regulator, depending on the air humidity. This may affect, in particular, the functioning of the actuator stem guide or set point adjuster.

- Prevent the formation of ice by taking appropriate precautions (e.g. enclosure, trace heater etc.). The plant operator is responsible for selecting and implementing appropriate precautions.

Regulator damage due to condensed glycol.

In principle, the materials are also resistant to high concentrations of glycol. Nevertheless, glycol reacts when it comes into contact with metals and causes acids to form. We cannot prevent this reaction.

- Use suitable inhibitors. The plant operator is responsible for the selection and use of suitable inhibitors.
- Risk of regulator damage due to incorrectly attached slings.
- Do not attach load-bearing slings to the regulator.
- Risk of regulator damage due to the use of unsuitable lubricants.
- The lubricants to be used depend on the regulator material. Unsuitable lubricants may corrode and damage surfaces.
- Only use lubricants approved by SAMSON.
When in doubt, consult SAMSON.
- Risk of regulator damage due to the use of unsuitable tools.
- Certain tools are required to work on the regulator.
- Only use tools approved by SAMSON.
When in doubt, consult SAMSON.
- Risk of the process medium being contaminated through the use of unsuitable lubricants and/or contaminated tools and components.
- Keep the regulator and the tools used free from solvents and grease.
- Make sure that only suitable lubricants are used.

2 Markings on the device

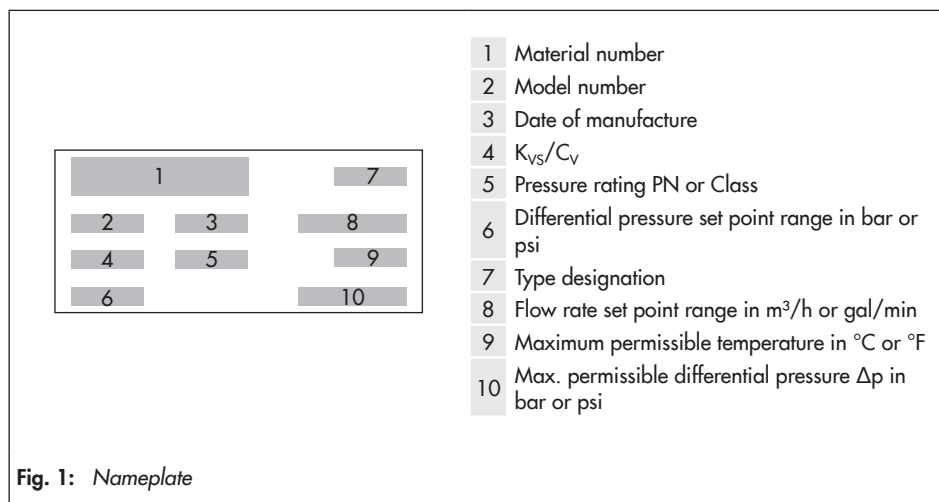

2.1 Material identification number

Specifying the configuration ID, you can contact us to find out which material is used. The material number is specified on the nameplate (item 1). For more details on the nameplate, see Fig. 1.

3 Design and principle of operation

The combined regulators basically consist of a valve body (1) with a balanced plug as well as a closing actuator with two operating diaphragms. The regulators are used to limit the differential pressure and flow rate to the set points adjusted at the actuator. The regulator closes when the differential pressure or flow rate increases.

The medium flows through the regulator in the direction indicated by the arrow. The areas released by the restriction (1.2) and the plug (3) determine the flow rate and the differential pressure Δp or downstream pressure p_2 (Type 47-1). The differential pressure Δp is converted by the first operating diaphragm (6.1) and the differential pressure

created at the restriction based on the flow rate by the second operating diaphragm (6.3) into a positioning force. The largest signal is always used to control the regulator.

Type 46-7 and Type 47-5

To control the flow rate, the low pressure downstream of the restriction (1.2) is transmitted through a hole in the plug (3) to the top diaphragm chamber A. The high pressure of \dot{V} is transmitted through the attached control line (11) to the diaphragm chamber B.

To control the differential pressure, the high pressure of Δp must be transmitted through the external control line (13), which is attached on the site of installation, to the bottom diaphragm chamber D. The low pressure of Δp is equal to the high pressure of the \dot{V} and acts in the diaphragm

Legend for Fig. 2 and Fig. 3

1	Valve body	12	Control line (+) Δp
1.1	Connection nut with seal and welding end	13	External control line (+) Δp
1.2	Restriction	14	External control line (-) Δp
2	Seat	15	Screws
3	Plug with guide nipple	16	Lock nut
4	Plug stem	17	Set point screw (flow rate, SW 4)
5	Valve spring	18	Cap
6	Actuator	19	Manual adjuster (differential pressure)
6.1	First operating diaphragm	20	Spindle
6.2	First actuator stem	21	Support
6.3	Second operating diaphragm	22	Bottom section of the housing
6.4	Second actuator stem	23	Spring plate
7	Distance ring	24	Nut
8	Set point spring (differential pressure)	25	Stopper for plug
9	Spring plate		
10	Set point adjuster (differential pressure)		A to D = Diaphragm chambers
11	Control line (+) \dot{V}		

Markings on the device

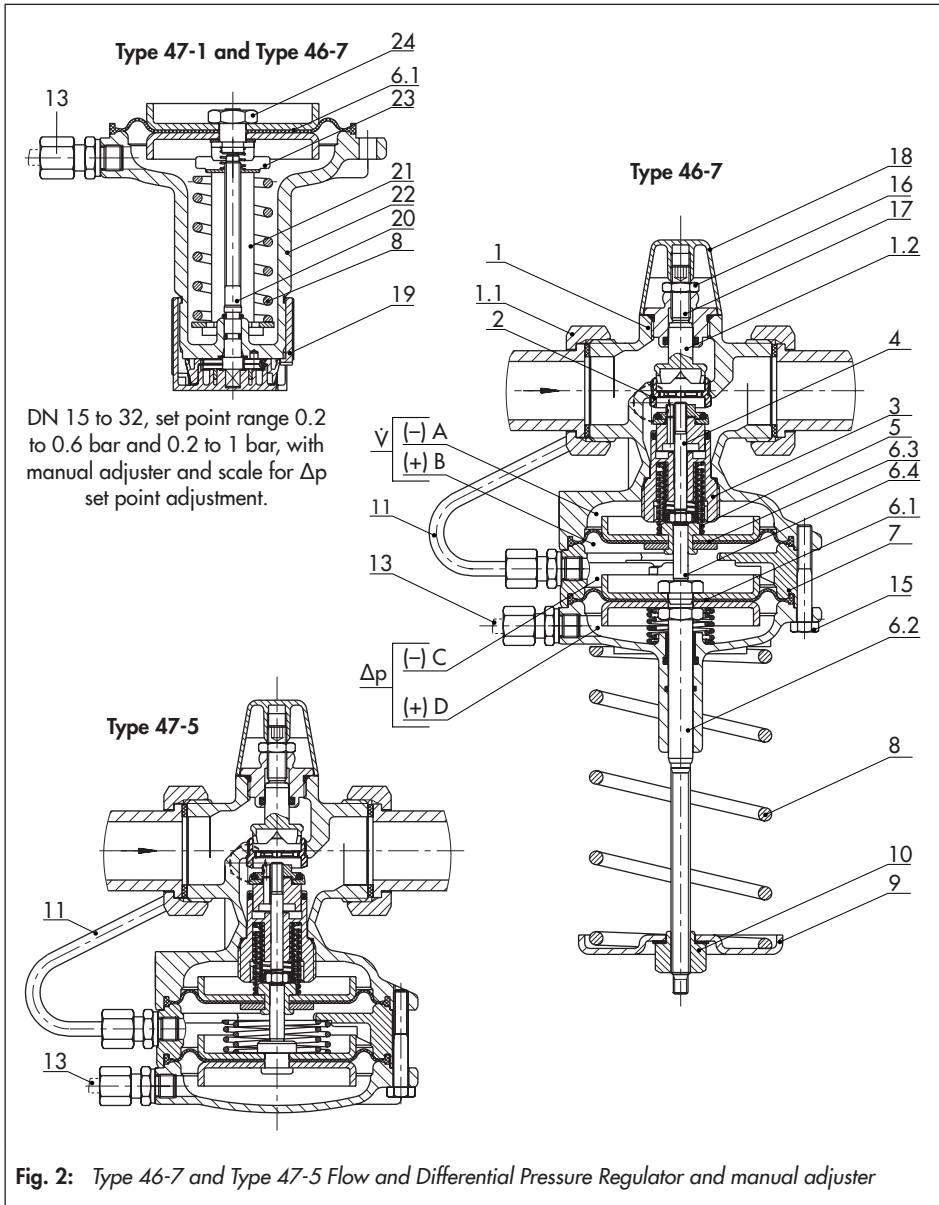

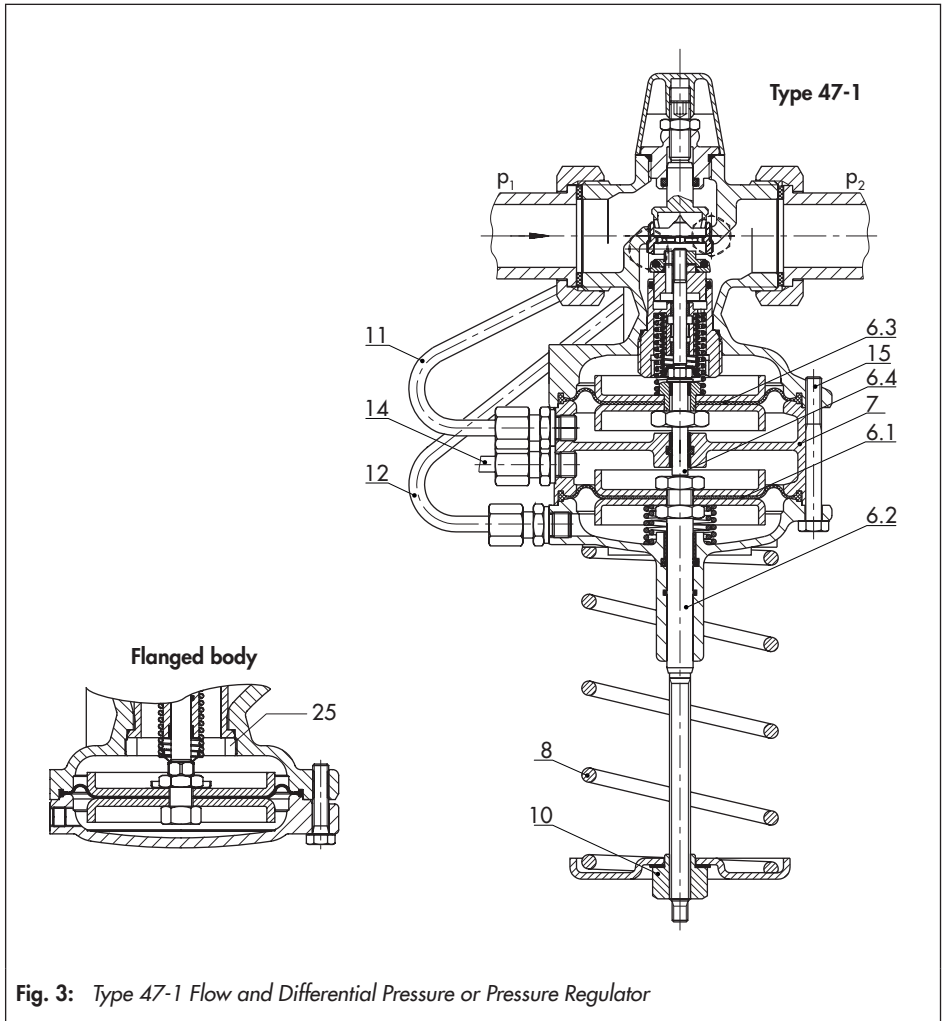

Design and principle of operation

chambers B and C which are connected to each other.

Type 47-1

To control the flow rate, the low pressure of \dot{V} downstream of the restriction (1.2) is transmitted through a hole in the plug (3) to the top diaphragm chamber A.

The high pressure of Δp is transmitted through the attached control line (11) to the diaphragm chamber B. To control the differential pressure, the high pressure of Δp is transmitted through the attached control line (12) to the bottom diaphragm chamber D.

The low pressure of Δp must be transmitted through the external control line (14), which is attached on the site of installation, to the diaphragm chamber C.

When the Type 47-1 is used as a flow regulator and pressure reducer, diaphragm chamber D is connected with the downstream pressure p_2 . The control line connection of diaphragm chamber C remains open to the atmosphere.

3.1 Mounting parts

See Table 1.

Table 1: *Mounting parts*

Valve size	DN 15	DN 20	DN 25	DN 32	DN 40	DN 50
Welding ends ¹⁾	1400-6500	1400-6501	1400-6502	1400-6509	1400-6510	1400-6511
Threaded ends ¹⁾	1400-6503	1400-6504	1400-6505	1400-6512	1400-6513	1400-6514
Gasket	8413-3000	8413-3001	8413-3002	8413-3003	8413-3004	8413-3005

¹⁾ Pair including flat gasket

3.2 Versions

Type 46-7 and Type 47-5 Flow and Differential Pressure Regulator · Designed for the installation in the low-pressure pipe, e.g. return flow pipe of a district heating station.

- **Type 46-7** · With adjustable flow rate and differential pressure set point · With internal overload protection (excess pressure limiter) in the actuator
- **Type 47-5** · With fixed differential pressure set point · Adjustable flow rate set point · With internal overload protection (excess pressure limiter) in the actuator

Type 47-1 Flow and Differential Pressure or Pressure Regulator · Designed for installation in the high-pressure pipe, e.g. flow pipe.

- **Type 47-1** · With adjustable flow rate and differential pressure or pressure set point

i Note

Flow regulator with Type 5824 or Type 5825 Electric Actuator or alternatively with Type 2430 Control Thermostat. In these regulators, the signal of an electric control device can be applied to achieve additional temperature control by altering the restriction position. See Mounting and Operating Instructions ► EB 3135-2, ► EB 5824-1, ► EB 5824-2 or ► EB 2430.

3.3 Technical data

Min. differential pressure Δp_{\min}

The minimum required differential pressure Δp_{\min} across the regulator is calculated as follows:

$$\Delta p_{\min} = \Delta p_{\text{restriction}} + \left(\frac{\dot{V}}{K_{VS}} \right)^2$$

Δp_{\min} Minimum differential pressure across the regulator in bar

$\Delta p_{\text{restriction}}$ Differential pressure created at the restriction for measuring the flow rate

\dot{V} Adjusted flow rate in m³/h

K_{VS} Flow coefficient in m³/h

Dimensions in mm · Weights in kg

The lengths and heights in the dimensional drawings are shown on pages 19 and 20.

Table 2: Materials · Material number according to DIN EN

Body	Red brass CC499K (Rg 5) · Spheroidal graphite iron EN-GJS-400-18-LT ¹⁾	
Pressure rating	PN 16 · PN 25	
Seat	Stainless steel 1.4305	
Plug	PN 25	Brass, resistant to dezincification, with EPDM soft seal ²⁾
	PN 16	Brass, resistant to dezincification and plastic with EPDM soft seal
Valve springs	Stainless steel 1.4310	
Restriction	Brass, free of dezincification	
Operating diaphragm	EPDM with fabric reinforcement ²⁾	
Seals	EPDM ²⁾	

¹⁾ Additional version in DN 32, 40 and 50: valve with flanged body made of spheroidal graphite iron

²⁾ Special version in PN 25, e.g. for mineral oils: FKM

Design and principle of operation

Table 3: Technical data

Valve size	DN 15				DN 20	DN 25	DN 32 ³⁾	DN 40 ³⁾	DN 50 ³⁾
K _{VS} coefficient	0.4 ¹⁾	1 ¹⁾	2.5	4 ¹⁾	6.3	8	12.5	16/20 ³⁾	20/25 ³⁾
X _{Fz} value	0.6				0.55	0.55/0.45 ³⁾			0.45/ 0.4 ³⁾
Pressure rating	PN 16/25					PN 25			
Max. permissible differential pressure Δp across the regulator	10 ²⁾ /20 bar							16 bar	
Max. permissible temperature	Liquids: 130 °C ²⁾ /150 °C · Air and nitrogen: 150 °C ⁴⁾								
Pressure above adjusted diff. pressure set point at which internal excess pressure limiter responds (Types 46-7 and 47-5)	0.5 bar								
Conformity	CE · ENEC								
Differential pressure set point ranges									
Type 46-7 and Type 47-1: continuously adjustable	0.2 to 0.6 bar 0.2 to 1 bar 0.5 to 2 bar					0.2 to 0.5 bar 0.2 to 1 bar 0.5 to 2 bar			
Types 47-5 · Fixed set point	0.2 bar · 0.3 bar · 0.4 bar · 0.5 bar								

- 1) Special versions
2) For PN 16 version

3) Additional version: regulator with flanged body made of spheroidal graphite iron (EN-GJS-400-18-LT)

4) Only in PN 25 version and diaphragm and seals made of FKM

Table 4: Regulator without connecting parts

Valve size	DN 15	DN 20	DN 25	DN 32 ¹⁾	DN 40 ¹⁾	DN 50 ¹⁾
Pipe \varnothing d	21.3	26.8	32.7	42	48	60
Connection R	G 3/4	G 1	G 1 1/4	G 1 3/4	G 2	G 2 1/2
Width across flats SW	30	36	46	59	65	82
Length L	65	70	75	100	110	130
H	65			85		
H1	Type 46-7	248		265	415	
	Type 47-1	265		285	425	
	Type 47-5	108		125	175	
H2	Type 46-7	185		205	-	
	Type 47-1	200		220		
H3	75			95		
$\varnothing D$	116				160	

- 1) Additional version: regulator with flanged body

Table 5: Regulator with connecting parts · Dimensions in mm

Valve size	DN 15	DN 20	DN 25	DN 32	DN 40	DN 50	
With welding ends							
L1	210	234	244	268	294	330	
Weight, approx. kg	Type 46-7	2.6	2.7	2.8	4	12	12.5
	Type 47-1						
	Type 47-5						
With threaded ends							
L2	129	144	159	192	206	228	
Male thread A	G ½	G ¾	G 1	G 1¼	G 1½	G 2	
Weight, approx. kg	Type 46-7	2.6	2.7	2.8	4	12	12.5
	Type 47-1						
	Type 47-5						
With flanges ^{1) 2)} or with flanged body (DN 32 to 50)							
L3	130	150	160	180	200	230	
Weight, approx. kg	Type 46-7	4.0	4.7	5.3	7.2	16.0	17.5
	Type 47-1						
	Type 47-5						

1) PN 16/25

2) Flanges are already mounted on regulators in DN 40 and 50.

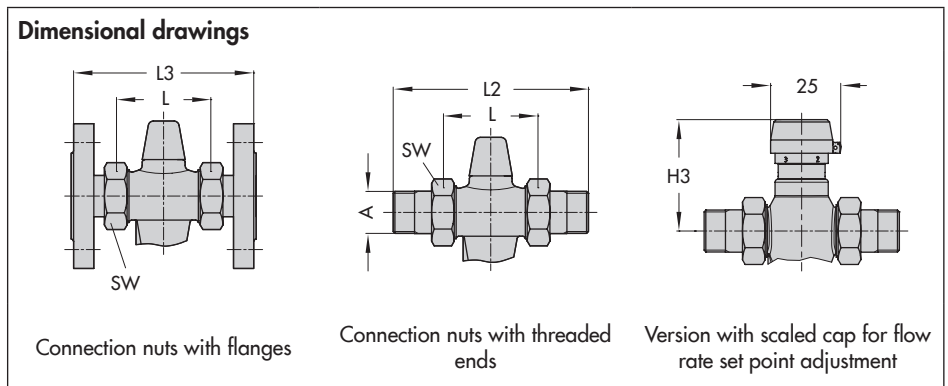

Dimensional drawings

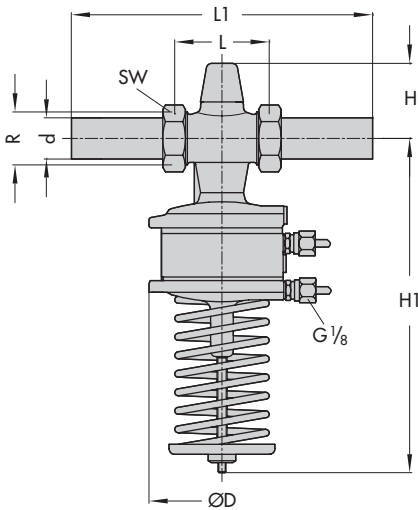

Type 46-7, Type 47-1 · DN 15 to 50 with welding ends

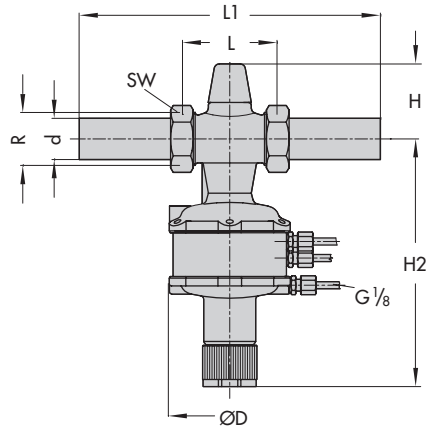

Version with manual adjuster for flow rate set point adjustment

Type 46-7, Type 47-1 · DN 15 to 32, set point ranges 0.2 to 0.6 and 0.2 to 1 bar with welding ends

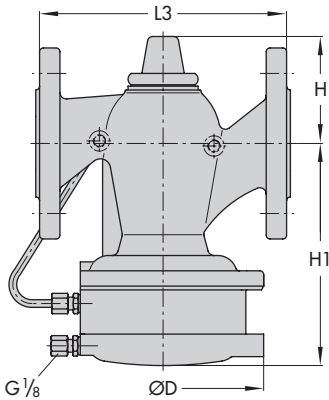

Type 47-5 · With flanged valve body (DN 32 to 50)

i Note

The dimensions and weights of valves with flanged bodies (DN 32, 40 and 50) are the same as valves with screwed-on flanges.

4 Measures for preparation

After receiving the shipment, proceed as follows:

1. Check the scope of delivery. Compare the shipment received with the delivery note.
2. Check the shipment for transportation damage. Report any damage to SAMSON and the forwarding agent (refer to delivery note).

4.1 Unpacking

i Note

Do not remove the packaging until immediately before installation.

Proceed as follows to lift and install the device:

1. Remove the packaging from the device.
2. Dispose of the packaging in accordance with the valid regulations.

4.2 Transporting and lifting

Due to the low service weight, lifting equipment is not required to lift and transport the regulator (e.g. to install it into the pipeline).

Transport instructions

- Protect the device against external influences (e.g. impact).
- Do not damage the corrosion protection (paint, surface coatings). Repair any damage immediately.
- Protect the device against moisture and dirt.
- Observe the permissible ambient temperatures (see section 3.3).

4.3 Storage

! NOTICE

Risk of regulator damage due to improper storage.

- *Observe the storage instructions.*
 - *Avoid long storage times.*
 - *Contact SAMSON in case of different storage conditions or longer storage times.*
-

i Note

We recommend to regularly check the device and the prevailing storage conditions during long storage periods.

Storage instructions

- Protect the device against external influences (e.g. impact).

Measures for preparation

- Do not damage the corrosion protection (paint, surface coatings). Repair any damage immediately.
- Protect the device against moisture and dirt. Store it at a relative humidity of less than 75 %. In damp spaces, prevent condensation. If necessary, use a drying agent or heating.
- Make sure that the ambient air is free of acids or other corrosive media.
- Observe the permissible ambient temperatures (see section 3.3).
- Do not place any objects on the device.

Special storage instructions for elastomers

Elastomer, e.g. diaphragm

- To keep elastomers in shape and to prevent cracking, do not bend them or hang them up.
- We recommend a storage temperature of 15 °C for elastomers.
- Store elastomers away from lubricants, chemicals, solutions and fuels.



Tip

SAMSON's After-sales Service can provide more detailed storage instructions on request.

4.4 Preparation for installation

Proceed as follows:

- Flush the pipelines.

i Note

The plant operator is responsible for cleaning the pipelines in the plant.

- Check the regulator to make sure that it is clean.
- Check the regulator for damage.
- Check to make sure that the type designation, valve size, material, pressure rating and temperature range of the regulator match the plant conditions (size and pressure rating of the pipeline, medium temperature etc.).
- Check any mounted pressure gauges to make sure they function.

5 Mounting and start-up

5.1 Mounting orientation

Standard mounting position

- ➔ Install the regulator in a horizontal pipeline with the set point adjuster (10) facing downward (see Fig. 2 and Fig. 3).

The regulator in valve sizes DN 15 to 25 can also be installed in vertical pipes.

Installation conditions

- Make sure that the regulator remains freely accessible after the plant has been completed.
- Install a strainer upstream of the regulator (see section 5.2).

- The direction of flow must match the direction indicated by the arrow on the body.
- Connect external control lines at the side of the main pipe (see Fig. 6)
- Install the regulator free of stress.

NOTICE

Possible malfunction and damage due to adverse weather conditions (temperature, humidity).

- Do not install the device outdoors or in rooms prone to frost.
- Protect the regulator against frost if it is used to control freezing media.
- Either heat the regulator or remove it from the plant and completely drain the residual medium.

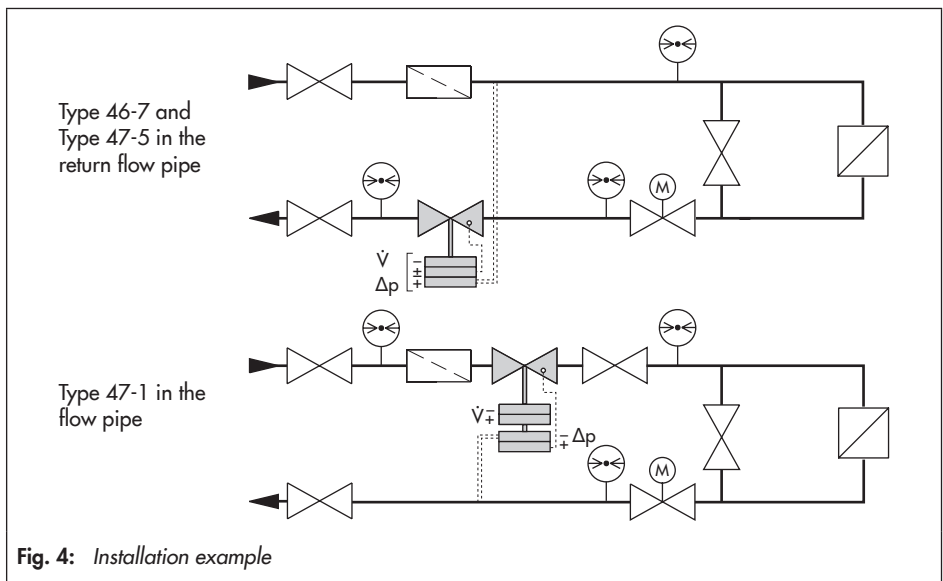

Fig. 4: Installation example

5.2 Additional fittings

Strainer

A strainer installed upstream in the flow pipe holds back any dirt or other foreign particles carried along by the medium. For example, the SAMSON Type 1 NI Strainer is suitable (▶ T 1010).

- Do not use the strainer to permanently filter the process medium.
- Install the strainer upstream of the regulator.
- The direction of flow must correspond to the arrow on the valve body.
- The filter element must be installed to hang downward.
- Allow sufficient space to remove the filter.

Shut-off valve

Install a hand-operated shut-off valve both upstream of the strainer and at the outlet of the return flow pipe (see Fig. 4). This allows the plant to be shut down for cleaning and maintenance, and when the plant is not used for longer periods of time.

Pressure gauge

Install a pressure gauge at a suitable point to monitor the pressures prevailing in the plant (see Fig. 4).

Control line

Depending on the regulator version, a control line (standard: 6x1 mm pipe diameter) must be adapted and mounted on site. Make sure that the control line is free of dirt.

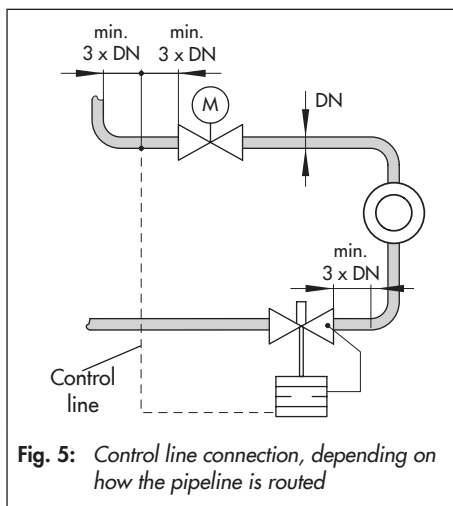

Fig. 5: Control line connection, depending on how the pipeline is routed

We recommend installing the control line for tapping pressure from the pipeline at a distance of at least three times the nominal size (DN) away from any pipe fittings (e.g. manifolds, bends, branches or other valves), that may cause turbulence in the flow.

How the lines are routed generally depends on the installation site. Preferably connect the control line to the side of the main pipe.

- Do not change the pipe diameter of the main pipeline with an eccentric reducer.
- Refer to installation schematics (Fig. 4) for line routing.

5.3 Putting the regulator into operation

- Do not start up the regulator until all parts have been mounted.
- Make sure the control lines are open and correctly connected.

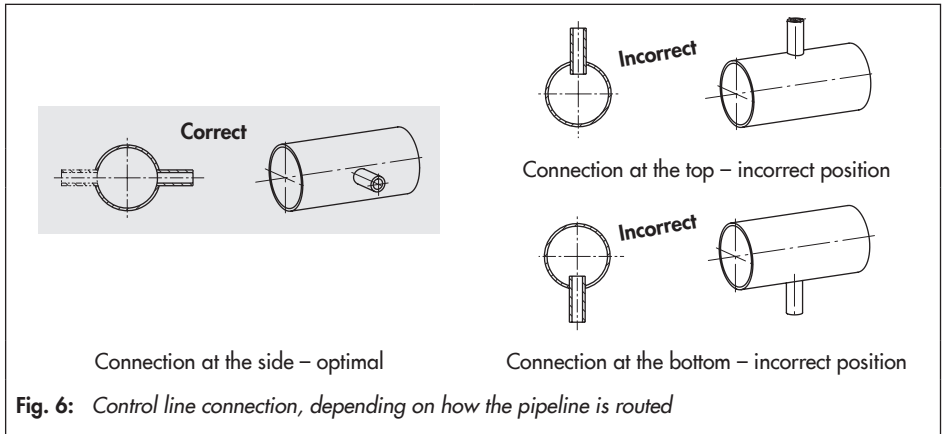

- ➔ Make sure that the restriction (1.2) is open while filling the plant. Turn the set point screw (17) counterclockwise (⤵) as far as it will go.
- ➔ Open the shut-off valves slowly over a time period of several minutes starting from the upstream pressure side. Afterwards, open all the valves on the consumer side (downstream of the regulator).

NOTICE

Risk of valve damage due to a sudden pressure increase and resulting high flow velocities.

Slowly open the shut-off valve in the pipeline during start-up.

Pressure testing the plant

All plant components must be designed for the test pressure. Remove the regulator from the pipeline, if necessary.

NOTICE

Risk of damage to the diaphragm actuator due to impermissible excess pressure.

The test pressure must not exceed the nominal pressure at the actuator by 1.5 times on testing the pressure of the plant when the regulator is already installed.

Rinsing the plant

1. After filling the plant, first completely open the consumer
2. Adjust the maximum flow rate at the regulator (see section 6.1.1).
3. Adjust the maximum differential pressure at the regulator (see section 6.1.2).
4. Rinse out the pipeline at full flow rate for several minutes.
5. Check the strainer (e.g. measure the pressure drop) and clean it, if necessary.

6 Operation

6.1 Adjusting the set points

6.1.1 Flow control

- **Type 46-7 and Type 47-1:** Adjust the maximum differential pressure at the regulator (see section 6.1.2).
- Completely open the control and shut-off valves or a bypass valve in the plant.
1. To fully load the set point spring (8), turn the set point adjuster (10) or manual adjuster (19) clockwise (↻) as far as it will go.
 2. Unscrew the cap (18).
 3. Undo the lock nut (16).
 4. Use a suitable tool (Allen key, SW 4) to turn the set point screw (17) clockwise (↻) as far as it will go to close the restriction (1.2).
 5. Refer to Fig. 8 to find out how many turns are required to set the flow rate.
 6. Use a suitable tool (Allen key, SW 4) to turn the set point screw (17) by the required number of turns. Turn it counter-clockwise (↺) to open the restriction. The flow rate rises.

 **Tip**

For exact adjustment, verify adjusted value with a heat or flow meter.

7. Secure restriction setting using the lock nut (16) at the set point screw (17). Screw cap (18) back on.
8. Lead-seal the set point setting at set point screw (17) and cap (18).

i Note

The set point can be directly adjusted in the version with manual adjuster. One scale division corresponds to one turn of the set point screw.

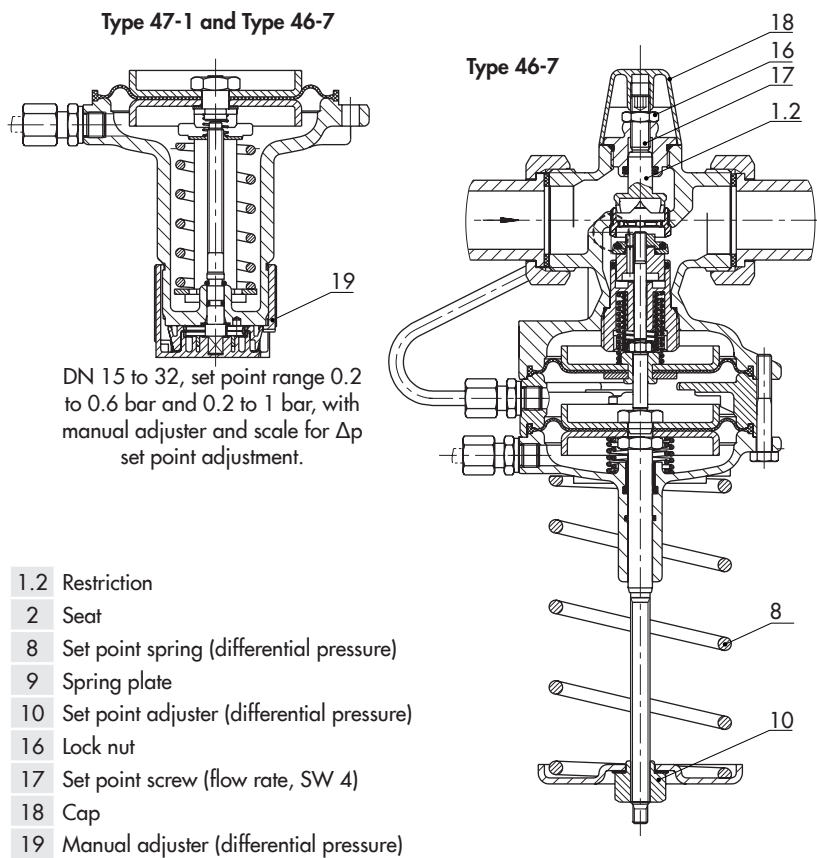

Fig. 7: Flow rate and differential pressure control using Type 46-7 and Type 47-1

Table 6: Flow rate set point range for water in m³/h

Valve size DN	15				20	25	32	40 ¹⁾	50 ¹⁾
K_{V5} coefficient	0.4	1	2.5	4	6.3	8	12.5	16/20 ²⁾	20/25 ²⁾
Set point range in m ³ /h with 0.2 bar diff. pressure at restriction	-			0.6 to 1.3 ³⁾	0.8 to 2.3 ³⁾	0.8 to 3.5 ³⁾	2 to 5.8 ³⁾	3 to 9.1 ³⁾	4 to 14.1 ³⁾
$\Delta p_{\text{restriction}}$	0.01 to 0.2	0.12 to 0.64	0.2 to 1.2	0.6 to 2.5	0.8 to 3.6	0.8 to 4.2 ⁴⁾	2 to 10	3 to 12.5	4 to 15

1) Also as version with flanged valve body

2) K_{V5} coefficient with flanged valve body

3) An increase in noise level can be expected when the specified flow rates are exceeded.

4) 5 m³/h with $\Delta p_{\text{restriction}} = 0.3$ bar (special version)

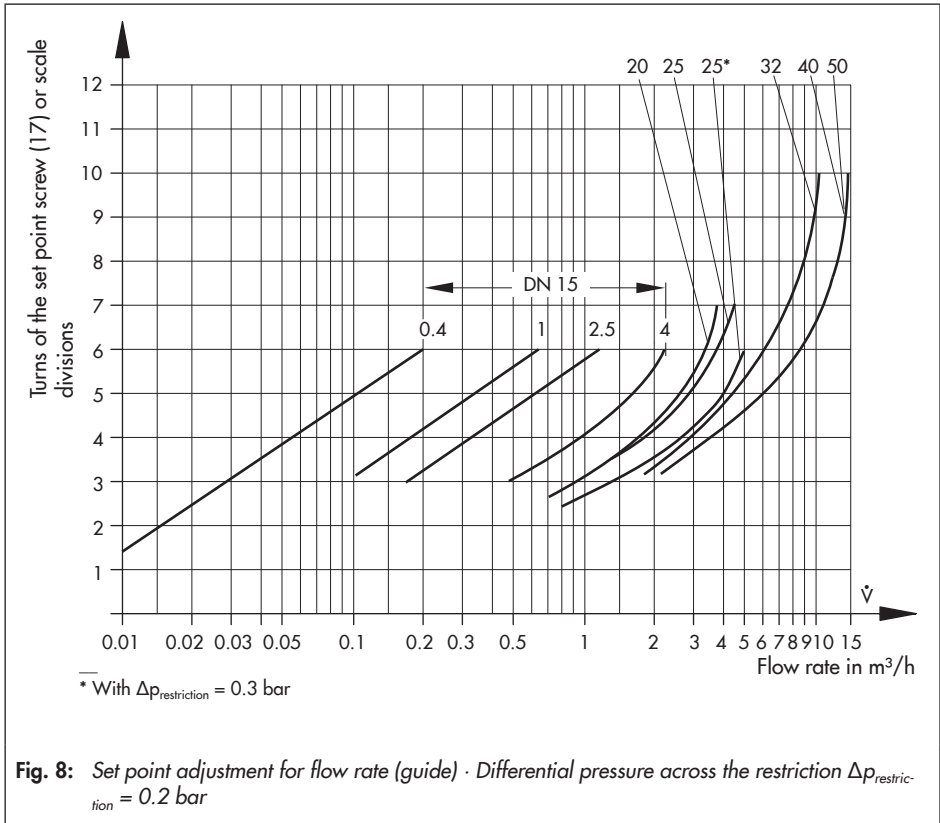

6.1.2 Differential pressure control

i Note

The differential pressure can only be adjusted on the Type 46-7 and Type 47-1 Regulators. The differential pressure of the Type 47-5 Regulator is fixed.

1. Close the shut-off valves or the bypass to reduce the maximum flow rate to approx. 5 to 10 %.

If you are using a motorized valve, close it to approx. 10 % of its travel.

2. Adjust the required differential pressure at the set point adjuster (10).

Turn clockwise (↻) to load the set point spring (8). The Δp set point increases.

Turn counterclockwise (↺) to relieve the tension from the set point spring (8). The Δp set point is reduced.

The set point spring is installed in the bottom section of the housing in DN 15 to 32. The set point spring is located externally in the DN 40 and 50 versions (see Fig. 8). The set point can be continuously adjusted using the set point adjuster according to the value on the scale (see Fig. 9).

i Note

The maximum value on the scale of the set point adjuster is 8. However, the maximum set point is reached earlier (see Fig. 9).

One turn of the set point adjuster will change the differential pressure by approx.

0.033 bar in the range from 0.2 to 1 bar and by approx. 0.02 bar in the range from 0.2 to 0.6 bar.

! NOTICE

Risk of regulator malfunction due to incorrect setting.

A scale value below 1 may lead to incorrect control.

Only adjust values above 1 on the scale.

If the setting is incorrect (value on the scale below 1), proceed as follows:

- Depressurize the regulator.
- Turn the set point adjuster counterclockwise (↺) as far as it will go (minimum setting).
- Turn the set point adjuster back clockwise to a value between 1 to 2 on the scale.

The set point can now be adjusted.

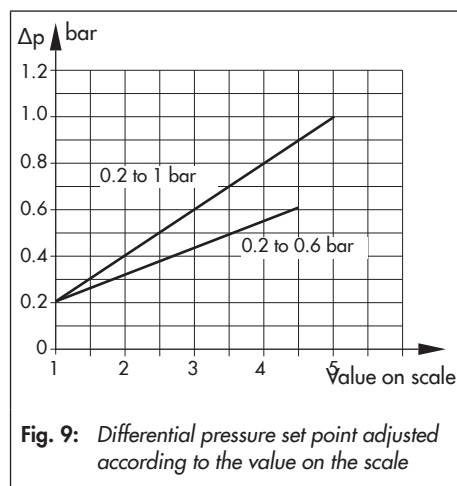

Fig. 9: Differential pressure set point adjusted according to the value on the scale

7 Servicing

The regulator does not require much maintenance. Nevertheless, it is subject to natural wear, particularly at the seat, plug and operating diaphragm. Depending on the operating conditions, check the regulator at regular intervals to avoid possible malfunctions.



Tip

SAMSON's After-sales Service can support you in drawing up an inspection and test plan for your plant.



DANGER

Risk of bursting in pressure equipment.

Regulators and pipelines are pressure equipment. Improper opening can lead to device components bursting.

- Before starting any work on the device, depressurize all plant sections affected as well as the regulator.
- Drain the process medium from all the plant sections affected as well as the regulator.
- If necessary, a suitable overpressure protection must be installed on site in the plant section.
- Wear personal protective equipment.



WARNING

Risk of personal injury due to residual process medium in the regulator.

While working on the regulator, residual process medium can escape and, depending on its properties, may lead to personal injury, e.g. (chemical) burns.

- If possible, drain the process medium from all the plant sections affected and the regulator.
- Wear protective clothing, safety gloves and eye protection.



WARNING

Risk of burn injuries due to hot or cold components and pipelines.

Depending on the process medium, regulator components and pipelines may get very hot or cold and cause burn injuries.

- Allow components and pipelines to cool down or warm up to the ambient temperature.
- Wear protective clothing and safety gloves.



NOTICE

Risk of regulator damage due to incorrect servicing or repair.

Only allow trained staff to perform service and repair work.

! NOTICE***Risk of regulator damage due to excessively high or low tightening torques.***

Observe the specified torques when tightening regulator components. Excessive tightening torques lead to parts wearing out more quickly. Parts that are too loose may cause leakage.

Observe the tightening torques specified in section 7.3.

i Note

The regulator was checked by SAMSON before delivery.

- The product warranty becomes void if service or repair work not described in these instructions is performed without prior agreement by SAMSON's After-sales Service.*
 - Only use original spare parts by SAMSON, which comply with the original specifications.*
-

7.1 Cleaning and replacing the plug

See Fig. 2 and Fig. 3.

Disassembly

1. Put the regulator out of operation (see section 9.1).
2. For **Type 46-7 and Type 47-1**, completely relieve the tension from the set point spring (8) by turning the set point adjuster (10) or manual adjuster (19) counter-clockwise (↺).
3. Unscrew the screws (15) and lift the actuator off the valve body.
4. Pull the valve spring (5), if installed, out of the body.
5. **DN 15 to 25:** unscrew and pull out the guide nipple with plug (3) using a socket wrench (order no. 1280-3001).
DN 32 to 50: unscrew the stopper (25) at the plug and pull out the plug.
6. Clean the seat and plug thoroughly. Check the control lines for any blockages. If the plug is damaged, replace the entire plug with a new one.

Assembly

1. Insert cleaned or new plug.
2. **DN 15 to 25:** tighten the guide nipple with plug (3) using a socket wrench (order no. 1280-3001). Observe the tightening torques specified in section 7.3.
DN 32 to 50: insert the plug followed by the stopper (25) of the plug. Observe the tightening torques specified in section 7.3.
3. Insert the valve spring (5), if installed, into the body.
4. Place the actuator on the body. Tighten screws (15). Observe the tightening torques specified in section 7.3.
5. Fasten the control lines (11, 12).
6. Install the regulator into the pipeline.
7. Fasten the external control lines (13, 14).
8. Put the regulator into operation (see section 5.3).

7.2 Replacing the diaphragm

i Note

The diaphragm in some versions can only be replaced together with the diaphragm plate.

See Fig. 2 and Fig. 3.

Version without manual adjuster

Disassembly

1. Put the regulator out of operation (see section 9.1).
2. For **Type 46-7** and **Type 47-1**, completely relieve the tension from the set point spring (8) by turning counterclockwise (↺).
3. Remove the bolts (15).
4. Remove the intermediate ring (7), bottom diaphragm case and actuator stems (6.2 and 6.4), diaphragms (6.1 and 6.3) and diaphragm plate one after the other from the regulator.
5. Pull the valve spring (5), if installed, out of the body.
6. Replace damaged diaphragms. Observe the tightening torques specified in section 7.3.

Assembly

1. Mount the diaphragm plate, new diaphragms (6.1 and 6.3), the actuator stems (6.2 and 6.4), bottom diaphragm case and intermediate ring (7).
2. Insert the valve spring (5), if installed, into the body.
3. Tighten screws (15). Observe the tightening torques specified in section 7.3.
4. Fasten the control lines (11, 12).
5. Install the regulator into the pipeline.
6. Fasten the external control lines (13, 14).
7. Put the regulator into operation (see section 5.3).

Servicing

Version with manual adjuster

Disassembly

1. Put the regulator out of operation (see section 9.1).
2. To completely relieve the tension from the set point springs (8), turn the manual adjuster (19) counterclockwise (↺) until you hear it a clicking noise.
3. Remove the bolts (15).
4. Remove the bottom section of the body (22), intermediate ring (7) and top diaphragm (6.3) together with diaphragm plates and the actuator stem (6.4) from the regulator.
5. Pull the valve spring (5), if installed, out of the body.

If the bottom diaphragm (6.1) is damaged, proceed as follows:

6. Unscrew the assembly, consisting of diaphragm (6.1) together the diaphragm plates, set point spring (8) and support (21), from the spindle (20) by turning the assembly counterclockwise. Pull it out the bottom section of the valve body.
7. Replace the assembly.

Assembly

1. Push the assembly, consisting of the new diaphragm (6.1) together the diaphragm plates, set point spring (8) and support (21), over the spindle (20) into the bottom section (22) of the valve body.
2. Turn the assembly clockwise (↻) by one turn to screw it onto the spindle (20).
Lift the diaphragm plate to check whether the thread of the spring plate (23) has engaged. Turn the assembly one turn further, if necessary.
3. Insert the valve spring (5), if installed, into the body.
4. Mount the bottom section of the body (22), intermediate ring (7) and top diaphragm (6.3) together with diaphragm plates and the actuator stem (6.4).
5. Tighten screws (15). Observe the tightening torques specified in section 7.3.
6. Fasten the control lines (11, 12).
7. Install the regulator into the pipeline.
8. Fasten the external control lines (13, 14).
9. Put the regulator into operation (see section 5.3).

7.3 Tightening torques

Component	DN	Tightening torque in Nm
Plug (3)	15 to 25 32 to 50	70 110
Screws (15)	15 to 32 40 to 50	8 18
Diaphragm nut	15 to 50	22

7.4 Preparation for return shipment

Defective devices can be returned to SAMSON for repair. Proceed as follows to return devices to SAMSON:

1. Put the regulator out of operation (see section 9).
2. Decontaminate the regulator. Remove any residual process medium.
3. Fill in the Declaration on Contamination. The declaration form can be downloaded from our website at
 ▶ www.samsongroup.com > Service & Support > After-sales Service > Returning goods.
4. Continue as described on our website at
 ▶ www.samsongroup.com > Service & Support > After-sales Service > Returning goods.

7.5 Ordering spare parts and operating supplies

Contact your nearest SAMSON subsidiary or SAMSON's After-sales Service for information on spare parts, lubricants and tools.

8 Malfunctions

The malfunctions listed in Table 7 are caused by mechanical faults and incorrect regulator sizing. In the simplest case, the functioning can be restored following the recommended action. Special tools may be required for repair work.

Exceptional operating and installation conditions may lead to changed situations that may affect the control response and lead to malfunctions. For troubleshooting, the conditions, such as installation, process medium, temperature and pressure conditions, must be taken into account.

SAMSON's After-sales Service can help during troubleshooting. Further information is available in section 10.1.

i Note

Contact SAMSON's After-sales Service for malfunctions not listed in the table and when the malfunction cannot be remedied as described.

Table 7: Troubleshooting

Malfunction	Possible reasons	Recommended action
Flow rate or differential pressure exceeds adjusted set point	Insufficient pressure pulses on the operating diaphragm.	→ Clean the control line and screw fittings.
	Foreign particles blocking the plug	→ Remove foreign particles. → Replace damaged parts. → Contact SAMSON's After-sales Service.
	Seat and plug are worn or leak.	→ Replace the damaged seat and plug. → Contact SAMSON's After-sales Service.
	Valve too large for control task (flow rate) or too small (differential pressure)	→ Check the sizing. → Change K_{VS}/C_V coefficient, if necessary or install a different sized regulator. → Contact SAMSON's After-sales Service.
	Defective operating diaphragm	→ Replace damaged diaphragm.
	Seat and plug are worn or leak.	→ Clean the seat and plug. → Replace the damaged seat and plug. → Contact SAMSON's After-sales Service.
	A safety device (e.g. STL or STM) has been triggered.	→ Check plant. Unlock safety device (where necessary).
Flow or differential pressure set point not reached	Regulator installed against the flow.	→ Install the regulator so that the direction of flow matches the direction indicated by the arrow on the body.
	Regulator or K_{VS}/C_V coefficient too small	→ Check the sizing. → Change K_{VS}/C_V coefficient, if necessary or install a different sized regulator. → Contact SAMSON's After-sales Service.
	Incorrect set point range selected.	→ Check set point range → Contact SAMSON's After-sales Service.
	Safety device, e.g. pressure limiter, has been triggered.	→ Check plant. If necessary, unlock safety device.
	Plant differential pressure Δp too low.	→ Compare differential pressure in the plant with the plant's drag. Differential pressure across the plant: $\Delta p_{\min} = \Delta p_{\text{restriction}} + (V/K_{VS})^2$
Flow or differential pressure set point not reached	Foreign particles blocking the plug	→ Remove foreign particles. → Replace damaged parts. → Contact SAMSON's After-sales Service.
	Control line blocked	→ Clean the control line and screw fittings.
	Strainer blocked.	→ Clean the strainer.

Malfunction	Possible reasons	Recommended action
Control loop hunts.	Regulator or K_{vs}/C_v coefficient too large	<ul style="list-style-type: none"> → Check the sizing. → Change K_{vs}/C_v coefficient, if necessary or install a different sized regulator. → Contact SAMSON's After-sales Service.
	The restriction in the control line for pressure tapping is too large or missing.	<ul style="list-style-type: none"> → Install a restriction. → Install a smaller restriction.
Slow control response	Restriction in the screw joint of the actuator dirty or too small.	→ Clean screw joint or install larger screw joint.
	Dirt in the control line.	→ Clean the control line.
Jerky control response	Increased friction, e.g. due to foreign particles between seat and plug.	<ul style="list-style-type: none"> → Remove foreign particles. → Replace damaged parts. → Contact SAMSON's After-sales Service.
Loud noises	High flow velocity, cavitation.	<ul style="list-style-type: none"> → Check the sizing. → Install larger regulator, if necessary.
Leakage at the actuator	Defective operating diaphragm	→ Replace damaged diaphragm.

i Note

Contact SAMSON's After-sales Service for malfunctions not listed in the table and when the malfunction cannot be remedied as described.

9 Decommissioning and removal

⚠ DANGER

Risk of bursting in pressure equipment.

Regulators and pipelines are pressure equipment. Improper opening can lead to bursting of the valve.

- Before starting any work on the regulator, depressurize all plant sections affected as well as the control line.
- Drain the process medium from all the plant sections affected as well as the regulator.
- Wear personal protective equipment.

⚠ WARNING

Risk of personal injury due to residual process medium in the regulator and control line.

While working on the regulator and control line, residual process medium can escape and, depending on its properties, may lead to personal injury, e.g. (chemical) burns. Wear protective clothing, safety gloves and eye protection.

⚠ WARNING

Risk of burn injuries due to hot or cold components and pipeline.

Regulator components and the pipeline may become very hot or cold. Risk of burn injuries.

- Allow components and pipelines to cool down or warm up to the ambient temperature.
- Wear protective clothing and safety gloves.

9.1 Decommissioning

To decommission the regulator for service and repair work or disassembly, proceed as follows:

1. Close the shut-off valve on the upstream side of the regulator.
2. Close the shut-off valve on the downstream side of the regulator.
3. If necessary, allow the pipeline and regulator to cool down or warm up to the ambient temperature.
4. Depressurize the plant sections connected through the control line.
5. Unscrew the control line.
6. Completely drain the pipelines and regulator.
7. Remove the regulator from the pipeline.

9.2 Disposal



SAMSON is a producer registered at the following European institution

► <https://www.ewrn.org/national-registers/national-registers>.

WEEE reg. no.:
DE 62194439/FR 025665

- ➔ Observe local, national and international refuse regulations.
- ➔ Do not dispose of components, lubricants and hazardous substances together with your other household waste.

i Note

We can provide you with a recycling passport according to PAS 1049 on request. Simply e-mail us at aftersaleservice@samsongroup.com giving details of your company address.

💡 Tip

On request, we can appoint a service provider to dismantle and recycle the product as part of a distributor take-back scheme.

10 Annex

10.1 After-sales service

Contact SAMSON's After-sales Service for support concerning service or repair work or when malfunctions or defects arise.

E-mail address

You can reach our after-sales service at aftersaleservice@samsongroup.com.

Addresses of SAMSON AG and its subsidiaries

The addresses of SAMSON, its subsidiaries, representatives and service facilities worldwide can be found on our website (► www.samsongroup.com) or in all SAMSON product catalogs.

To assist diagnosis and in case of an unclear mounting situation, specify the following details (so far as possible). See section 2:

- Device type and valve size
- Model number and configuration ID
- Upstream and downstream pressure
- Temperature and process medium
- Min. and max. flow rate
- Is a strainer installed?
- Installation drawing showing the exact location of the regulator and all the additionally installed components (shut-off valves, pressure gauge etc.)

11 Certificates

The EU declarations of conformity are included on the next pages.

EU DECLARATION OF CONFORMITY
TRANSLATION



Module A

For the following products, SAMSON hereby declares under its sole responsibility:

Devices	Series	Type	Version	
Self-operated Regulators	43	2432	DIN EN, body, CC499K and EN-GJS-400-18-LT, DN 50, PN 25, fluids G2, L2, L1 ¹⁾	
	43	2436	DIN EN, body, CC499K and EN-GJS-400-18-LT, DN 50, PN 25, fluids G2, L2, L1 ¹⁾	
	43	2437	DIN EN, body, CC499K and EN-GJS-400-18-LT, DN 50, PN 25, fluids G2, L2, L1 ¹⁾	
	---	2111	DIN EN, body, 1.0619 and 1.4408, DN 40-50, PN 40, fluids G2, L2, L1 ¹⁾ DIN EN, body, EN-GJS-400-18-LT, DN 50, PN 25, fluids G2, L2, L1 ¹⁾ ANSI, body, A216 WCC and A351 CF8M, NPS 1½-2, Class 300, fluids G2, L2, L1 ¹⁾	
Three-way valve	---	2119	DIN EN, body, EN-GJL-250 and 1.0619, DN 65-125, PN 16, fluids G2, L2, L1 ¹⁾	
			DIN EN, body, 1.0619, DN 50-80, PN 25, fluids G2, L2, L1 ¹⁾	
			DIN EN, body, 1.0619 and 1.4408, DN 40-50, PN 40, fluids G2, L2, L1 ¹⁾	
			ANSI, body, A216 WCC and A351 CF8M, NPS 2½-4, Class 150, fluids G2, L2, L1 ¹⁾ ANSI, body, A216 WCC and A351 CF8M, NPS 1½, Class 300, fluids G2, L2, L1 ¹⁾	
Control valve	---	3222	DIN EN, body, EN-GJS-400-18-LT, DN 50, PN 25, fluids G2, L2, L1 ¹⁾ DIN EN, body, CC499K, DN 32-40, PN 25, all fluids	
Three-way valve	---	3226	DIN EN, body, CC499K, DN 50, PN 25, fluids G2, L2 ²⁾	
Three-way valve	---	3260	DIN EN, body, EN-GJL-250, DN 65-200, PN 16, fluids G2, L2 ²⁾	
Globe valve Three-way valve	V2001	3531	DIN EN, body, EN-GJS-400-18-LT, DN 50-80, PN 25, fluids G2, L2, L1 ¹⁾	
		3535	DIN EN, body, 1.0619 and 1.4408, DN 32-40, PN 25, all fluids ANSI, body, A216 WCC and A351 CF8M, NPS 1½-2, Class 150, all fluids	
Control valve	---	3214	DIN EN, body, EN-GJL-250, DN 65-125, PN 16, fluids G2, L2, L1 ¹⁾	
			DIN EN, body, EN-GJS-400-18-LT, DN 50-80, PN 25, fluids G2, L2, L1 ¹⁾	
			ANSI, body, A126 B, NPS 3-4, Class 125, fluids G2, L2, L1 ¹⁾	
			ANSI, body, A216 WCC and A351 CF8M, NPS 1½-2, Class 150, all fluids	
Self-operated Regulators	42	2423	DIN EN, body, EN-GJL-250 and EN-GJS-400-18-LT, DN 65-125, PN 16, fluids G2, L2, L1 ¹⁾	
			DIN EN, body, EN-GJS-416-LT, DN 50-80, PN 25, fluids G2, L2, L1 ¹⁾	
			DIN EN, body, 1.0619 and 1.4408, DN 32-50, PN 16, all fluids	
			DIN EN, body, 1.0619 and 1.4408, DN 32-40, PN 25, all fluids ANSI, body, A126 B, NPS 3-4, Class 125, fluids G2, L2, L1 ¹⁾	
	42	2422	DIN EN, body, EN-GJL-250 and EN-GJS-400-18-LT, DN 65-125, PN 16, fluids G2, L2, L1 ¹⁾	
			DIN EN, body, EN-GJS-400-18-LT, DN 50-80, PN 25, fluids G2, L2, L1 ¹⁾	
			DIN EN, body, 1.0619, 1.4408 and 1.6220+QT, DN 32-50, PN 16, all fluids	
			ANSI, body, A126 B, NPS 3-4, Class 125, fluids G2, L2, L1 ¹⁾ ANSI, body, A216 WCC, A351 CF8M and A352 LCC, NPS 1½-2, Class 150, all fluids	
Strainers	1N/1NI	2601	DIN EN, body, CB752S, G 2 (DN50), PN25, fluids G2, L2 ²⁾	
Strainers	2N/2NI	2602	DIN EN, body, EN-GJL-250, DN 200-250, PN 10, fluids G2, L2, L1 ¹⁾	
			DIN EN, body, EN-GJL-250, DN 65-125, PN 16, fluids G2, L2, L1 ¹⁾	
			DIN EN, body, EN-GJS-400-18-LT, DN 100-125, PN 16, fluids G2, L2, L1 ¹⁾	
			DIN EN, body, EN-GJS-400-18-LT, DN 50-80, PN 25, fluids G2, L2, L1 ¹⁾ DIN EN, body, 1.4408, DN 32-50, PN 16, all fluids	
Self-operated Regulators	---	2373/2375	ANSI, body, A995 4A and A995 5A, NPS 1½-2, Class 150, all fluids	
		2440 (44-0B) 2441 (44-1B) 2446 (44-6B)	DIN EN, body, EN-GJS-400-18-LT, DN 50, PN 25, fluids G2, L2, L1 ¹⁾	
	44	2442 (44-2) 2443 (44-3) 2444 (44-4) 2447 (44-7) 2448 (44-8) 2449 (44-9)		DIN EN, body, EN-GJS-400-18-LT and CC499K, DN 50, PN 25, fluids G2, L2, L1 ¹⁾

Revision 00

EU DECLARATION OF CONFORMITY
TRANSLATION



Devices	Series	Type	Version
Self-operated Regulators	45	2451 (45-1)	DIN EN, body, EN-GJS-400-18-LT and CC499K, DN 50, PN 25, fluids G2, L2, L1 ¹⁾
		2452 (45-2)	
		2453 (45-3)	
		2454 (45-4)	
		2455 (45-5)	
	46	2465 (46-5)	DIN EN, body, EN-GJS-400-18-LT and CC499K, DN 50, PN 25, fluids G2, L2, L1 ¹⁾
		2466 (46-6)	
		2467 (46-7)	
		2469 (46-9)	
	47	2471 (47-1)	DIN EN, body, EN-GJS-400-18-LT and CC499K, DN 50, PN 25, fluids G2, L2, L1 ¹⁾
		2474 (47-4)	
		2475 (47-5)	
		2479 (47-9)	
	48	2488	DIN EN, body, EN-GJS-400-18-LT and CC499K, DN 50, PN 25, fluids G2, L2, L1 ¹⁾
		2489	
	40	2405	DIN EN, body, EN-GJS-400-18-LT, DN 50, PN 25, fluids G2, L2, L1 ¹⁾
			ANSI, body, A216 WCC and A351 CF8M, NPS 1½-2, Class 150, all fluids
		2406	DIN EN, body, EN-GJL-250, DN 65-125, PN 16, fluids G2, L2, L1 ¹⁾
			DIN EN, body, EN-GJS-400-18-LT, DN 50, PN 25, fluids G2, L2, L1 ¹⁾
			ANSI, body, A126 B, NPS 3-4, Class 125, fluids G2, L2, L1 ¹⁾
			ANSI, body, A216 WCC and A351 CF8M, NPS 1½-2, Class 150, all fluids
	41	2412	DIN EN, body, EN-GJL-250, DN 65-100, PN 16, fluids G2, L2, L1 ¹⁾
			DIN EN, body, EN-GJS-400-18-LT, DN 50-80, PN 25, fluids G2, L2, L1 ¹⁾
		2417	ANSI, body, A126 B, NPS 3-4, Class 125, fluids G2, L2, L1 ¹⁾
			ANSI, body, A216 WCC and A351 CF8M, NPS 1½-2, Class 150, all fluids
	42	2421 RS	DIN EN, body, 1.0619, 1.4408, 1.4571 and 1.4401/1.4404, DN 32-50, PN 16, all fluids
			DIN EN, body, 1.0619, 1.4408, 1.4571 and 1.4401/1.4404, DN 32-40, PN 25, all fluids
			ANSI, body, A216 WCC, A351 CF8M and A182 F316/A182 F316L, NPS 1½-2, Class 150, all fluids
---	2331 2337	DIN EN, body, EN-GJL-250, DN 65-200, PN 16, fluids G2, L2 ²⁾	
		DIN EN, body, EN-GJS-400-18-LT, DN 65-150, PN 16, fluids G2, L2 ²⁾	
		DIN EN, body, EN-GJS-400-18-LT, DN 65-125, PN 25, fluids G2, L2 ²⁾	
		DIN EN, body 1.0619, DN 65-200, PN 16, fluids G2, L2 ²⁾	
		DIN EN, body 1.0619, DN 65-100, PN 40, fluids G2, L2 ²⁾	
---	2333 2335	DIN EN, body, EN-GJL-250, DN 65-125, PN 16, fluids G2, L2, L1 ¹⁾	
		DIN EN, body, EN-GJS-400-18-LT, DN 65-80, PN 25, fluids G2, L2, L1 ¹⁾	
		ANSI, body, A126 B, NPS 3-4, Class 125, fluids G2, L2, L1 ¹⁾	
---	2334	DIN EN, body, EN-GJL-250, DN 65-125, PN 16, fluids G2, L2, L1 ¹⁾	
		DIN EN, body, EN-GJS-400-18-LT, DN 65-125, PN 16, fluids G2, L2, L1 ¹⁾	
		DIN EN, body, EN-GJS-400-18-LT, DN 65-80, PN 25, fluids G2, L2, L1 ¹⁾	
		ANSI, body, A126 B, NPS 3-4, Class 125, fluids G2, L2, L1 ¹⁾	
---	2404-1	DIN EN, body, EN-GJL-250, DN 65-125, PN16, fluids G2, L2, L1 ¹⁾	
		ANSI, body, A126 B, NPS 3-4, Class 125, fluids G2, L2, L1 ¹⁾	
---	2404-2	ANSI, body, A216 WCC und A351 CF8M, NPS 1½-2, Class 150, all fluids	
		DIN EN, body, EN-GJL-250, DN 65-125, PN 16, fluids G2, L2, L1 ¹⁾	
		ANSI, body, A126 B, NPS 3-4, Class 125, fluids G2, L2, L1 ¹⁾	

¹⁾ Gases according to Article 4(1)(c.i), second indent
Liquids according to Article 4(1)(c.ii)

²⁾ Gases according to Article 4(1)(c.i), second indent
Liquids according to Article 4(1)(c.ii), second indent

Revision 00

EU DECLARATION OF CONFORMITY
TRANSLATION



That the products mentioned above comply with the requirements of the following standards:

Directive of the European Parliament and of the Council on the harmonization of the laws of the Member States relating to the making available on the market of pressure equipment	2014/68/EU	of 15. May 2014
Applied conformity assessment procedure for fluids according to Article 4(1)	Module A	

Technical standards applied: DIN EN 12516-2, DIN EN 12516-3, ASME B16.34

Manufacturer: SAMSON AG, Weismüllerstraße 3, 60314 Frankfurt am Main, Germany

Frankfurt am Main, 26. August 2022

ppa. Norbert Tollas
Senior Vice President
Global Operations

i.V. Peter Scheermesser
Director
Product Maintenance & Engineered Products

Revision 00

EB 3131 EN



SAMSON AKTIENGESELLSCHAFT
Weismüllerstraße 3 · 60314 Frankfurt am Main, Germany
Phone: +49 69 4009-0 · Fax: +49 69 4009-1507
samson@samsongroup.com · www.samsongroup.com