

MOUNTING AND OPERATING INSTRUCTIONS

The SAMSON logo consists of the word "SAMSON" in a bold, white, sans-serif font, centered within a solid black circle. This circle is itself centered within a white square frame.

EB 3013 EN

Translation of original instructions



Type 42-34 Differential Pressure Regulator



Type 42-38 Differential Pressure Regulator

Differential Pressure Regulator with Flow Limitation

Type 42-34 · Type 42-38

Self-operated Regulators · Closing Actuator

Edition October 2023

A row of four certification marks: the UKCA mark (UK and CA), the CE mark, and the EAC mark.

Note on these mounting and operating instructions

These mounting and operating instructions assist you in mounting and operating the device safely. The instructions are binding for handling SAMSON devices. The images shown in these instructions are for illustration purposes only. The actual product may vary.

- For the safe and proper use of these instructions, read them carefully and keep them for later reference.
- If you have any questions about these instructions, contact SAMSON's After-sales Service (aftersaleservice@samsongroup.com).



The mounting and operating instructions for the devices are included in the scope of delivery. The latest documentation is available on our website at www.samsongroup.com > **Service & Support** > **Downloads** > **Documentation**.

Definition of signal words

DANGER

Hazardous situations which, if not avoided, will result in death or serious injury

WARNING

Hazardous situations which, if not avoided, could result in death or serious injury

NOTICE

Property damage message or malfunction

Note

Additional information

Tip

Recommended action

1	Safety instructions and measures	1-1
1.1	Notes on possible severe personal injury	1-4
1.2	Notes on possible personal injury	1-5
1.3	Notes on possible property damage	1-7
2	Markings on the device	2-1
2.1	Nameplates	2-1
2.2	Location of the nameplates	2-2
2.3	Material identification number	2-2
2.3.1	Type 2423 Valve	2-2
2.3.2	Type 2424 and Type 2428 Actuators	2-2
3	Design and principle of operation	3-1
3.1	Additional fittings	3-4
3.1.1	Versions	3-5
3.2	Technical data	3-6
4	Shipment and on-site transport	4-1
4.1	Accepting the delivered goods	4-1
4.2	Removing the packaging from the regulator	4-1
4.3	Transporting and lifting the regulator	4-2
4.3.1	Transporting the regulator	4-2
4.3.2	Lifting the regulator	4-3
4.4	Storing the regulator	4-4
5	Installation	5-1
5.1	Installation conditions	5-1
5.2	Preparation for installation	5-3
5.3	Installation	5-6
5.3.1	Installing the regulator	5-7
5.4	Testing the regulator	5-7
5.4.1	Leak test	5-8
5.4.2	Pressure test	5-9
5.4.3	Filling the plant	5-10
5.4.4	Cleaning the pipeline	5-10
5.5	Insulation	5-11
6	Start-up	6-1
6.1	Start-up and putting the device back into operation	6-1
6.2	Starting up the plant	6-2

Contents

7	Operation	7-1
7.1	Adjusting the set points.....	7-1
7.1.1	Adjusting the differential pressure set point	7-1
7.1.2	Adjusting the flow limitation.....	7-3
7.1.3	Based on a known plant pressure drop	7-4
7.1.4	Based on an <u>unknown</u> plant pressure drop.....	7-4
7.2	Pressure conditions in the plant and at the regulator.....	7-5
7.3	Sample application	7-6
8	Malfunctions	8-1
8.1	Troubleshooting	8-1
8.2	Emergency action	8-3
9	Servicing.....	9-1
9.1	Preparing the valve for service work	9-6
9.2	Installing the regulator after service work	9-6
9.3	Service work.....	9-6
9.4	Replacing the actuator.....	9-6
9.5	Replacing the seat and plug.....	9-7
9.6	Exchanging the operating diaphragm unit in the actuator	9-7
9.6.1	Type 2428 Actuator	9-7
9.6.2	Type 2424 Actuator	9-7
9.7	Ordering spare parts and operating supplies	9-8
10	Decommissioning	10-1
11	Removal	11-1
11.1	Removing the regulator from the pipeline	11-1
11.2	Removing the actuator from the valve	11-1
12	Repairs	12-1
12.1	Returning devices to SAMSON	12-1
13	Disposal.....	13-1
14	Certificates	14-1
14.1	Information on the UK sales region.....	14-1
15	Annex.....	15-1
15.1	Tightening torques.....	15-1
15.2	Lubricants.....	15-1
15.3	Tools	15-1
15.4	Accessories	15-1
15.5	Spare parts	15-2
15.6	After-sales service	15-8

1 Safety instructions and measures

Intended use

The SAMSON Type 42-34 and Type 42-38 Regulators are designed as differential pressure regulators with flow limitation. They consist of a Type 2423 Valve and a Type 2424 Actuator (Type 42-34) or a Type 2428 Actuator (Type 42-38). These regulator components are delivered separately.

The self-operated regulators are used to control the differential pressure and limit the flow rate. They are mainly used in district heating supply networks with indirect connection and in industrial plants to control liquids.

The regulators are designed to operate under exactly defined conditions (e.g. operating pressure, process medium, temperature). Therefore, operators must ensure that the regulators are only used in operating conditions that meet the specifications used for sizing the devices at the ordering stage. In case operators intend to use the regulators in applications or conditions other than those specified, contact SAMSON.

SAMSON does not assume any liability for damage resulting from the failure to use the device for its intended purpose or for damage caused by external forces or any other external factors.

➔ Refer to the technical data and nameplate for limits and fields of application as well as possible uses.

Reasonably foreseeable misuse

The regulators are not suitable for the following applications:

- Use outside the limits defined during sizing and by the technical data
- Use outside the limits defined by the additional fittings mounted on the regulator

Furthermore, the following activities do not comply with the intended use:

- Use of non-original spare parts
- Performing service and repair work not described

Qualifications of operating personnel

The regulator must be mounted, started up, serviced and repaired by fully trained and qualified personnel only; the accepted industry codes and practices must be observed. According to these mounting and operating instructions, trained personnel refers to individuals who are able to judge the work they are assigned to and recognize possible hazards due to their specialized training, their knowledge and experience as well as their knowledge of the applicable standards.

Safety instructions and measures

Personal protective equipment

We recommend checking the hazards posed by the process medium being used (e.g.

▶ GESTIS (CLP) hazardous substances database). Depending on the process medium and/or the activity, the protective equipment required includes:

- Protective clothing, safety gloves and eye protection in applications with hot, cold and/or corrosive media
 - Wear hearing protection when working near the valve. Follow the instructions given by the plant operator.
 - Hard hat
 - Safety harness, e.g. when working at height
 - Safety footwear, if applicable ESD (electrostatic discharge) footwear
- ➔ Check with the plant operator for details on further protective equipment.

Revisions and other modifications

Revisions, conversions or other modifications of the product are not authorized by SAMSON. They are performed at the user's own risk and may lead to safety hazards, for example. Furthermore, the product may no longer meet the requirements for its intended use.

Warning against residual hazards

To avoid personal injury or property damage, plant operators and operating personnel must prevent hazards that could be caused in the regulator by the process medium, the operating pressure or by moving parts by taking appropriate precautions. Plant operators and operating personnel must observe all hazard statements, warnings and caution notes in these mounting and operating instructions.

Hazards resulting from the special working conditions at the installation site of the regulator must be identified in a risk assessment and prevented through the corresponding safety instructions drawn up by the operator.

We also recommend checking the hazards posed by the process medium being used (e.g.

▶ GESTIS (CLP) hazardous substances database).

- ➔ Observe safety measures for handling the device as well as fire prevention and explosion protection measures.

These mounting and operating instructions deals with the standard version of the device. Components of the device that differ to those used for the standard version described in this document can be exchanged with other certain SAMSON components. The residual hazards of these components are described in the associated mounting and operating instructions (see documents listed under 'Referenced documentation').

Safety features

The Types 42-34 and 42-38 Regulators do not have any special safety features. When relieved of pressure, the regulators are opened by the force of the set point springs.

Responsibilities of the operator

Operators are responsible for proper use and compliance with the safety regulations. Operators are obliged to provide these mounting and operating instructions as well as the referenced documents to the operating personnel and to instruct them in proper operation. Furthermore, operators must ensure that operating personnel or third parties are not exposed to any danger.

Operators are additionally responsible for ensuring that the limits for the product defined in the technical data are observed. This also applies to the start-up and shutdown procedures. Start-up and shutdown procedures fall within the scope of the operator's duties and, as such, are not part of these mounting and operating instructions. SAMSON is unable to make any statements about these procedures since the operative details (e.g. differential pressures and temperatures) vary in each individual case and are only known to the operator.

Responsibilities of operating personnel

Operating personnel must read and understand these mounting and operating instructions as well as the referenced documents and observe the specified hazard statements, warnings and caution notes. Furthermore, operating personnel must be familiar with the applicable health, safety and accident prevention regulations and comply with them.

Referenced standards, directives and regulations

The regulators comply with the requirements of the European Pressure Equipment Directive 2014/68/EU, Machinery Directive 2006/42/EC, Directive 2016 No. 1105 Pressure Equipment (Safety) Regulations 2016 and Directive 2008 No. 1597 Supply of Machinery (Safety) Regulations 2008. Regulators with a CE marking and/or UKCA marking have a declaration of conformity, which includes information about the applied conformity assessment procedure. The declaration of conformity is included in the 'Certificates' section.

According to the ignition hazard assessment performed in accordance with Clause 5.2 of ISO 80079-36, the non-electrical regulators do not have their own potential ignition source even in the rare incident of an operating fault. As a result, they do not fall within the scope of Directive 2014/34/EU.

→ For connection to the equipotential bonding system, observe the requirements specified in Clause 6.4 of EN 60079-14 (VDE 0165-1).

Safety instructions and measures

Referenced documentation

The following documents apply in addition to these mounting and operating instructions:

- Mounting and operating instructions for
e.g. **Type 2 N or 2 NI Strainer** ▶ EB 1015
- Data sheets for
e.g. **Accessories · Differential pressure and flow regulators** ▶ T 3095

- e.g. **Type 2 N or 2 NI Strainer** ▶ T 1015
- Mounting and operating instructions as well as data sheets for additional fittings (e.g. shut-off valves, pressure gauges etc.).

1.1 Notes on possible severe personal injury

DANGER

Risk of bursting in pressure equipment.

Regulators and pipelines are pressure equipment. Impermissible pressure or improper opening can lead to regulator components bursting.

- Observe the maximum permissible pressure for regulator and plant.
- If necessary, a suitable overpressure protection must be installed on site in the plant section.
- Before starting any work on the regulator, depressurize all plant sections affected as well as the regulator.
- Drain the process medium from all the plant sections affected as well as the regulator.
- Wear personal protective equipment.

1.2 Notes on possible personal injury

WARNING

Risk of personal injury through incorrect operation, use or installation as a result of information on the regulator being illegible.

Over time, markings, labels and nameplates on the regulator may become covered with dirt or become illegible in some other way. As a result, hazards may go unnoticed and the necessary instructions not followed. There is a risk of personal injury.

- Keep all relevant markings and inscriptions on the device in a constantly legible state.
- Immediately renew damaged, missing or incorrect nameplates or labels.

Risk of hearing loss or deafness due to loud noise.

The noise emissions depend on the valve version, plant facilities and process medium.

- Wear hearing protection when working near the valve. Follow the instructions given by the plant operator.

Crush hazard arising from moving parts.

The regulator contains moving parts (set point springs), which can injure hands or fingers if inserted into the regulator.

- Do not insert hands or fingers between the set point springs while the regulator is in operation.
- Before performing any work on the regulator, depressurize the plant. Disconnect or shut off the control line.

Risk of personal injury due to loaded springs.

The set point springs of regulators with adjusted set point are preloaded and are under tension.

- Before starting any work on the springs, relieve the compression from the preloaded springs.

WARNING

Risk of personal injury due to pressurized components and process medium being discharged.

Incorrect opening of pressure equipment or mounting parts may lead to the process medium escaping to the atmosphere.

- Do not loosen the control line while the valve is pressurized.
- Do not start up the regulator until all parts have been mounted.

Risk of burn injuries due to hot or cold components and pipelines.

Depending on the process medium, regulator components and pipelines may get very hot or cold and cause burn injuries.

- Allow components and pipelines to cool down or warm up to the ambient temperature.
- Wear protective clothing and safety gloves.

Damage to health relating to the REACH regulation.

If a SAMSON device contains a substance listed as a substance of very high concern on the candidate list of the REACH regulation, this is indicated on the SAMSON delivery note.

- Information on safe use of the part affected ► www.samsongroup.com/en/about-samson/material-compliance/reach-regulation/.

Risk of personal injury due to residual process medium in the regulator.

While working on the regulator, residual process medium can escape and, depending on its properties, may lead to personal injury, e.g. (chemical) burns.

- If possible, drain the process medium from all the plant sections affected and the regulator.
- Wear protective clothing, safety gloves and eye protection.

1.3 Notes on possible property damage

! NOTICE

Risk of regulator damage due to incorrectly attached slings.

- Do not attach load-bearing slings to the actuator housing (see information under 'Lifting the regulator' in the 'Shipment and on-site transport' section).

Risk of regulator damage due to unsuitable medium properties.

The regulator is designed for a process medium with defined properties.

- Only use the process medium specified for sizing the equipment.

Risk of regulator damage due to contamination (e.g. solid particles) in the pipeline.

The plant operator is responsible for cleaning the pipelines in the plant.

- Flush the pipelines before start-up.

Risk of regulator damage due to the use of unsuitable lubricants.

The lubricants to be used depend on the regulator material. Unsuitable lubricants may corrode and damage surfaces.

- Only use lubricants approved by SAMSON.
When in doubt, consult SAMSON.

Risk of leakage and regulator damage due to excessively high or low tightening torques.

Observe the specified torques when tightening regulator components. Excessive tightening torques lead to parts wearing out more quickly. Parts that are too loose may cause leakage.

- Observe the specified tightening torques (see 'Tightening torques' in Annex).

Risk of regulator damage due to the use of unsuitable tools.

Certain tools are required to work on the regulator.

- Only use tools approved by SAMSON.
When in doubt, consult SAMSON.

! NOTICE

Risk of the process medium being contaminated through the use of unsuitable lubricants and/or contaminated tools and components.

- Keep the regulator and the tools used free from solvents and grease.
- Make sure that only suitable lubricants are used.

Risk of excess pressure damaging plant sections due to construction-related seat leakage through the regulator.

- Always install a safety device (e.g. safety excess pressure valve or safety relief valve) in the plant.

Incorrect control due to the formation of ice on the regulator.

Medium temperatures below 0 °C may cause ice to form on the regulator, depending on the air humidity. This may affect, in particular, the functioning of the plug or diaphragm stem guide.

- Prevent the formation of ice by taking appropriate precautions (e.g. enclosure, trace heater etc.). The plant operator is responsible for selecting and implementing appropriate precautions. See the 'Installation' section.

i Note

SAMSON's After-sales Service can support you concerning lubricant, tightening torques and tools approved by SAMSON.

2 Markings on the device

Several nameplates are affixed to the device. The nameplates shown were up to date at the time of publication of this document. The nameplates on the device may differ from

the ones shown. The nameplates are used to identify the separate regulator components (see section 2.1).

2.1 Nameplates

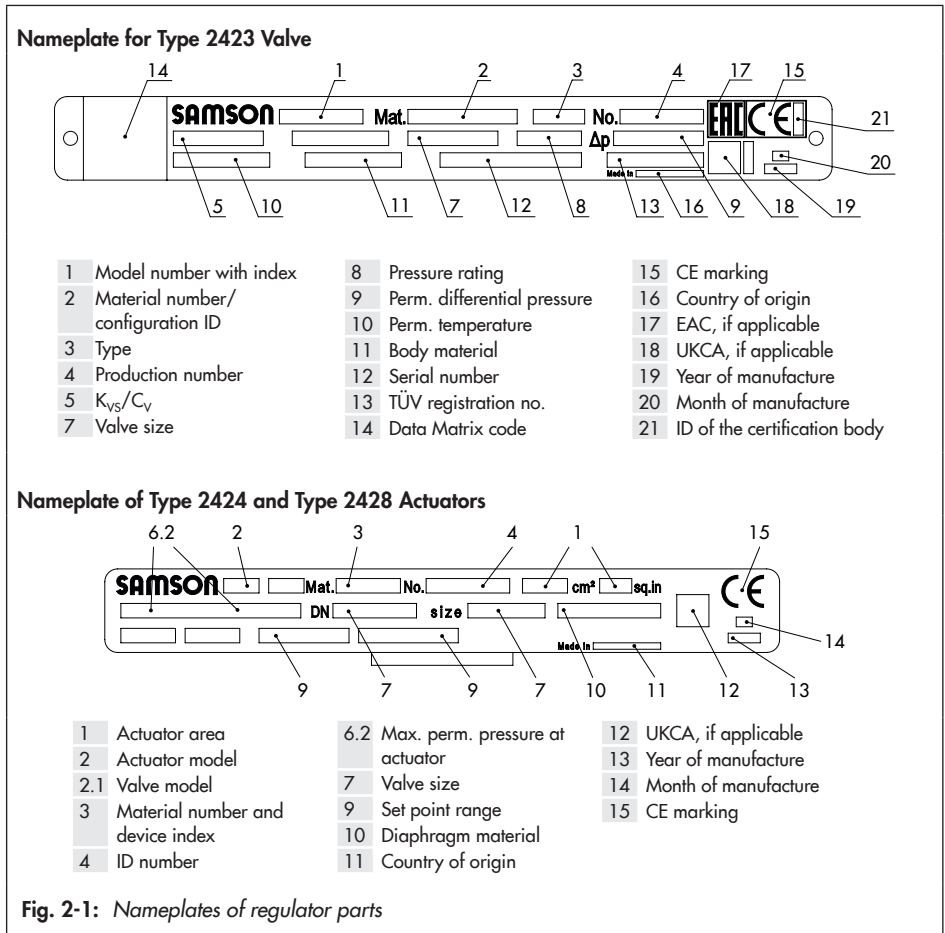

Fig. 2-1: Nameplates of regulator parts

2.2 Location of the nameplates

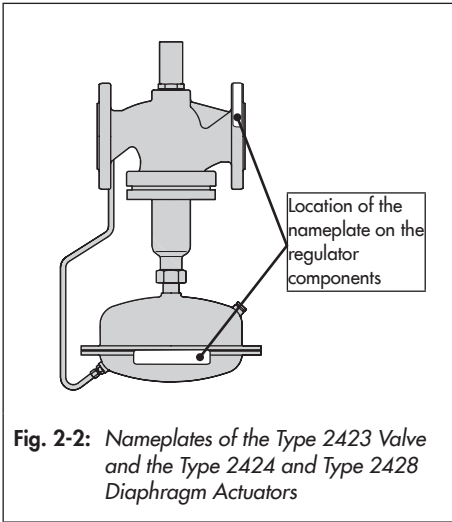

Fig. 2-2: Nameplates of the Type 2423 Valve and the Type 2424 and Type 2428 Diaphragm Actuators

2.3 Material identification number

2.3.1 Type 2423 Valve

See the nameplate (11 for DIN/ANSI version, body material) for the material used. For more details on the nameplate, see section 2.1.

2.3.2 Type 2424 and Type 2428 Actuators

Specifying the material number, you can contact us to find out which material is used. It is specified on the nameplate in the 'MNo.' field (3 for DIN/ANSI). For more details on the nameplate, see section 2.1.

3 Design and principle of operation

→ See Fig. 3-1 and Fig. 3-2

The differential pressure regulators with flow limitation are designed to maintain the differential pressure between the high-pressure and low-pressure lines to a defined set point. The flow rate can be limited by the restriction integrated in the valve body.

Type 42-34 · The set point can be adjusted as required within the set point range.

Type 42-38 · The set point is fixed.

The regulators basically consist of the Type 2423 Valve with seat (2), plug (3) and restriction (1.4) as well as a closing actuator (Type 2424 or Type 2428) with an operating diaphragm (13).

Valve and actuator are delivered separately and must be assembled on site using a coupling nut (11).

The medium flows through the valve in the direction indicated by the arrow. The areas released by the restriction (1.4) and the valve plug (3) determine the flow rate and the differential pressure Δp_{plant} across the plant. See 'Pressure conditions in the plant and at the regulator' in the 'Operation' section.

In fully balanced valves, the forces acting on the valve plug created by the upstream and downstream pressures are balanced by a balancing bellows (5) or balancing diaphragm (5.1). Regulators balanced by a bellows or a diaphragm only differ in the pressure balancing principle applied. Valves balanced by a diaphragm (DN 65 to 250 only)

have a balancing diaphragm (5.1) instead of the balancing bellows (5). The downstream pressure p_2 acts on the bottom of the diaphragm and the upstream pressure p_1 on the top of the diaphragm. As a result, the forces created by the upstream and downstream pressures acting on the plug are balanced out.

The regulators in DN 15 to 100 are fitted with a connecting piece (10) for the low-pressure control line between the valve and actuator.

To control the differential pressure, the high pressure (flow) of the plant is transmitted over the high-pressure control line to the bottom diaphragm chamber of the actuator. The pressure downstream of the restriction (1.4) is transmitted through the hollow plug stem and the attached low-pressure control line to the top diaphragm chamber of the actuator. The differential pressure is converted into a set point force at the operating diaphragm (13) and used to move the plug according to the force of the set point springs (16). Depending on the actuator version, the set point springs installed in the actuator (Type 42-38) define the set point or the springs are mounted externally to allow the set point to be adjusted (Type 42-34).

The flow set point screw (1.1) with the adjusted restriction (1.4) is used to change the cross-sectional area of flow to adjust the maximum flow rate.

The force limiter (20) and internal excess pressure limiter (21) protect the seat and plug from overload during exceptional operating conditions.

Design and principle of operation

Type 2423 Valve, DN 15 to 250 · Balanced by a bellows

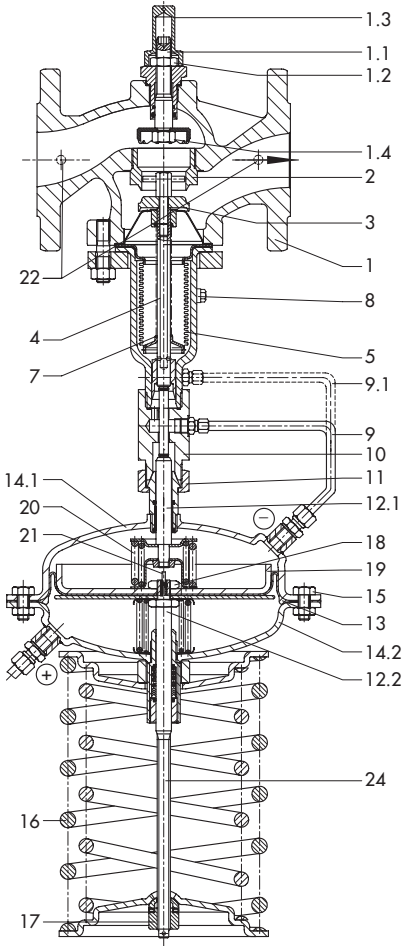

Type 2424 Actuator
Type 42-34

Type 2423 Valve
DN 15 to 100 · Balanced by a bellows

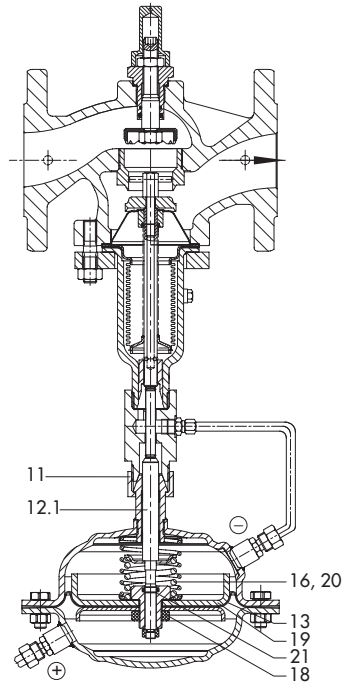

Type 2428 Actuator
Type 42-38

Fig. 3-1: Functional diagram for regulators, DN 15 to 250 with balancing bellows

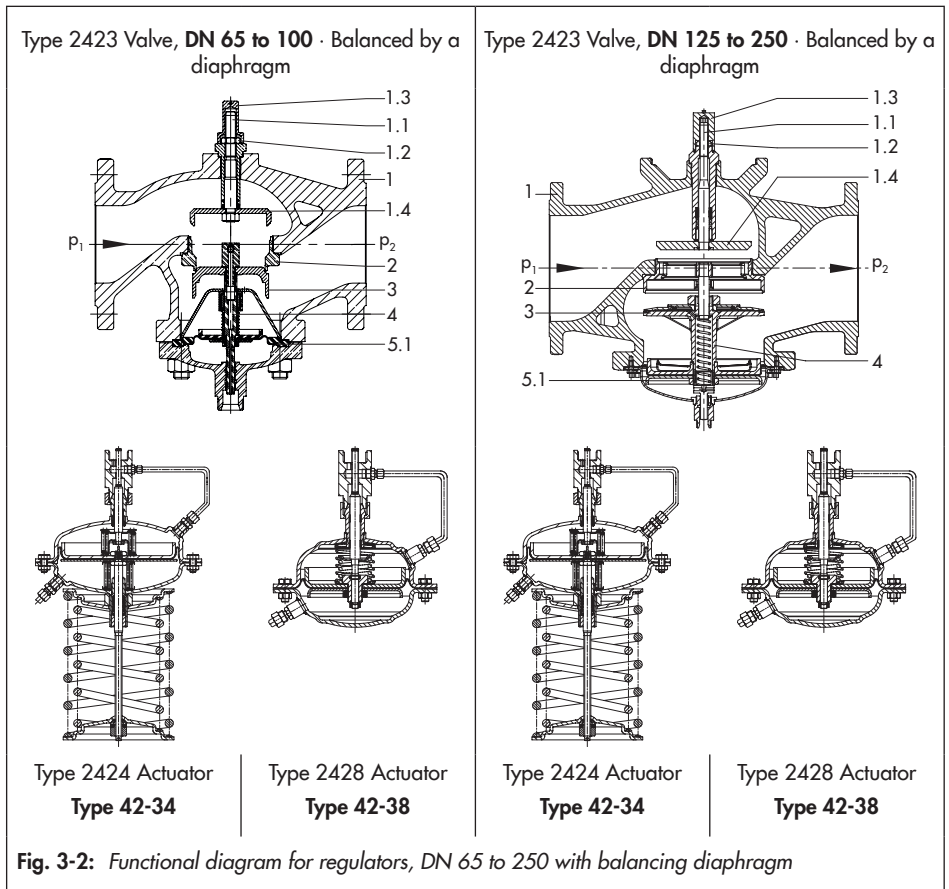

Fig. 3-2: Functional diagram for regulators, DN 65 to 250 with balancing diaphragm

Legend for Fig. 3-1 and Fig. 3-2

1 Valve body	5.1 Balancing diaphragm	11 Coupling nut	17 Set point adjustment for differential pressure (set point adjuster)	
Flow set point adjustment (set point screw)	7 Spring	12.1 Diaphragm stem		
1.1 adjustment	8 Screw plug (balanced by a bellows, DN 125 and larger)	12.2 Diaphragm stem		
1.2 Lock nut	9 Low-pressure control line (up to DN 100)	13 Operating diaphragm		
1.3 Cap	9.1 Low-pressure connection (DN 125 and larger)	14.1 Top diaphragm case (valve on top)		
1.4 Restriction	10 Connecting piece (up to DN 100)	14.2 Bottom diaphragm case (valve on top)		
2 Seat		15 Nuts and bolts		
3 Plug		16 Set point springs		
4 Plug stem				
5 Balancing bellows				
				18 Nut
				19 Diaphragm plate
				20 Force limiter
				21 Internal excess pressure valve
				22 Blanking plug at side
				24 Diaphragm stem

3.1 Additional fittings

→ See Fig. 3-3

Pressure gauges

Install a pressure gauge (3 and 5) at suitable points to monitor the pressures prevailing in the plant.

Bypass and shut-off valves

We recommend installing a shut-off valve (1, 6) both upstream of the strainer and downstream of the regulator and installing a bypass line (18). The bypass ensures that the plant does not need to be shut down for service and repair work on the regulator.

Strainers

We recommend installing a SAMSON strainer (2) upstream of the valve. It prevents solid particles in the process medium from damaging the regulator.

- Do not use the strainer to permanently filter the process medium.
- Select a strainer (mesh size) suitable for the process medium.

i Note

Any impurities carried along by the process medium may impair the proper functioning of the regulator. We recommend installing a strainer (e.g. SAMSON Type 2 NI) upstream of the pressure reducing valve (► EB 1015).

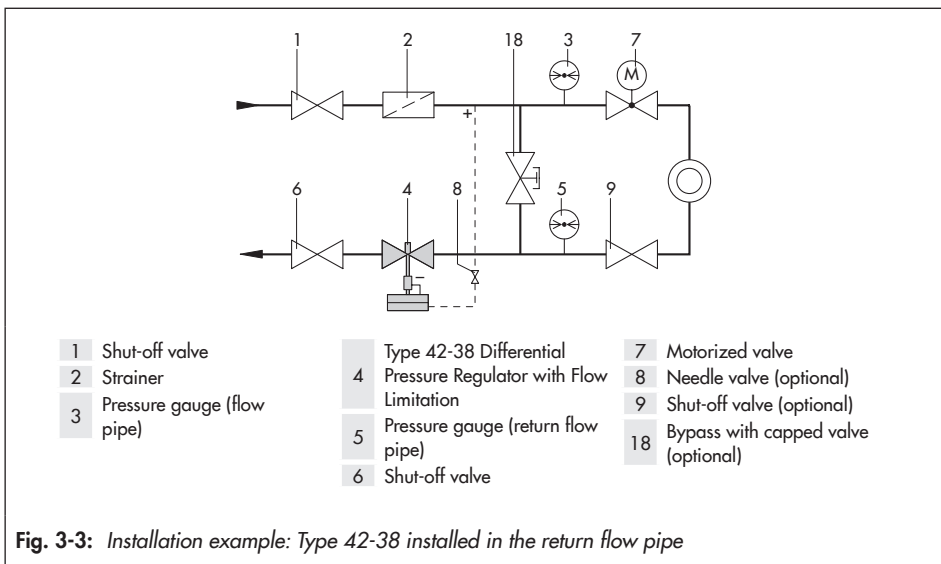

Insulation

Regulators can be insulated to reduce heat energy transfer.

Refer to the instructions in the 'Installation' section.

i Note

The Type 42-34 and Type 42-38 Regulators are not safety valves. If necessary, a suitable overpressure protection must be installed on site in the plant section.

3.1.1 Versions

Type 42-34 and Type 42-38 Differential Pressure Regulators with Flow Limitation are designed for installation in the return flow pipe, e.g. a district heating station with indirect connection.

- **Type 42-34** · With adjustable differential pressure and flow limitation · With internal overload protection (excess pressure limiter) in the actuator
- **Type 42-38** · With fixed differential pressure and adjustable flow limitation · With internal overload protection (excess pressure limiter) in the actuator

Regulator configurations

The regulators consist of a valve and an actuator with adjustable restriction. They control the differential pressure to the set point adjusted at the actuator and limit the flow rate to the value adjusted at the restriction.

Type 42-34 with connecting piece (DN 15 to 100)	
Consisting of:	
Valve	- Type 2423, balanced
Actuator	- Type 2424 adjustable set point
Type 42-38 with connecting piece	
Consisting of:	
Valve	- Type 2423, balanced
Actuator	- Type 2428 fixed set point

3.2 Technical data

The valve and actuator nameplates provide information on the valve and actuator versions (see the 'Markings on the device' section).

i Note

More information is available in Data Sheet T 3013.

Conformity

The Type 42-34 and Type 42-38 Regulators bear the CE, UKCA and EAC marks of conformity.

CE

UK
CA

EAC

Process medium and scope of application

The differential pressure regulators with flow limitation are designed to maintain the differential pressure between the high-pressure and low-pressure lines to a defined set point and to limit the flow rate.

- Suitable for **liquids** from **5 to 150 °C**
- Max. temperature **150 °C**
- Differential pressure set points **from 0.1 to 2.5 bar**
- Adjustable flow rate range from **0.05 to 520 m³/h**
- Valve size **DN 15 to 250**
- Pressure ratings from **PN 16 to 40**

The regulator is open when relieved of pressure. The valve **closes** when the differential pressure or flow rate **rises**.

i Note

The materials used in the regulator are also resistant to high concentrations of glycol. Nevertheless, glycol reacts when it comes in contact with metals and causes acids to form. We cannot prevent this reaction. Therefore, prevent it through the use of suitable inhibitors.

Leakage class

The metal-seated regulator has the leakage class I according to IEC 60534-4. The soft-seated regulator has the leakage class IV according to IEC 60534-4.

Temperature range

Depending on how the regulator is configured, it can be used up to temperatures of 150 °C/300 °F (see Table 3-1). The minimum temperature is limited by the accessories used and the actuator's diaphragm material (► T 3013).

Noise emissions

SAMSON is unable to make general statements about noise emissions. The noise emissions depend on the regulator version, plant facilities, process medium and operating conditions.

Dimensions and weights

Table 3-6 to Table 3-7 provide an overview of the dimensions and weights. The lengths and heights in the dimensional drawings are shown on pages 3-10 and 3-11.

Table 3-1: Technical data · All pressures in bar (gauge)

Type	42-34		42-38
Balancing	Balanced by a diaphragm	Balanced by a bellows	Balanced by a bellows
Valve size	DN 65 to 250	DN 15 to 250	DN 15 to 100
Pressure rating	PN 16, 25, 40		
Pressure at which internal excess pressure limiter responds	A = 160 cm ²	1.2 bar	0.6 bar
	A = 320 cm ²	0.6 bar	0.3 bar
	A = 640 cm ²	0.3 bar	–
Max. permissible temperature	Valve	150 °C	See pressure-temperature diagram in ► T 3000
	Actuator ¹⁾	Liquids up to 150 °C	
Set point ranges	0.1 to 0.6 bar · 0.2 to 1 bar 0.5 to 1.5 bar · 1 to 2.5 bar		0.2 to 0.5 bar (in 0.1 bar increments)
Max. permissible operating pressure	40 bar for 160 to 320 cm ² · 40 and 16 bar for 640 cm ²		
Max. perm. operating pressure for actuator with two diaphragms	40 bar for 160 cm ² 25 bar for 320 and 640 cm ²		–
Conformity	CE · UK · ENEC		
Leakage class according to IEC 60534-4	≤0.05 % of K _{VS} coefficient		

¹⁾ Higher temperatures on request

Table 3-2: K_{VS} coefficients, x_{FZ} values and max. permissible differential pressures Δp

Type 2423 Valve · Balanced by a bellows														
Valve size DN	15	20	25	32	40	50	65	80	100	125	150	200	250	
Valve travel	10 mm						16 mm			22 mm				
K _{VS} coefficient	4.0	6.3	8.0	16	20	32	50	80	125	190	280	420	500	
Max. perm. diff. pressure Δp	25 bar						20 bar		16 bar		12 bar		10 bar	
x _{FZ} value	0.65	0.6	0.55	0.45	0.4		0.35				0.3			
Type 2423 Valve · Balanced by a diaphragm														
Valve size DN	65	80	100	125	150	200	250							
Valve travel	15 mm						35 mm							
K _{VS} coefficient	50	80	125	250	390	650	800							
Max. perm. diff. pressure Δp	10 bar						12 bar			10 bar				
x _{FZ} value	0.4	0.35						0.3						

Design and principle of operation

Table 3-3: Materials · Material numbers according to DIN EN

Type 2423 Valve			
Pressure rating	PN 16	PN 16, 25	PN 16, 25, 40
Valve body	Cast iron EN-GJL-250	Spheroidal graphite iron EN-GJS-400-18-LT	Cast steel 1.0619
Type 2423 Valve · Balanced by a bellows			
Seat	1.4404, 1.4006		
Plug	Up to DN 100	1.4404 or 1.4006 ¹⁾	
	DN 125 to 250	1.4301, 1.4404 with PTFE soft seal	
Plug stem	1.4301		
Metal bellows	DN 15 to 100: 1.4571 · DN 125 to 250: 1.4404		
Bottom section	P265GH		
Body gasket	Graphite on metal core		
Type 2423 Valve · Balanced by a diaphragm			
Seat	CC499K ²⁾	-	
Plug	CC499K ²⁾ · With EPDM or PTFE soft seal, max. 150 °C		
Pressure balancing	Balancing cases made of sheet steel DD11 · Diaphragm plate EN-JS1030 · EPDM balancing diaphragm, max. 150 °C		
Type 2424 and Type 2428 Actuators			
Diaphragm cases	1.0332	1.4301	
Diaphragm	EPDM with fabric reinforcement		
Guide bushing	DU bushing	PTFE	
Seals	EPDM/PTFE		

¹⁾ Optionally with soft seal with standard K_{VS} coefficients

²⁾ Special version in 1.4409

Table 3-4: Flow rate set point ranges for water · Type 2423 Valve, balanced by a bellows

$\Delta p_{\text{set point}}$	Δp_{plant}	$\Delta p_{\text{restriction}}$	DN	15	20	25	32	40	50	65	80	100	125	150	200	250
0.2 bar	0.1 bar	0.1 bar	\dot{V} Max.	1.4	2.1	2.4	4.9	7.7	11.2	19	28	44	56	84	126	154
0.5 bar	0.3 bar	0.2 bar	\dot{V} Max.	2	3	3.5	7	11	16	28	40	63	80	120	180	220
1.0 bar	0.5 bar	0.5 bar	\dot{V} Max.	3	4.5	5.3	9.5	16	24	40	58	90	120	180	260	300
Max. perm. diff. pressure Δp				25 bar						20 bar		16 bar		12 bar		10 bar

Table 3-5: Flow rate set point ranges for water · Type 2423 Valve, balanced by a diaphragm

Valve size	DN	65	80	100	125	150	200	250
Diff. pressure across restriction	0.2 bar	2 to 28	3.5 to 35 ¹⁾	6.5 to 63	11 to 120	18 to 180	20 to 320	26 to 350
$\Delta p_{\text{restriction}}$	0.5 bar	3.5 to 40	6.5 to 55	11 to 90	18 to 180	20 to 260	26 to 450	30 to 520
Max. perm. diff. pressure Δp		10 bar			12 bar		10 bar	

¹⁾ 7 to 35 m³/h (160 cm² actuator), 7 to 40 m³/h (320 cm² actuator)

Table 3-6: Dimensions and weights for Type 42-34 and Type 42-38 · Balanced by a bellows
Dimensions in mm · Weights in kg (without process medium)

Valve size	DN	15	20	25	32	40	50	65	80	100	125	150	200	250		
Length L		130	150	160	180	200	230	290	310	350	400	480	600	730		
Height H1		285						360	415	460	590	730				
Height H2		115			135			195	220	265	295	400				
Type 42-38 Differential Pressure Regulator with Flow Limitation																
Set points		Type 2428 Actuator														
0.2 bar	Height H ³⁾	450						525	585	-						
0.3 bar	Actuator	$\varnothing D = 225 \text{ mm}, A = 160 \text{ cm}^2$ ¹⁾						$\varnothing D = 285 \text{ mm} \cdot A = 320 \text{ cm}^2$								
0.4 bar																
0.5 bar	Weight ²⁾ in kg	11.5	12	13	19.5	20	22.5	45	50							58
Type 42-34 Differential Pressure Regulator with Flow Limitation																
Set points		Type 2424 Actuator														
0.1 to 0.6 bar	Height H ³⁾	670						745	800	990	1120	1260				
	Actuator	$\varnothing D = 225 \text{ mm}, A = 160 \text{ cm}^2$ ¹⁾						$\varnothing D = 285 \text{ mm}, A = 320 \text{ cm}^2$			$\varnothing D = 390 \text{ mm}, A = 640 \text{ cm}^2$					
	Weight ²⁾ in kg													16	16.5	17.5
0.2 to 1 bar	Height H ³⁾	670						745	800	990	1120	1260				
	Actuator	$\varnothing D = 225 \text{ mm}, A = 160 \text{ cm}^2$ ¹⁾						$\varnothing D = 390 \text{ mm}, A = 640 \text{ cm}^2$								
	Weight ²⁾ in kg										16	16.5	17.5	24	24.5	27
0.5 to 1.5 bar	Height H ³⁾	610						685	740	990	1120	1260				
	Actuator	$\varnothing D = 225 \text{ mm}, A = 160 \text{ cm}^2$ ¹⁾						$\varnothing D = 285 \text{ mm}, A = 320 \text{ cm}^2$								
	Weight ²⁾ in kg										16	16.5	17.5	24	24.5	27
1 to 2.5 bar	Height H ³⁾	610						685	740	990	1120	1260				
	Actuator	$\varnothing D = 225 \text{ mm}, A = 160 \text{ cm}^2$ ¹⁾														
	Weight ²⁾ in kg	16	16.5	17.5	24	24.5	27	42	47	55	125	175	425	475		

¹⁾ Optionally with 320 cm² actuator

²⁾ The weight applies to the version with the material specifications EN-GJL-250. Add +10 % for all other materials.

³⁾ Minimum clearance required to remove the actuator: +100 mm

Design and principle of operation

Table 3-7: Dimensions and weights for Type 42-34 and Type 42-38 · Balanced by a diaphragm
Dimensions in mm · Weights in kg (without process medium)

Valve size DN	65	80	100	125	150	200	250
Length L	290	310	350	400	480	600	730
Height H1	250		270	285	310	380	
Height H2	195		220	290	325	335	380
Type 42-38 Differential Pressure Regulator with Flow Limitation							
Set points		Type 2428 Actuator					
0.2 bar	Height H ⁴⁾	415		440	-		
0.3 bar	Actuator	ØD = 285 mm · A = 320 cm ²					
0.4 bar							
0.5 bar	Weight ¹⁾ in kg	40	45	55			
Type 42-34 Differential Pressure Regulator with Flow Limitation							
Set points		Type 2424 Actuator					
0.1 to 0.6 bar	Height H ⁴⁾	635		655	780	805	1020
	Actuator	ØD = 285 mm · A = 320 cm ²			ØD = 390 mm · A = 640 cm ²		
	Weight ¹⁾ in kg	47	52	62	95	115	290
0.2 to 1 bar	Height H ⁴⁾	635		655	780	805	1020
	Actuator	ØD = 225 mm · A = 160 cm ^{2 3)}			ØD = 390 mm · A = 640 cm ²		
	Weight ¹⁾ in kg	47	52	62	95	115	290
0.5 to 1.5 bar	Height H ⁴⁾	635		655	780	805	1020
	Actuator	ØD = 225 mm · A = 160 cm ^{2 3)}			ØD = 285 mm · A = 320 cm ^{2 2)}		
	Weight ¹⁾ in kg	47	52	62	95	115	290
1 to 2.5 bar	Height H ⁴⁾	635		655	780	805	1020
	Actuator	ØD = 225 mm · A = 160 cm ^{2 3)}					
	Weight ¹⁾ in kg	47	52	62	95	115	290

¹⁾ The weight applies to the version with the material specifications EN-GJL-250. Add +10 % for all other materials.

²⁾ Optionally with 640 cm² actuator

³⁾ Optionally with 320 cm² actuator

⁴⁾ Minimum clearance required to remove the actuator: +100 mm

Table 3-8: Weights of Type 2424 and Type 2428 Actuators · Weights in kg (without process medium)

Actuator area in cm ²	640	320	160 · 80 · 40
Weight [kg]	45	23	12

Dimensional drawings

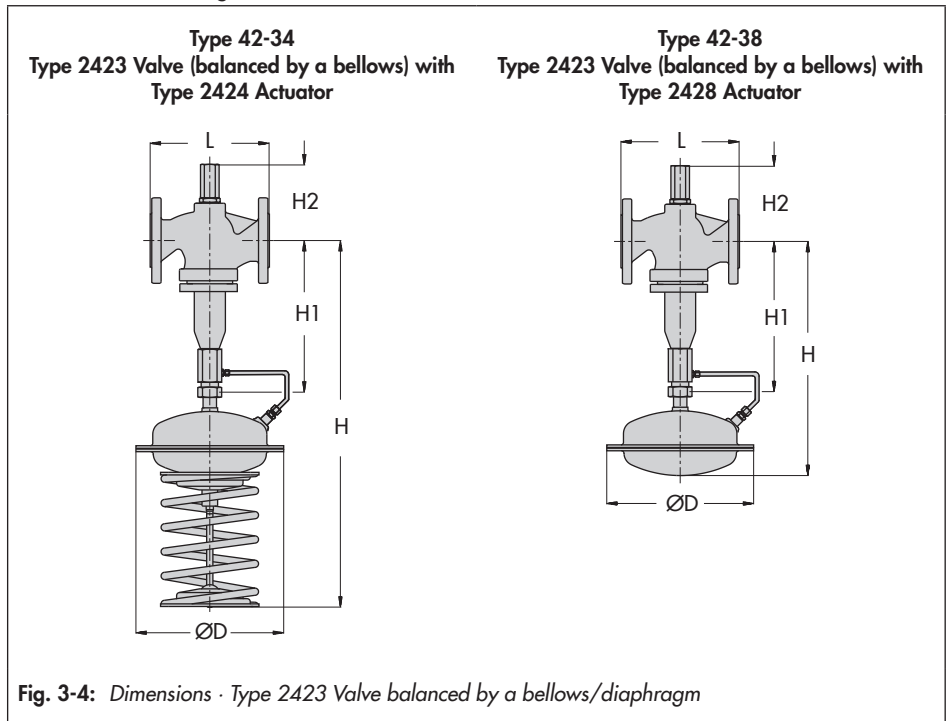

Design and principle of operation

Dimensional drawings

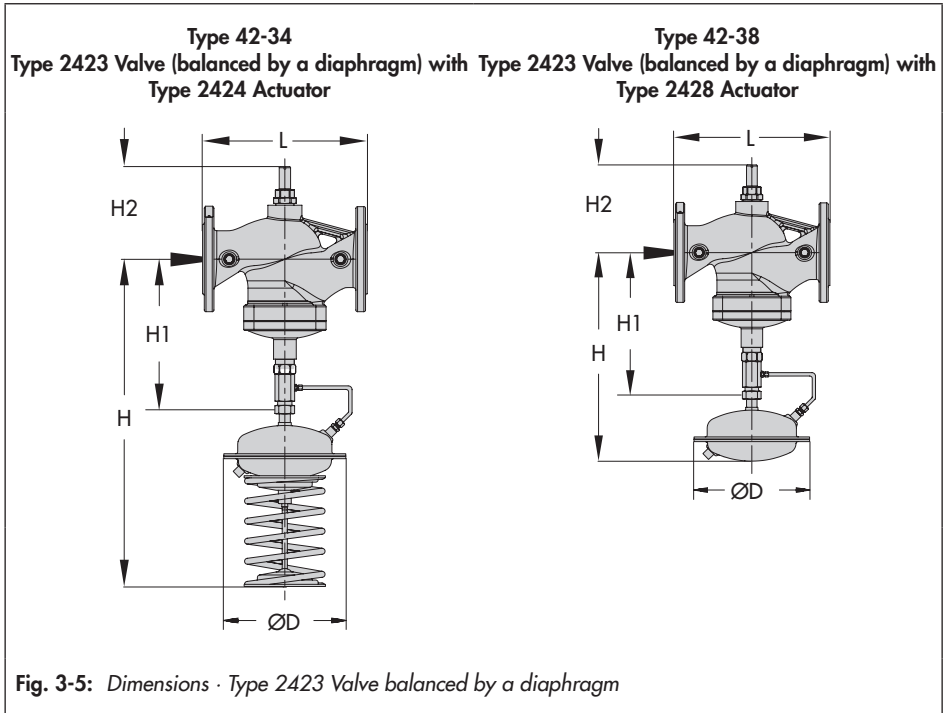

4 Shipment and on-site transport

The work described in this section is only to be performed by personnel appropriately qualified to carry out such tasks.

4.1 Accepting the delivered goods

After receiving the shipment, proceed as follows:

1. Check the scope of delivery. Check that the specifications on the valve and actuator nameplate match the specifications in the delivery note. See the 'Markings on the device' section for nameplate details.
2. Check the shipment for transportation damage. Report any damage to SAMSON and the forwarding agent (refer to delivery note).
3. Determine the weight and dimensions of the units to be lifted and transported in order to select the appropriate lifting equipment and lifting accessories. Refer to the transport documents and the 'Design and principle of operation' section.

4.2 Removing the packaging from the regulator

The components (valve, actuator and, if applicable, accessories) of the regulator are delivered separately.

Proceed as follows to lift and install the valve:

- Do not open or remove the packaging until immediately before lifting to install the regulator into the pipeline.
- Leave the regulator components in its transport container or on the pallet to transport it on site.
- Do not remove the protective caps from the inlet and outlet until immediately before installing the valve into the pipeline. They prevent foreign particles from entering the valve.
- Dispose and recycle the packaging in accordance with the local regulations.

4.3 Transporting and lifting the regulator

DANGER

Danger due to suspended loads falling.

- Stay clear of suspended or moving loads.
- Close off and secure the transport paths.

WARNING

Risk of injury due to incorrect lifting without the use of lifting equipment.

Lifting the regulator without the use of lifting equipment may lead to injuries (back injury in particular) depending on the weight of the regulator and/or actuator.

- Observe the occupational health and safety regulations valid in the country of use.
- Observe the guideline weight for manual handling: 15 to max. 55 kg per person taking into account age, gender and physical fitness.
- When the actuator is filled with medium, take the weight of the medium also into account.
- Refer to the 'Design and principle of operation' section for the weights of the regulator and actuator.

WARNING

Risk of personal injury due to the regulator tipping.

- Observe the regulator's center of gravity.

- Secure the regulator against tipping over or turning.

WARNING

Risk of lifting equipment tipping over and risk of damage to lifting accessories due to exceeding the rated lifting capacity.

- Only use approved lifting equipment and accessories whose minimum lifting capacity is higher than the weight of the valve (including actuator and packaging, if applicable).
- Refer to the 'Design and principle of operation' section for the weights.

Tip

Our after-sales service can provide more detailed transport and lifting instructions on request.

4.3.1 Transporting the regulator

The regulator can be transported using lifting equipment (e.g. crane or forklift).

- Leave the regulator in its transport container or on the pallet to transport it.
- Observe the transport instructions.

Transport instructions

- Protect the regulator against external influences (e.g. impact).
- Do not damage the corrosion protection (paint, surface coatings). Repair any damage immediately.

- Protect the regulator against moisture and dirt.
- Protect the piping and any mounted valve accessories against damage.
- The permissible ambient temperature of standard regulators is -20 to $+80$ °C.

4.3.2 Lifting the regulator

To install a large regulator into the pipeline, use lifting equipment (e.g. crane or forklift) to lift it.

Lifting instructions

- Use a hook with safety latch to secure the slings from slipping off the hook during lifting and transporting (see Fig. 4-1).
- Secure slings against slipping.
- Make sure the slings can be removed after installation.
- Prevent the regulator from tilting or tipping.
- Do not leave loads suspended when interrupting work for longer periods of time.
- Make sure that the axis of the pipeline is always horizontal during lifting and the axis of the pipe stem is always vertical.

Lifting

1. Attach one sling to the flange of the body and to the rigging equipment (e.g. hook) of the crane or forklift (see Fig. 4-1).
2. Carefully lift the regulator. Check whether the lifting equipment and accessories can bear the weight.
3. Move the regulator at an even pace to the site of installation.
4. Install the regulator into the pipeline (see the 'Installation' section).
5. After installation in the pipeline, check whether the regulator flanges are bolted tight.
6. Remove slings.

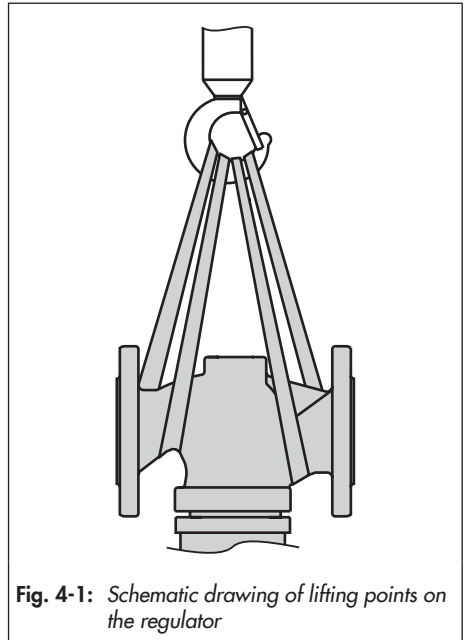

Fig. 4-1: Schematic drawing of lifting points on the regulator

4.4 Storing the regulator

NOTICE

Risk of regulator damage due to improper storage.

- Observe the storage instructions.
- Avoid long storage times.
- Contact SAMSON in case of different storage conditions or longer storage times.

Note

We recommend regularly checking the regulator and the prevailing storage conditions during long storage periods.

Storage instructions

- Protect the regulator against external influences (e.g. impact).
- Secure the regulator in the stored position against slipping or tipping over.
- Do not damage the corrosion protection (paint, surface coatings). Repair any damage immediately.
- Protect the regulator against moisture and dirt. Store it at a relative humidity of less than 75 %. In damp spaces, prevent condensation. If necessary, use a drying agent or heating.
- Make sure that the ambient air is free of acids or other corrosive media.
- The permissible storage temperature of standard regulators is -20 to +65 °C.

- Do not place any objects on the regulator.

Special storage instructions for elastomers

Elastomer, e.g. operating diaphragm

- To keep elastomers in shape and to prevent cracking, do not bend them or hang them up.
- Store elastomers away from lubricants, chemicals, solutions and fuels.
- We recommend a storage temperature of 15 °C for elastomers.

Tip

SAMSON's After-sales Service can provide more detailed storage instructions on request.

5 Installation

The work described in this section is only to be performed by personnel appropriately qualified to carry out such tasks.

5.1 Installation conditions

Work position

The work position for the regulator is the front view onto all operating controls on the regulator (including any additional fittings) seen from the position of operating personnel.

Plant operators must ensure that, after installation of the device, the operating personnel can perform all necessary work safely and easily access the device from the work position.

Pipeline routing

The inlet and outlet lengths vary depending on several variables and process conditions and are intended as recommendations. Contact SAMSON if the lengths are significantly shorter than the recommended lengths.

To ensure that the regulator functions properly, proceed as follows:

- Observe the inlet and outlet lengths (see Table 5-1). Contact SAMSON if the regulator conditions or state of the medium process deviate.
- Install the regulator free of stress and with the least amount of vibrations as possible. Read information under 'Mounting position' and 'Support or suspension' in this section.

- For media with a tendency to condensate, an automatic drainage must be installed. Install the pipeline with a slight downward slope on both sides of the regulator to prevent condensate from collecting in the valve.
- Install the regulator allowing sufficient space to remove the actuator and valve or to perform service work on them.

Mounting position

To ensure that the regulator functions properly, proceed as follows:

- Standard mounting position: install the actuator housing suspended downward in horizontal pipelines (see Fig. 5-1).
- Make sure the direction of flow matches the direction indicated by the arrow on the body.
- Contact SAMSON if the mounting position is not as specified above.

NOTICE

Damage due to freezing.

Protect the regulator from icing up when controlling media that can freeze. Unless the regulator is installed in locations where no frost occurs, remove the regulator from the pipeline when the plant is shut down.

Standard mounting position, suspended



Balanced by a bellows or diaphragm
All versions
– Air and gases up to 80 °C
– Liquids up to 150 °C

Balanced by a bellows
– All media above 80 °C

Alternative mounting position, actuator on top



Balanced by a diaphragm · DN 65 to 80
– Air and gases up to 80 °C
– Liquids up to 120 °C



Balanced by a bellows · DN 15 to 80
All versions plus:
– Air and gases up to 80 °C
– Liquids up to 120 °C

Alternative mounting position in riser pipes · Balanced by a bellows

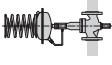

Version with fixed plug guide plus:
– Air and gases up to 80 °C
– Liquids up to 120 °C

Fig. 5-1: Mounting position

Support or suspension

i Note

The plant engineering company is responsible for selecting and implementing a suitable support or suspension of the installed regulator and the pipeline.

! NOTICE

Risk of regulator damage due to incorrect support.

- Do not attach supports to the valve, to moving parts on the actuator or to the control lines.
- Contact SAMSON if the mounting position differs from the standard mounting position.

Depending on the regulator version and mounting position, the valve, actuator and pipeline must be supported or suspended.

Control line

Route the control lines on site preferably using a 8x1 mm (stainless) steel pipe. The pressure tapping point must at least three times the valve size (DN) away from any pipe fittings (e.g. restrictions, bends or branches), that may cause turbulence in the flow. How the lines are routed generally depends on the installation site.

- Preferably connect the control line to the side of the main pipe (see Fig. 5-2 and Table 5-1).
- Do not change the pipe diameter of the main pipeline with an eccentric reducer.

💡 Tip

Control line kits, needle valves, condensation chambers and compression-type screw fittings can be supplied as required. These accessories are listed in ► T 3095.

Needle valve

To additionally dampen the regulator or to shut off the control lines, we recommend also installing a needle valve in the control line in addition to the standard SAMSON screw joint with restriction. The standard SAMSON screw joint with restriction is located in the compression-type fitting at the (+) connection of the diaphragm actuator.

Proceed as follows:

- ➔ Lay out the necessary material and tools to have them ready during installation work.
- ➔ Check any mounted pressure gauges to make sure they function properly.

5.2 Preparation for installation

Valve and actuator can be assembled before or after the valve has been installed in the pipeline. We recommend first installing the valve without the actuator into the pipeline.

Before installation, make sure the following conditions are met:

- The valve is clean.
- The valve, actuator and all piping are not damaged.
- Install a strainer upstream of the regulator.
- The valve data on the nameplate (type designation, valve size, material, pressure rating and temperature range) match the plant conditions (size and pressure rating of the pipeline, medium temperature etc.). See the 'Markings on the device' section for nameplate details.
- The requested or required additional fittings (see the 'Design and principle of operation' section) have been installed or prepared as necessary before installing the valve.

Table 5-1: Inlet and outlet lengths (valve) and control line connections

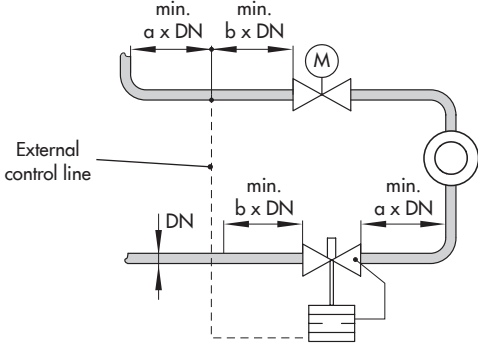

Control line connection, depending on how the pipeline is routed and depending on the components

a Inlet length
b Outlet length

State of process medium	Valve conditions	Inlet length a	Outlet length b
Liquid	Free of cavitation/ $w < 3 \text{ m/s}$	2	4
	Cavitation producing noise/ $w \leq 3 \text{ m/s}$	2	4

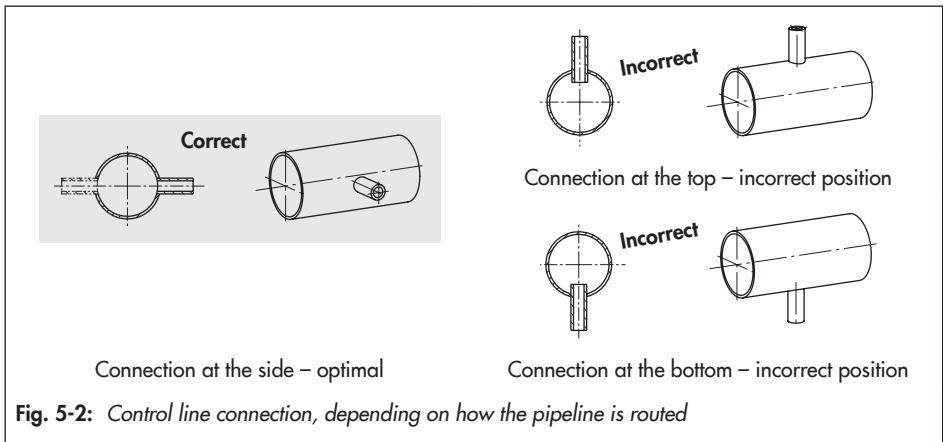

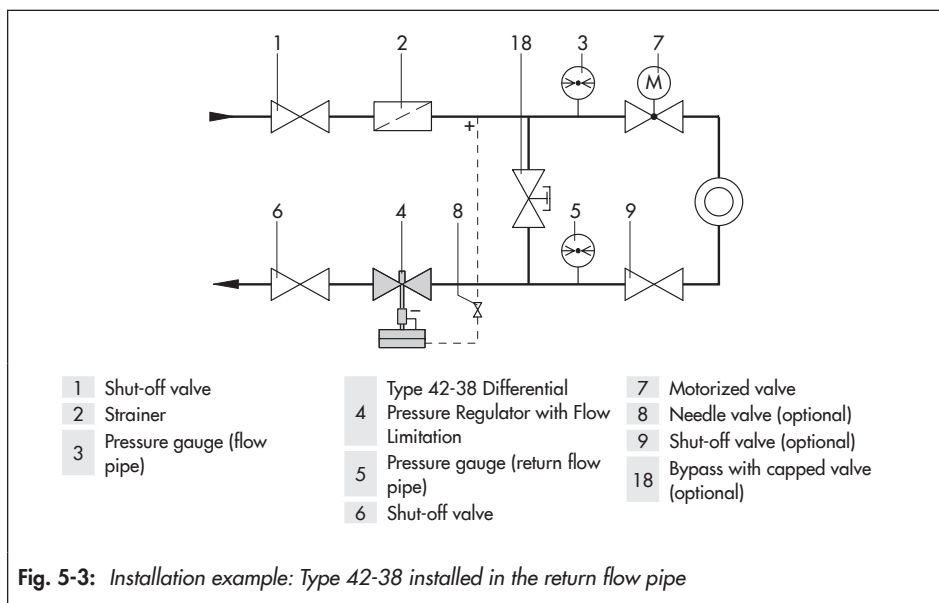

5.3 Installation

The components (valve, actuator and, if applicable, accessories) of the SAMSON regulator are delivered separately. Upon delivery, the separate components must be assembled together. The activities listed below are necessary for installation and before start-up of the regulator.

⚠ DANGER

Danger due to suspended loads falling.

- Stay clear of suspended or moving loads.
- Close off and secure the transport paths.

⚠ WARNING

Risk of lifting equipment tipping over and risk of damage to lifting accessories due to exceeding the rated lifting capacity.

- Only use approved lifting equipment and accessories whose minimum lifting capacity is higher than the weight of the valve (including actuator and packaging, if applicable).
- Refer to the 'Design and principle of operation' section for the weights.

⚠ WARNING

Risk of personal injury due to the regulator tipping.

- Observe the regulator's center of gravity.
- Secure the regulator against tipping over or turning.

⚠ WARNING

Risk of injury due to incorrect lifting without the use of lifting equipment.

Lifting the regulator without the use of lifting equipment may lead to injuries (back injury in particular) depending on the weight of the regulator and/or actuator.

- Observe the guideline weight for manual handling: 15 to max. 55 kg per person taking into account age, gender and physical fitness.
- When the actuator is filled with medium, take the weight of the medium also into account.
- Refer to the 'Design and principle of operation' section for the weights of the regulator and actuator.
- Observe the occupational health and safety regulations valid in the country of use.

ⓘ NOTICE

Risk of regulator damage due to the use of unsuitable tools.

- Only use tools approved by SAMSON (see 'Tools' in Annex).

ⓘ NOTICE

Risk of regulator damage due to the use of unsuitable lubricants.

- Only use lubricants approved by SAMSON (see 'Lubricants' in Annex).

NOTICE**Risk of regulator damage due to excessively high or low tightening torques.**

Observe the specified torques when tightening regulator components. Excessive tightening torques lead to parts wearing out more quickly. Parts that are too loose may cause leakage.

→ Observe the specified tightening torques (see 'Tightening torques' in Annex).

5.3.1 Installing the regulator

The regulator is installed in the downstream pressure pipe (return flow pipe) of the plant. See installation examples in Fig. 5-3.

1. Close the shut-off valves (1, 6) upstream and downstream of the regulator while the regulator is being installed.
2. Remove the protective caps from the valve ports before installing the valve.
3. Lift the valve using suitable lifting equipment to the site of installation. Observe the flow direction through the valve. The arrow on the valve indicates the direction of flow.
4. Make sure that the correct flange gaskets are used.
5. Bolt the pipe to the valve free of stress.
6. Mount the actuator.
 - Fasten the actuator on the valve by tightening the coupling nut (11), while observing the alignment of the control line connections. Observe the specified tight-

ening torques (see 'Tightening torques' in Annex).

7. Mount the control lines (to be installed on site) and any needle valves and open them.
 - Mount the control lines (to be installed on site) on the actuator. Observe the specified tightening torques (see 'Tightening torques' in Annex).

5.4 Testing the regulator

⚠ DANGER**Risk of bursting due to incorrect opening of pressurized equipment or components.**

Regulators and pipelines are pressure equipment that may burst when handled incorrectly. Flying projectile fragments or the release of process medium under pressure can cause serious injury or even death.

Before working on the regulator:

- Depressurize all plant sections concerned and the regulator.
- Disconnect the control line.
- Drain the process medium from all the plant sections concerned as well as the valve.

WARNING

Risk of personal injury due to pressurized components and process medium being discharged.

Incorrect opening of pressure equipment or mounting parts may lead to the process medium escaping to the atmosphere.

- ➔ *Do not loosen the control line while the valve is pressurized.*
- ➔ *Do not start up the regulator until all parts have been mounted.*

WARNING

Risk of hearing loss or deafness due to loud noise.

Noise emission (e.g. cavitation) may occur during operation caused by the process medium and the operating conditions.

- ➔ *Wear hearing protection when working near the valve. Follow the instructions given by the plant operator.*

WARNING

Risk of burn injuries due to hot or very cold components and pipelines.

Depending on the process medium, valve components and pipelines may get very hot or cold and cause burn injuries.

- ➔ *Wear protective clothing and safety gloves.*

The regulator components are delivered by SAMSON ready for use. To test the regulator functioning before start-up or putting back the regulator into operation, perform the following tests:

5.4.1 Leak test

The plant operator is responsible for performing the leak test and selecting the test method. The leak test must comply with the requirements of the national and international standards that apply at the site of installation.

Tip

SAMSON's After-sales Service can support you to plan and perform a leak test for your plant.

- ➔ All required control lines are connected to the actuator and are not shut off.
- 1. Install the regulator into the pipeline. See section 'Installation'.
- 2. Apply the required test pressure.
- 3. Check the regulator for leakage to the atmosphere.
- 4. Depressurize the pipeline section and regulator.
- 5. Rework any parts that leak and repeat the leak test.

5.4.2 Pressure test

NOTICE

Risk of valve damage due to a sudden pressure increase.

– Slowly open the shut-off valves.

Note

The plant operator is responsible for performing the pressure test. SAMSON's After-sales Service can support you to plan and perform a pressure test for your plant.

Pressure test with mounted diaphragm actuator

During the pressure test, make sure the following conditions are met:

- All required control lines are connected to the actuator and are not shut off.
- Do not allow the pressure to exceed the 1.5 times the pressure rating of the valve body.
- Do not apply a pressure higher than the maximum specified pressure rating or maximum operating pressure to the actuator (see 'Technical data' in the 'Design and principle of operation' section).
- Make sure that the pressure rises simultaneously upstream and downstream of the regulator to avoid damaging the balancing bellows or the balancing diaphragm.

If the **test pressure** of the valve is **higher** than the specified maximum permissible operating pressure of the diaphragm actuator:

- Depressurize the plant.
- Remove the control line (9 or 9.1) and seal the connection at the valve with a blanking plug.
- Remove the control line mounted on site. Close any control line connection in the plant by closing the installed shut-off valve or inserting a blanking plug.
- Seal the body connections with blanking plugs.

The diaphragm actuator remains mounted on the valve and seals off the valve.

Pressure test without mounted diaphragm actuator

WARNING

Risk of personal injury due to pressurized components and process medium being discharged.

Incorrect opening of pressure equipment or mounting parts may lead to the process medium escaping to the atmosphere.

- Do not loosen the control line while the valve is pressurized.
- Do not start up the regulator until all parts have been mounted.

If the valve is not sealed off, the test medium escapes at the connection where the actuator is connected to the valve. It is not possible to perform a pressure test on the valve in this case (see Fig. 5-4).

- Seal off the valve using a coupling nut (0250-1037) with seal (0340-1962).

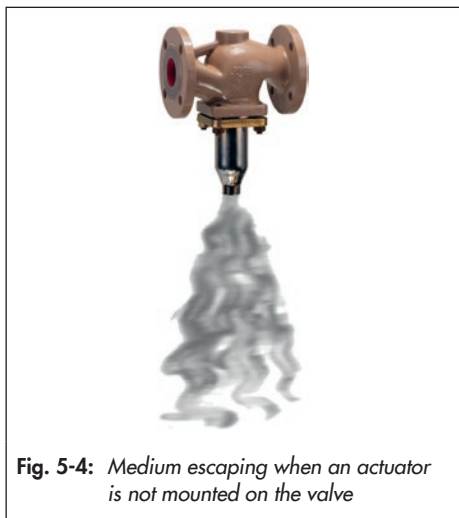

Fig. 5-4: *Medium escaping when an actuator is not mounted on the valve*

- Before flushing the plant with the process medium, read the information under 'Starting up the plant' in the 'Start-up' section.
- A higher set point is adjusted at the controller and all consumers are open to guarantee a high flow rate.
- Observe the mesh size of the upstream strainer for the maximum particle size. Use strainers to suit the process medium.
- Check the strainer for dirt each time the pipeline is flushed and clean it, if necessary.

If the regulator malfunctions due to clogging after flushing the pipeline, proceed as described in the 'Troubleshooting' section.

5.4.3 Filling the plant

Open the shut-off valves slowly over a time period of several minutes preferably starting from the upstream pressure side to fill the plant (all consumers and control lines are open).

- Make sure that the pressure rises simultaneously upstream and downstream of the regulator to avoid damaging the balancing bellows or the balancing diaphragm.

5.4.4 Cleaning the pipeline

We recommend additionally flushing the pipeline with installed regulator over a time period of several minutes before start-up.

- All required control lines are connected and not shut off.

5.5 Insulation

To insulate cold systems, we recommend first filling the plant and carefully rinsing it. The regulator must not yet be insulated at this stage.

1. Start up the plant and adjust the set point (see the 'Start-up' section).
2. Shut down the plant again and let it heat up until the condensation water has dried off.
3. Insulate the regulator and pipes conveying the process medium using insulation material with a water vapor barrier. Use a stable sleeve to protect the external set point springs against touching or friction and include it in the insulation. If a control line is to be routed through the insulation, special care must be taken with the sealing since slight changes in shape may occur. The insulation thickness depends on the medium temperature and the ambient conditions. 50 mm is a typical thickness.

! NOTICE

Risk of regulator damage due to incorrect insulation.

- *The actuator must be insulated for medium temperatures below 0 °C.*
 - *The regulator must only be insulated up to the bottom section with balancing bellows or up to the connection of the actuator for medium temperatures above 80 °C.*
-

6 Start-up

The work described in this section is only to be performed by personnel appropriately qualified to carry out such tasks.

⚠ WARNING

Risk of personal injury due to pressurized components and process medium being discharged.

Incorrect opening of pressure equipment or mounting parts may lead to the process medium escaping to the atmosphere.

- *Do not loosen the control line while the valve is pressurized.*
- *Do not start up the regulator until all parts have been mounted.*

⚠ WARNING

Risk of burn injuries due to hot or cold components and pipeline.

Regulator components and the pipeline may become very hot or cold. Risk of burn injuries.

- *Allow components and pipelines to cool down or warm up to the ambient temperature.*
- *Wear protective clothing and safety gloves.*

⚠ WARNING

Risk of hearing loss or deafness due to loud noise.

Noise emission (e.g. cavitation) may occur during operation caused by the process medium and the operating conditions.

- *Wear hearing protection when working near the valve. Follow the instructions given by the plant operator.*

Before start-up or putting the device back into service, make sure the following conditions are met:

- The regulator is properly installed into the pipeline (see the 'Installation' section).
- The leak and function tests have been completed successfully (see the 'Testing the regulator' section).
- The prevailing conditions in the plant section concerned meet the regulator sizing requirements (see information under 'Intended use' in the 'Safety instructions and measures' section).

6.1 Start-up and putting the device back into operation

1. Depending on the field of application, allow the regulator to cool down or warm up to reach ambient temperature before start up.
2. All consumer valves are open.
3. Open the shut-off valves slowly over a time period of several minutes. Slowly opening these valves prevents a sudden surge in pressure which can damage the regulator parts.
4. Check the regulator to ensure it functions properly (see information under 'Adjusting the differential pressure set point' in the 'Operation' section).

Start-up

Before starting up the plant, make sure the following conditions are met:

- The control lines are open (needle valve) and correctly connected.

6.2 Starting up the plant

1. The plant (e.g. consumer valve) must be open while the plant is being filled.
2. The control lines are open (needle valve) and correctly connected.
3. Open the shut-off valves **slowly** over a time period of several minutes starting from the upstream pressure side. Fill the plant with the medium.
4. Make sure that the pressure rises simultaneously upstream and downstream of the regulator to avoid damaging the balancing bellows or diaphragm.

7 Operation

⚠ WARNING

Risk of burn injuries due to hot or cold components and pipeline.

Regulator components and the pipeline may become very hot or cold. Risk of burn injuries.

- Allow components and pipelines to cool down or warm up to the ambient temperature.
- Wear protective clothing and safety gloves.

⚠ WARNING

Risk of personal injury due to pressurized components and process medium being discharged.

Incorrect opening of pressure equipment or mounting parts may lead to the process medium escaping to the atmosphere.

- Do not loosen the control line while the valve is pressurized.
- Do not start up the regulator until all parts have been mounted.

⚠ WARNING

Risk of hearing loss or deafness due to loud noise.

Noise emission (e.g. cavitation) may occur during operation caused by the process medium and the operating conditions.

- Wear hearing protection when working near the valve. Follow the instructions given by the plant operator.

Immediately after completing start-up or placing the regulator back into service (see the 'Start-up' section), the regulator is ready for use.

7.1 Adjusting the set points

→ See Fig. 7-1 and Fig. 7-2.

The following rule applies to all differential pressure regulators with flow limitation: first adjust the differential pressure and the flow limitation afterwards.

7.1.1 Adjusting the differential pressure set point

The differential pressure set point can only be adjusted on the Type 42-34 Regulator. The differential pressure set point of the Type 42-38 Regulator is determined by the internal set point springs (16).

- The control and shut-off valves as well as all consumers or a bypass valve (if installed) must be open.

i Note

We recommend adjusting the regulator at an operating point at which the consumer valve is open by approximately 5 %. This results in the highest controlled differential pressure.

Operation

Procedure for the Type 42-34 Regulator

Adjust the required set point by tensioning the set point springs (16) at the set point adjuster (17).

For smaller differential pressure set points, we recommend using a differential pressure pressure gauge instead of the pressure gauges (3 and 5) to check the pressure.

5. Close the motorized valve.
6. Unscrew the cap (1.3) and undo the lock nut (1.2).
7. Turn the flow set point screw (1.1) counterclockwise (↺) as far as it will go (fully open) to deactivate the flow limitation.
8. Relieve the tension from the set point springs (16).

9. Slightly open the motorized valve (approx. 10 % valve travel). See Fig. 7-1.
10. Adjust the differential pressure by turning the set point adjuster (17) to load the set point springs.
 - Turn the set point adjuster (17) clockwise (↻) to increase the pressure set point.
 - Turn the set point adjuster (17) counterclockwise (↺) to reduce the pressure set point.

Change the plant throughput (e.g. by opening and closing the consumer valve) to check the adjusted differential pressure at the regulator. Correct it, if necessary.

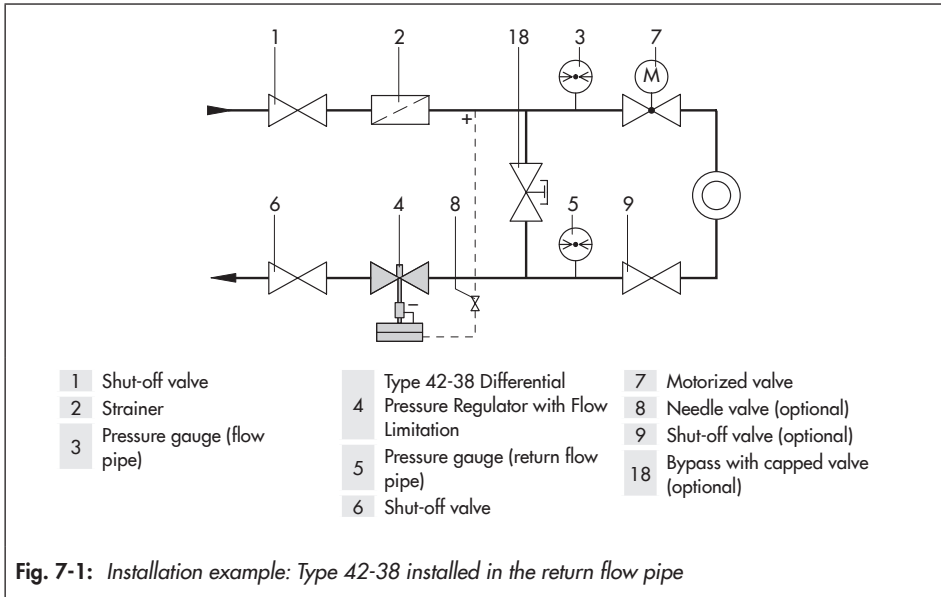

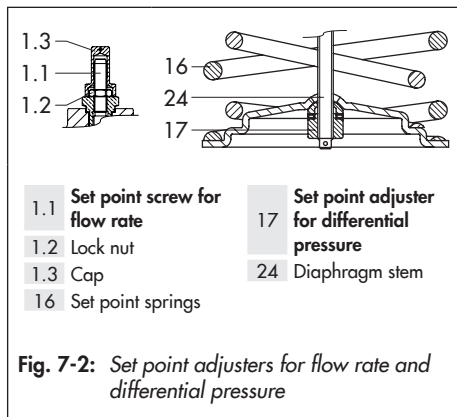

7.1.2 Adjusting the flow limitation

NOTICE

Set point adjustment is always based on a closed restriction (1.4).

How to proceed:

1. Unscrew the cap (1.3) and undo lock nut (1.2).
2. Turn the set point screw (1.1) clockwise to block the flow.
3. To achieve the maximum flow rate, all control and shut-off valves as well as all consumers including the motorized valve must be open (to ensure minimum drag in the plant).
4. Close the bypass valve, if installed.
5. Adjust the set point (see Table 7-2 and Table 7-3) by turning the set point screw

(1.1) one turn at a time. Check the flow rate at the heat meter (reading of flow measuring unit). Adjust the flow rate in smaller steps until the required flow rate is constant ($\pm 2\%$ deviations are generally acceptable).

Increase the differential pressure set point if the maximum flow rate is not reached.

6. After reaching the required flow rate, secure the set point screw (1.1) using the lock nut (1.2). Screw cap (1.3) back on.

7. Lead-seal the valve and actuator.

To adjust the flow rate limit when the pressure drop across the plant is known, use the adjustment diagrams for water (Fig. 7-4 to Fig. 7-9).

Note

Using the set point screw (1.1)

– Turn clockwise (↻):

The restriction closes. The flow rate drops.

– Turn counterclockwise (↺):

The restriction opens. The flow rate rises.

Note

We recommend adjusting the flow rate with the aid of a heat meter.

7.1.3 Based on a known plant pressure drop

To adjust the flow rate limit when the pressure drop of the plant is known, use the adjustment diagrams for water (Fig. 7-4 to Fig. 7-9).

How to proceed:

1. Unscrew the cap (1.3).
2. Undo lock nut (1.2) and turn the set point screw (1.1) clockwise as far as it will go to close the restriction.
3. Adjust the flow rate according to the value determined (number of turns in counterclockwise direction ☺).
4. Secure restriction setting using the lock nut (1.2) at the set point screw (1.1). Screw cap (1.3) back on.
5. Lead-seal the set point screw at the cap (1.3).

NOTICE

To determine the flow limitation to be adjusted and for Type 42-34 additionally the differential pressure set point, the differential pressure across the restriction ($\Delta p_{\text{restriction}}$) must be added to the known pressure drop across the plant (Δp_{plant}). From experience, the differential pressure at the restriction is assumed to be 0.2 bar.

The curves of the flow ranges in the following diagrams (Fig. 7-9 to Fig. 7-4) apply to 0.1, 0.2 and 0.5 bar.

7.1.4 Based on an unknown plant pressure drop

To adjust the flow rate limit when the pressure drop across the plant is not known.

Procedure

1. Unscrew the cap (1.3).
2. Undo lock nut (1.2) and turn the set point screw (1.1) clockwise (☺) to close the restriction.
3. Completely open the motorized valve.
4. Open the restriction initially one turn at a time. Check the flow rate at the heat meter (reading of flow measuring unit). Adjust the flow rate in smaller steps until the required flow rate is constant (2 % deviations are generally acceptable).
If the maximum flow rate is not reached, the differential pressure set point (in Type 42-34) must be increased.
5. After reaching the required flow rate, secure the restriction setting using the lock nut (1.2). Screw cap (1.3) back on.
6. Lead-seal the set point screw at the cap (1.3).
7. Lead-seal the actuator at the spindle.

7.2 Pressure conditions in the plant and at the regulator

On selecting the differential pressure set point or set point range, note that the differential pressure set point ($\Delta p_{\text{set point}}$) results from the known pressure drop across the fully open plant (Δp_{plant}) and the differential pressure created at the restriction ($\Delta p_{\text{restriction}}$). See Fig. 7-3.

The flow rate set points for water at a differential pressure at the restriction $\Delta p_{\text{restriction}}$ of 0.1, 0.2 and 0.5 bar are specified in Table 7-2 and Table 7-3.

$$\Delta p_{\text{set point}} = \Delta p_{\text{plant}} + \Delta p_{\text{restriction}}$$

The minimum required differential pressure Δp_{min} across the valve is calculated as follows:

$$\Delta p_{\text{min}} = \Delta p_{\text{set point}} + \left(\frac{\dot{V}}{K_{VS}} \right)^2$$

- Δp_{min} Minimum differential pressure across the valve in bar
- $\Delta p_{\text{restriction}}$ Differential pressure created at the restriction for measuring the flow rate
- $\Delta p_{\text{set point}}$ Differential pressure set point in bar
- Δp_{plant} Differential pressure (pressure loss) when the plant is completely open in bar
- \dot{V} Adjusted flow rate in m³/h
- K_{VS} Valve flow coefficient in m³/h

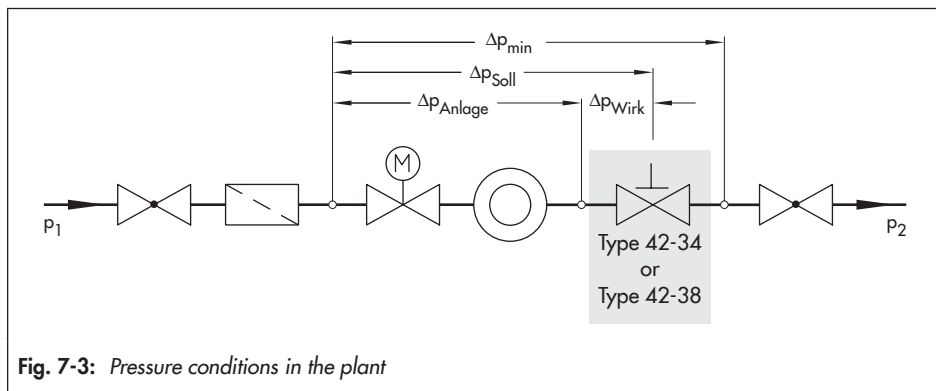

Fig. 7-3: Pressure conditions in the plant

7.3 Sample application

Adjusting the flow limitation (medium: water) when the pressure loss across the plant is known.

Known:

- A **Type 46-34, DN 25**, set point range from **0.25 to 3.5 m³/h** is to be used to limit the flow rate in the plant to **3.0 m³/h**.
- The pressure loss across the plant (Δp_{plant}) is **0.4 bar**.
- Determine the adjustment values using the adjustment diagram Fig. 7-4 on page 7-7.

To be determined:

What is the limit value of the differential pressure set point and how many turns of the set point screw are necessary?

Solution:

Sequence: points **A** to **E** in diagram (Fig. 7-4).

The calculation is based on the **pressure drop** Δp across the plant, therefore, this value must be known.

$\Delta p = 0.4 \text{ bar}$ is specified in the example and corresponds with **point A** in the diagram. The differential pressure at the restriction ($\Delta p_{\text{restriction}}$) assumed to be **0.2 bar** in the example, must be added.

A line representing this value is drawn from **A** across to the right and results in point **B**. **Point B** is situated on the same straight line for the differential pressure **$\Delta p = 0.6 \text{ bar}$** . See section 7.1.1.

! NOTICE

To adjust the differential pressure according to the adjustment diagrams (Fig. 7-4 to Fig. 7-9), it must be possible to also adjust the actuator set point required in addition to the calculated value.

- *Select the set point range after calculating the required differential pressure.*
-

A vertical line is drawn from **point B** until it reaches the limiting curve for the flow rate (in the example, it is 3.0 m³/h). This is **point C**.

The horizontal line is drawn from **point C** across to the curve relevant for the nominal size (DN) or K_{VS} coefficient used; this is **point D**.

When a line is drawn vertically upwards from **point D**, this results in **point E** which indicates how many turns of the set point screw are required.

The example shows that around **1.9 turns** are required.

Based on a closed restriction, turn the set point screw (1.1) **1.9 turns** counterclockwise \cup to open the restriction.

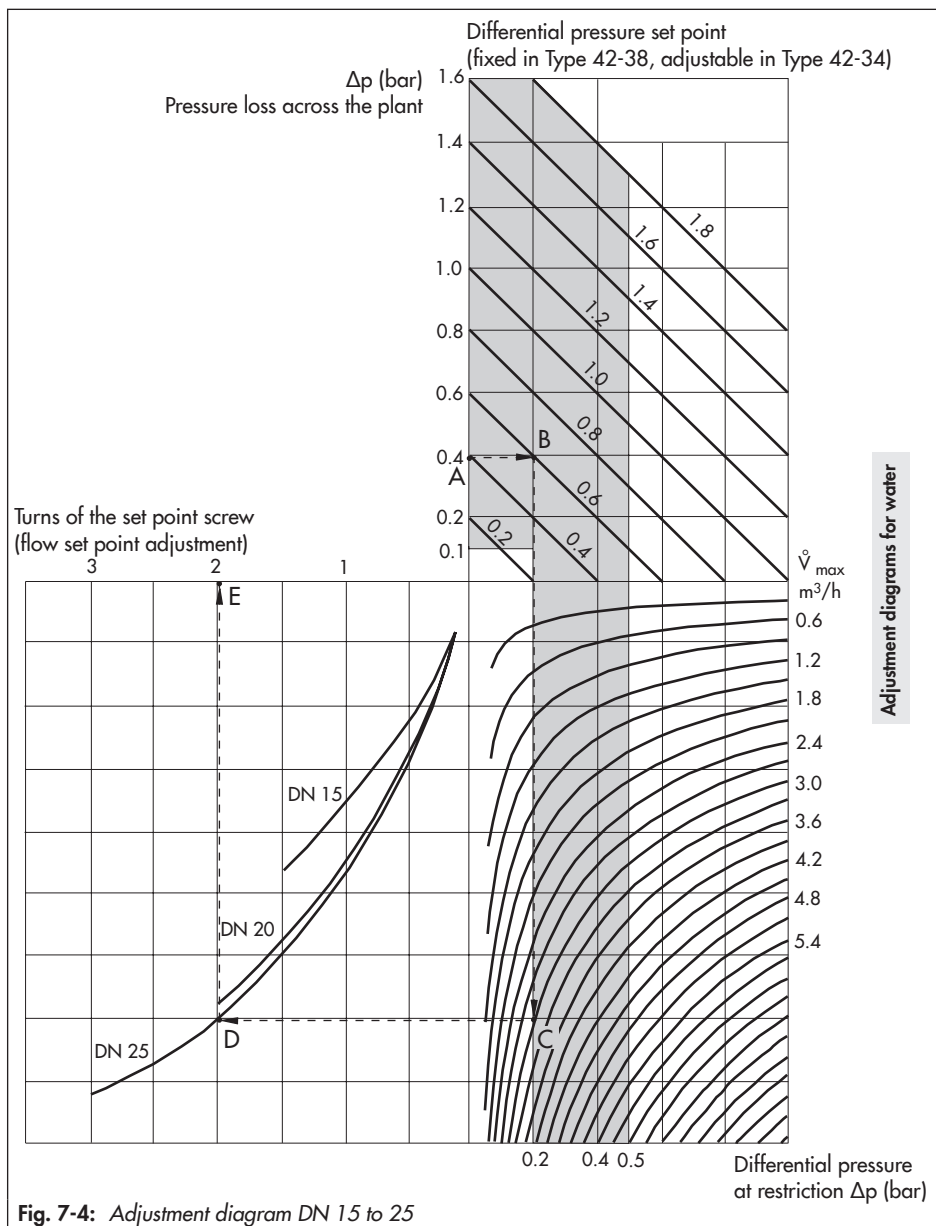

Fig. 7-4: Adjustment diagram DN 15 to 25

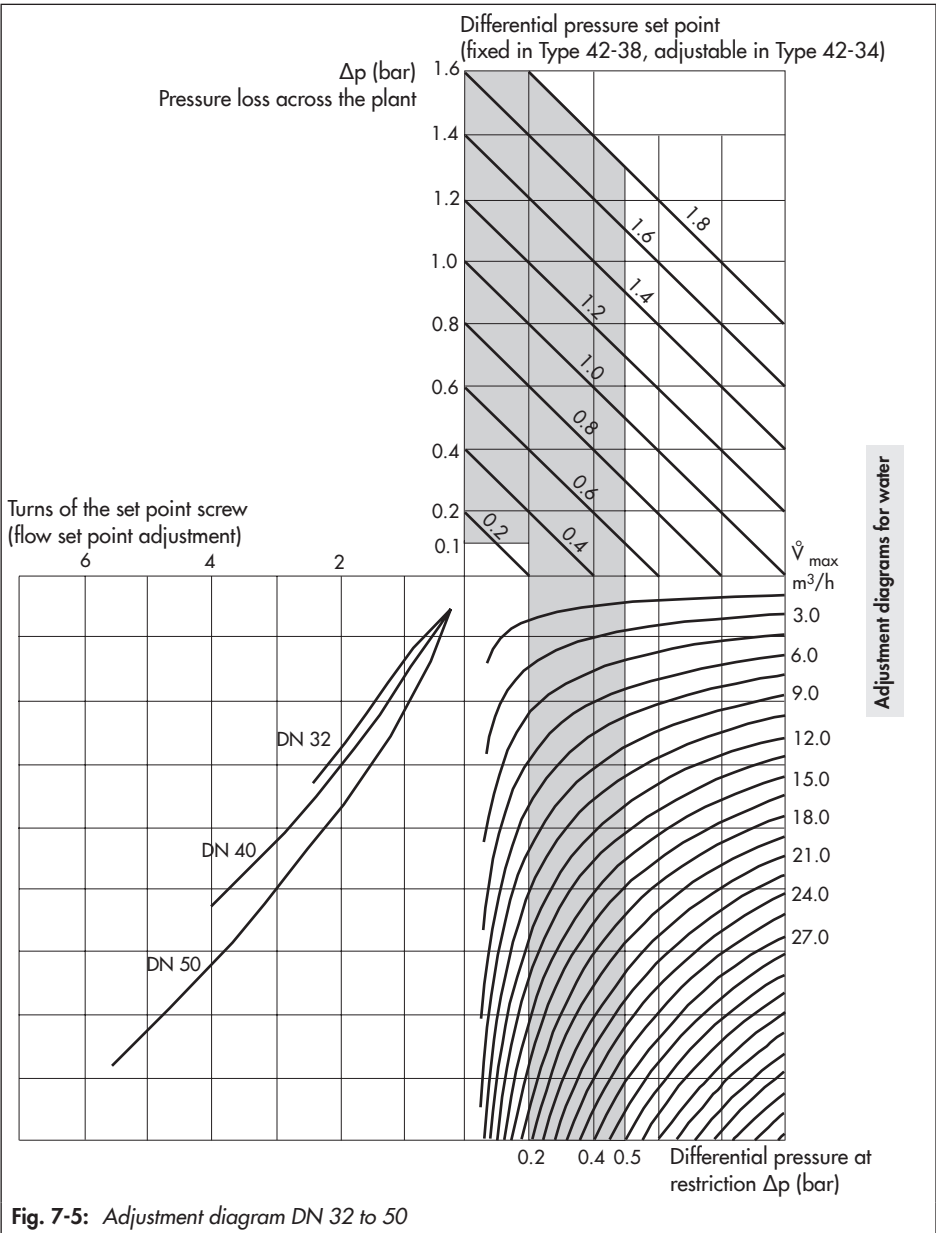

Fig. 7-5: Adjustment diagram DN 32 to 50

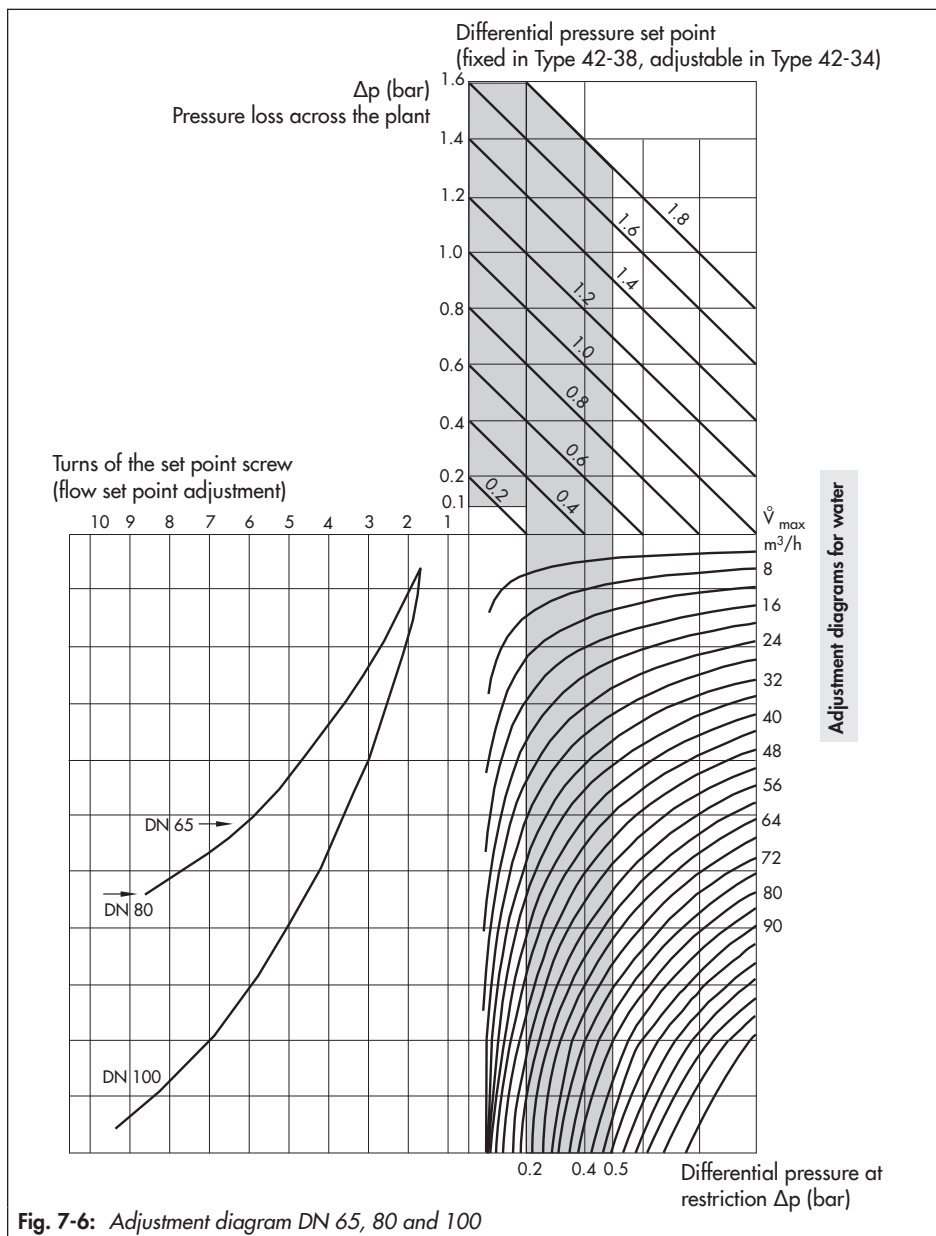

Fig. 7-6: Adjustment diagram DN 65, 80 and 100

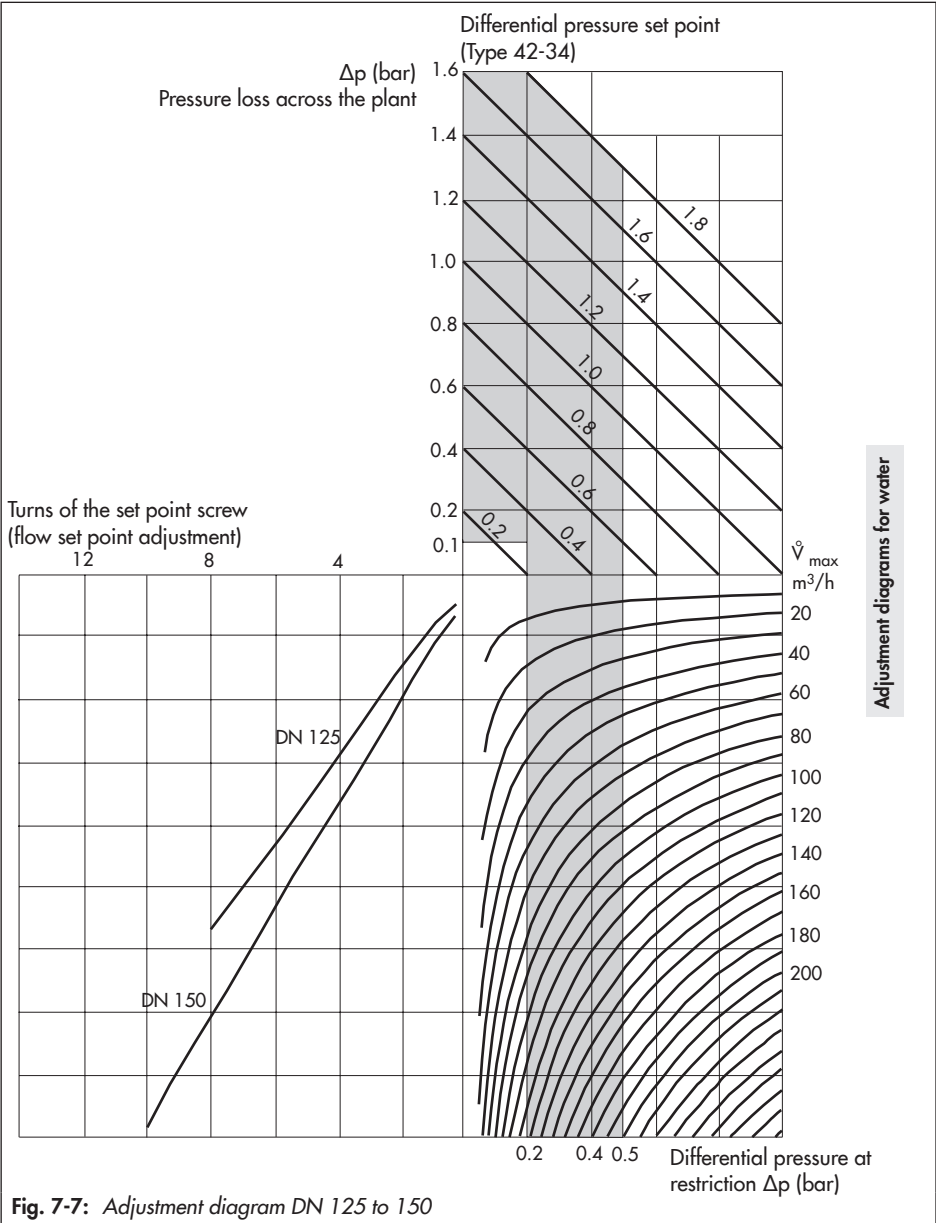
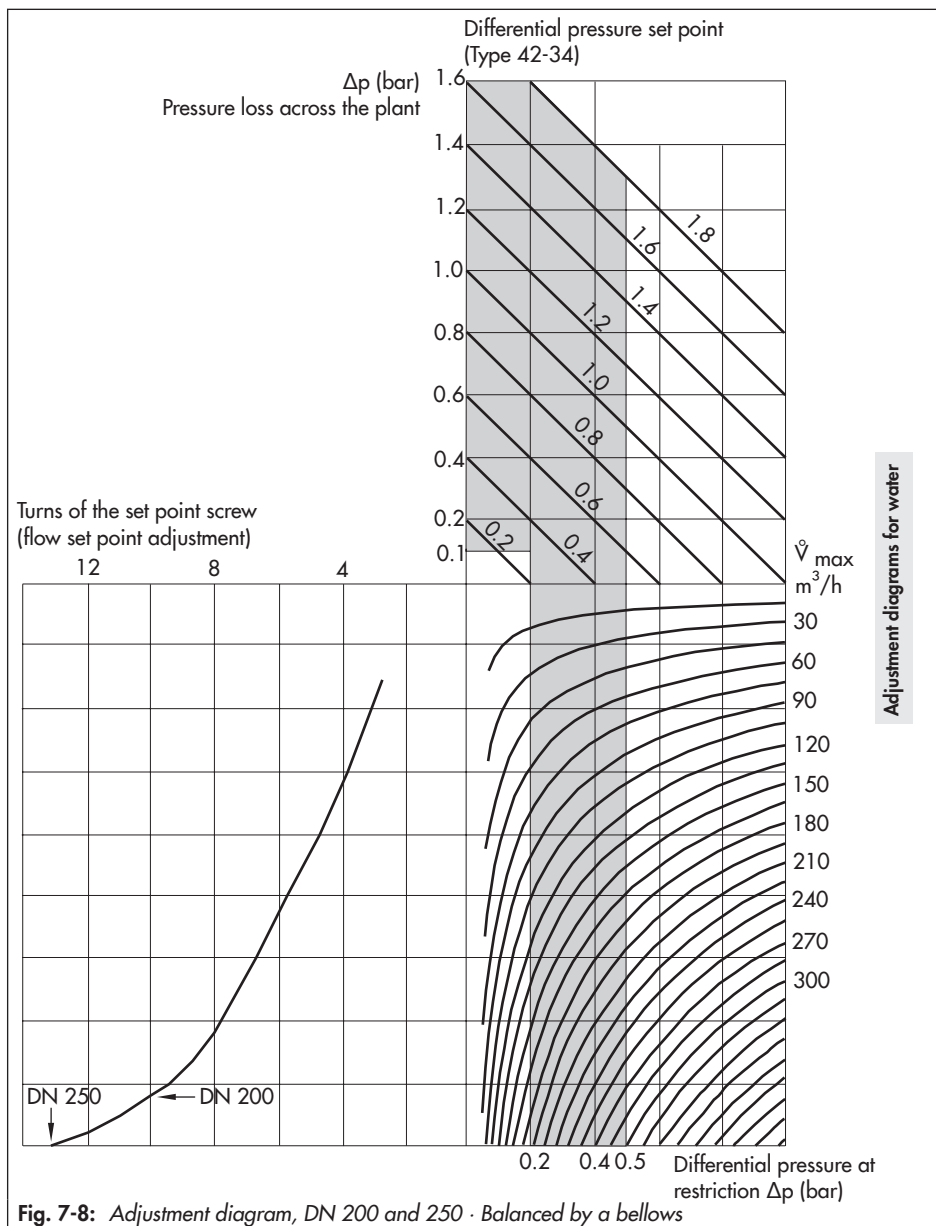

Fig. 7-7: Adjustment diagram DN 125 to 150



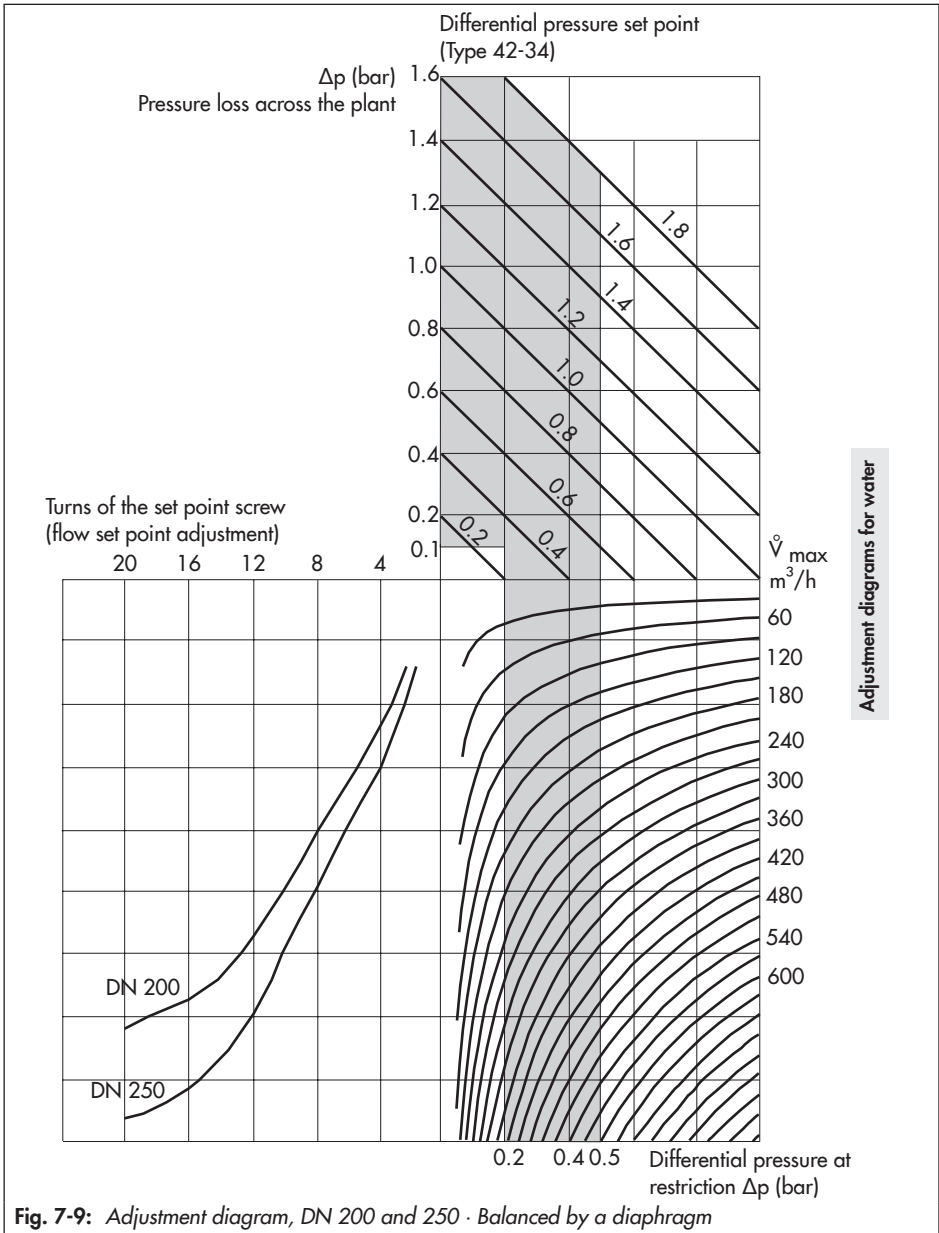

Fig. 7-9: Adjustment diagram, DN 200 and 250 · Balanced by a diaphragm

Table 7-2: Flow rate set point ranges for water · Type 2423 Valve, balanced by a bellows

$\Delta p_{\text{set point}}$	Δp_{plant}	$\Delta p_{\text{restriction}}$	DN	15	20	25	32	40	50	65	80	100	125	150	200	250
			\dot{V} Min.	0.05	0.15	0.25	0.4	0.6	0.9	2	3.5	6.5	11	18	20	26
0.2 bar	0.1 bar	0.1 bar	\dot{V} Max.	1.4	2.1	2.4	4.9	7.7	11.2	19	28	44	56	84	126	154
0.5 bar	0.3 bar	0.2 bar	\dot{V} Max.	2	3	3.5	7	11	16	28	40	63	80	120	180	220
1.0 bar	0.5 bar	0.5 bar	\dot{V} Max.	3	4.5	5.3	9.5	16	24	40	58	90	120	180	260	300
Max. permissible differential pressure Δp				25 bar					20 bar		16 bar		12 bar		10 bar	

Table 7-3: Flow rate set point ranges for water · Type 2423 Valve, balanced by a diaphragm

Valve size	DN	65	80	100	125	150	200	250
Differential pressure across restriction $\Delta p_{\text{restriction}}$	0.2 bar	2 to 28	3.5 to 35 ¹⁾	6.5 to 63	11 to 120	18 to 180	20 to 320	26 to 350
	0.5 bar	3.5 to 40	6.5 to 55	11 to 90	18 to 180	20 to 260	26 to 450	30 to 520
Max. permissible differential pressure Δp		10 bar			12 bar		10 bar	

¹⁾ 7 to 35 m³/h (160 cm² actuator), 7 to 40 m³/h (320 cm² actuator)

8 Malfunctions

8.1 Troubleshooting

Malfunction	Possible reasons	Recommended action
Flow rate or differential pressure exceeds adjusted set point	Insufficient pressure pulses on the operating diaphragm	→ Clean the control line and screw fittings.
	Foreign particles blocking the plug	→ Remove foreign particles. → Replace damaged parts. → Contact SAMSON's After-sales Service.
	Seat and plug are worn or leak.	→ Replace the damaged seat and plug. → Contact SAMSON's After-sales Service.
	Regulator and its K_{VS}/C_V coefficient too large for control task (flow rate) or too small (differential pressure)	→ Check the sizing. → Change K_{VS}/C_V coefficient, if necessary or install a different sized regulator. → Contact SAMSON's After-sales Service.
	Safety device, e.g. pressure limiter, has been triggered	→ Check plant. If necessary, unlock safety device.
	Pressure tapped at the wrong place.	→ Reconnect control lines at a different place. Do not tap pressure at pipe bends or necks.
	Defective operating diaphragm	→ Replace damaged diaphragm.
Differential pressure fluctuates.	Regulator or K_{VS}/C_V coefficient too large	→ Check the sizing. → Change K_{VS}/C_V coefficient, if necessary or install a different sized regulator. → Contact SAMSON's After-sales Service.
	The restriction in the control line for pressure tapping is too large or missing.	→ Install a restriction. → Install a smaller restriction.
Slow control response	Restriction in the screw joint of the actuator dirty or too small	→ Do not close the screw joint with restriction completely. → Clean screw joint or install larger screw joint.
	Dirt in the control line	→ Clean the control line.
Jerky control response	Increased friction, e.g. due to foreign particles between seat and plug	→ Remove foreign particles. → Replace damaged parts. → Contact SAMSON's After-sales Service.

Malfunctions

Malfunction	Possible reasons	Recommended action
Flow or differential pressure set point not reached	Regulator installed against the flow	→ Install the regulator so that the direction of flow matches the direction indicated by the arrow on the body.
	Plant differential pressure Δp too low	→ Compare differential pressure in the plant with the plant's drag. Plant differential pressure $\Delta p_{\min} = \Delta p_{\text{restriction}} + (V/K_{VS})^2$
	Regulator or K_{VS}/C_V coefficient too large	→ Check the sizing. → Change K_{VS}/C_V coefficient, if necessary or install a different sized regulator. → Contact SAMSON's After-sales Service.
	Safety device, e.g. pressure limiter, has been triggered	→ Check plant. If necessary, unlock safety device.
	Incorrect set point range selected	→ Check set point range → Contact SAMSON's After-sales Service.
	Foreign particles blocking the plug	→ Remove foreign particles. → Replace damaged parts. → Contact SAMSON's After-sales Service.
	Control line blocked	→ Clean the control line and screw fittings.
	Strainer blocked	→ Clean the strainer.
	Defective operating diaphragm	→ Replace damaged diaphragm.
Loud noises	High flow velocity, cavitation → Check the sizing. → Install larger regulator, if necessary.	

i Note

Contact SAMSON's After-sales Service for malfunctions not listed in the table.

The malfunctions listed in section 8.1 are caused by mechanical faults and incorrect regulator sizing. In the simplest case, the functioning can be restored following the recommended action. Special tools may be required to rectify the fault.

Exceptional operating and installation conditions may lead to changed situations that may affect the control response and lead to malfunctions. For troubleshooting, the conditions, such as installation, process medium, temperature and pressure conditions, must be taken into account.

**Tip**

SAMSON's After-sales Service can support you in drawing up an inspection and test plan for your plant.

8.2 Emergency action

Plant operators are responsible for emergency action to be taken in the plant.

We recommend removing the regulator from the pipeline before repairing it.

In the event of a regulator malfunction:

1. Close the shut-off valves upstream and downstream of the regulator to stop the process medium from flowing through the regulator.
2. Perform troubleshooting (see section 8.1).

3. Rectify those malfunctions that can be remedied based on the instructions provided here. Contact SAMSON's After-sales Service in all other cases.

Putting the regulator back into operation after a malfunction

See the 'Start-up' section.

9 Servicing

The regulator does not require any maintenance. Nevertheless, it is subject to natural wear, particularly at the seat, plug and operating diaphragm. Depending on the operating conditions, check the regulator at regular intervals to avoid possible malfunctions.

Plant operators are responsible for drawing up an inspection and test plan. Details on faults and how to remedy them can be found in the 'Malfunctions' section.

The work described in this section is only to be performed by personnel appropriately qualified to carry out such tasks.

We recommend removing the regulator from the pipeline before performing any maintenance or service work.

⚠ DANGER

Danger due to suspended loads falling.

- *Stay clear of suspended or moving loads.*
 - *Close off and secure the transport paths.*
-

⚠ WARNING

Risk of burn injuries due to hot or cold components and pipeline.

Regulator components and the pipeline may become very hot or cold. Risk of burn injuries.

- *Allow components and pipelines to cool down or warm up to the ambient temperature.*
 - *Wear protective clothing and safety gloves.*
-

⚠ WARNING

Risk of personal injury due to residual process medium in the regulator.

While working on the regulator, residual process medium can escape and, depending on its properties, may lead to personal injury, e.g. (chemical) burns.

- *Wear protective clothing, safety gloves and eye protection.*
-

⚠ WARNING

Risk of personal injury due to the regulator tipping.

- *Observe the regulator's center of gravity.*
 - *Secure the regulator against tipping over or turning.*
-

⚠ WARNING

Risk of injury due to incorrect lifting without the use of lifting equipment.

Lifting the regulator without the use of lifting equipment may lead to injuries (back injury in particular) depending on the weight of the regulator and/or actuator.

- Observe the occupational health and safety regulations valid in the country of use.
 - Observe the guideline weight for manual handling: 15 to max. 55 kg per person taking into account age, gender and physical fitness.
 - When the actuator is filled with medium, take the weight of the medium also into account.
 - Refer to the 'Design and principle of operation' section for the weights of the regulator and actuator.
-

⚠ WARNING

Risk of lifting equipment tipping over and risk of damage to lifting accessories due to exceeding the rated lifting capacity.

- Only use approved lifting equipment and accessories whose minimum lifting capacity is higher than the weight of the valve (including actuator and packaging, if applicable).
 - Refer to the 'Design and principle of operation' section for the weights.
-

📌 NOTICE

Risk of regulator damage due to excessively high or low tightening torques.

Observe the specified torques when tightening regulator components. Excessive tightening torques lead to parts wearing out more quickly. Parts that are too loose may cause leakage.

- Observe the specified tightening torques (see 'Tightening torques' in Annex).
-

📌 NOTICE

Risk of regulator damage due to the use of unsuitable tools.

- Only use tools approved by SAMSON (see 'Tools' in Annex).
-

📌 NOTICE

Risk of regulator damage due to the use of unsuitable lubricants.

- Only use lubricants approved by SAMSON (see 'Lubricants' in Annex).
-

i Note

The regulator was checked by SAMSON before it left the factory.

- *Certain test results certified by SAMSON lose their validity when the regulator is opened. Such testing includes seat leakage and leak tests.*
 - *The product warranty becomes void if service or repair work not described in these instructions is performed without prior agreement by SAMSON's After-sales Service.*
 - *Only use original spare parts by SAMSON, which comply with the original specifications.*
-

💡 Tip

SAMSON's After-sales Service can support you in drawing up an inspection and test plan for your plant.

Type 2423 Valve, DN 15 to 250 · Balanced by a bellows

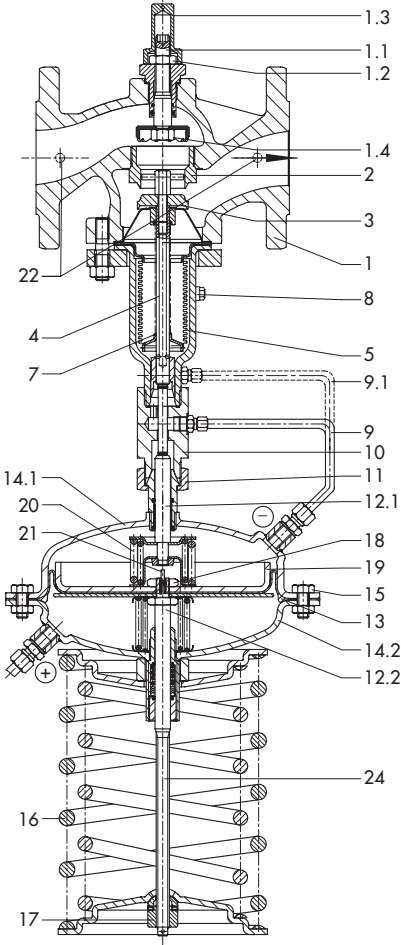

Type 2424 Actuator
Type 42-34

Type 2423 Valve
DN 15 to 100 · Balanced by a bellows

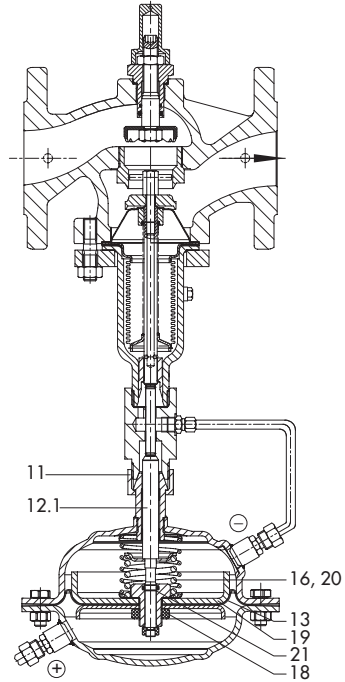

Type 2428 Actuator
Type 42-38

Fig. 9-1: Functional diagram for regulators, DN 15 to 250 with balancing bellows

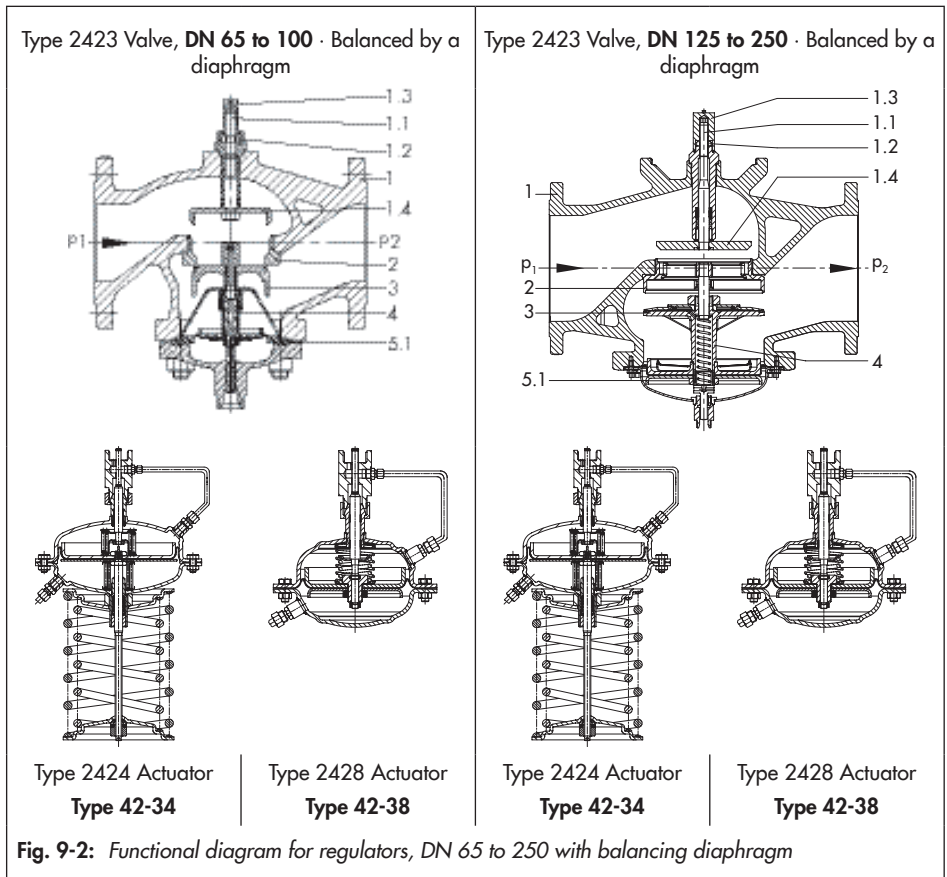

Legend for Fig. 9-1 and Fig. 9-2

1 Valve body	5.1 Balancing diaphragm	11 Coupling nut	17 Set point adjustment for differential pressure (set point adjuster)
Flow set point	7 Spring	12.1 Diaphragm stem	18 Nut
1.1 adjustment (set point screw)	8 Screw plug (balanced by a bellows, DN 125 and larger)	12.2 Diaphragm stem	19 Diaphragm plate
1.2 Lock nut	9 Low-pressure control line (up to DN 100)	13 Operating diaphragm	20 Force limiter
1.3 Cap	9.1 Low-pressure connection (DN 125 and larger)	14.1 Top diaphragm case (valve on top)	21 Internal excess pressure valve
1.4 Restriction	10 Connecting piece (up to DN 100)	14.2 Bottom diaphragm case (valve on top)	22 Blanking plug at side
2 Seat		15 Nuts and bolts	24 Diaphragm stem
3 Plug		16 Set point springs	
4 Plug stem			
5 Balancing bellows			

9.1 Preparing the valve for service work

1. Lay out the necessary material and tools to have them ready for the service work.
2. Put the regulator out of operation (see the 'Decommissioning' section).



Tip

We recommend removing the regulator from the pipeline before performing any service work (see the 'Removing the regulator from the pipeline' section).

The following service work can be performed after preparation is completed:

- Replace the actuator (see section 9.4)
- Replace the seat and plug (see section 9.5)
- Replace the actuator's operating diaphragm (see section 9.6)

9.2 Installing the regulator after service work

- Put the regulator back into operation (see the 'Start-up' section). Make sure the requirements and conditions for start-up or putting the valve back into operation are met.

9.3 Service work

- Before performing any service work, preparations must be made to the regulator (see section 9.1).
- After all service work is completed, check the regulator before putting it back into operation (see the 'Testing the regulator' section).

9.4 Replacing the actuator

- See Fig. 9-1 and Fig. 9-2

Removing the actuator

1. Put the regulator out of operation (see the 'Decommissioning' section).
2. Unscrew all control lines.
3. Unscrew the coupling nut (11) of the diaphragm actuator from the valve. Remove the actuator.

Mounting the actuator

1. Place the diaphragm actuator on the valve and fasten tight the coupling nut (11). Observe the specified tightening torques (see 'Tightening torques' in Annex).
2. Screw on all control lines. Observe the specified tightening torques (see 'Tightening torques' in Annex).
3. Put the regulator back into operation (see the 'Start-up' section).

9.5 Replacing the seat and plug

To replace seat and plug, contact SAMSON's After-sales Service.

Further information is available in Annex ('After-sales service').

9.6 Exchanging the operating diaphragm unit in the actuator



Tip

The associated order number is written on the actual operating diaphragm.

9.6.1 Type 2428 Actuator

→ See Fig. 9-1 and Fig. 9-2

Removing the operating diaphragm unit

1. Put the regulator out of operation (see the 'Decommissioning' section).
2. Unscrew all control lines.
3. Unscrew the coupling nut (11) of the diaphragm actuator from the valve. Remove the actuator.
4. Clamp the coupling nut (11) of the actuator into a suitable fixture.
5. Unscrew nuts and bolts (15) from the actuator. Remove the bottom diaphragm case (14.2).

6. Pull the operating diaphragm unit (consisting of items 13, 18, 19, 21 and 24) out of the top diaphragm case (14.1).

Installing the operating diaphragm unit

1. Insert the new operating diaphragm unit into the top diaphragm case (14.1).
2. Place on the bottom diaphragm case (14.2).
3. Insert nuts and bolts (15) and tighten gradually in a crisscross pattern. Observe the specified tightening torques (see 'Tightening torques' in Annex).
4. Place the diaphragm actuator on the valve and fasten tight the coupling nut (11). Observe the specified tightening torques (see 'Tightening torques' in Annex).
5. Screw on all control lines. Observe the specified tightening torques (see 'Tightening torques' in Annex).
6. Put the regulator back into operation (see the 'Start-up' section).

9.6.2 Type 2424 Actuator

→ See Fig. 9-1 and Fig. 9-2

Removing the operating diaphragm unit

1. Put the regulator out of operation (see the 'Decommissioning' section).
2. Completely relieve the tension from the set point springs (16) by turning the set point adjuster (17) counterclockwise (↺).

⚠ WARNING

Stored energy in the set point springs can cause components to move in an uncontrolled manner resulting in injury to hands or fingers.

3. Unscrew all control lines.
 4. Unscrew the coupling nut (11) of the diaphragm actuator from the valve. Remove the actuator.
 5. Clamp the coupling nut (11) of the actuator into a suitable fixture.
 6. Lift off the set point adjuster (17) together with needle bearing, washer, spring plate and set point springs (16).
 7. Unscrew nuts and bolts (15) from the actuator. Lift off the bottom diaphragm case (14.2) including the operating diaphragm unit (consisting of items 13, 18, 19, 21 and 24).
 8. Pull the operating diaphragm unit out of the top diaphragm case (14.2). Exchange the operating diaphragm unit.
4. Place on the set point springs (16) together with spring plate, needle bearing and washer. Screw on the set point adjuster (17).
 5. Place the diaphragm actuator on the valve and fasten tight the coupling nut (11). Observe the specified tightening torques (see 'Tightening torques' in Annex).
 6. Screw on all control lines. Observe the specified tightening torques (see 'Tightening torques' in Annex).
 7. Put the regulator back into operation (see the 'Start-up' section).

Installing the operating diaphragm unit

1. Insert the new operating diaphragm unit into the bottom diaphragm case (14.2).
2. Place the bottom diaphragm case (14.2) with the new operating diaphragm unit onto the top diaphragm case (14.1).
3. Insert nuts and bolts (15) and tighten gradually in a crisscross pattern. Observe the specified tightening torques (see 'Tightening torques' in Annex).

9.7 Ordering spare parts and operating supplies

Contact your nearest SAMSON subsidiary or SAMSON's After-sales Service for information on spare parts, lubricants and tools.

Spare parts

See Annex for details on spare parts.

Lubricants

Contact SAMSON's After-sales Service for more information on lubricants.

Tools

Contact SAMSON's After-sales Service for more information on tools.

10 Decommissioning

The work described in this section is only to be performed by personnel appropriately qualified to carry out such tasks.

⚠ DANGER

Risk of bursting due to incorrect opening of pressurized equipment or components.

Regulators and pipelines are pressure equipment that may burst when handled incorrectly. Flying projectile fragments or the release of process medium under pressure can cause serious injury or even death.

Before working on the regulator:

- Depressurize all plant sections concerned and the regulator.
- Drain the process medium from all the plant sections concerned as well as the valve.

⚠ WARNING

Risk of burn injuries due to hot or cold components and pipeline.

Regulator components and the pipeline may become very hot or cold. Risk of burn injuries.

- Allow components and pipelines to cool down or warm up to the ambient temperature.
- Wear protective clothing and safety gloves.

⚠ WARNING

Risk of personal injury due to pressurized components and process medium being discharged.

Incorrect opening of pressure equipment or mounting parts may lead to the process medium escaping to the atmosphere.

- Do not loosen the control line while the valve is pressurized.
- Do not start up the regulator until all parts have been mounted.

⚠ WARNING

Risk of hearing loss or deafness due to loud noise.

Noise emission (e.g. cavitation) may occur during operation caused by the process medium and the operating conditions.

- Wear hearing protection when working near the valve. Follow the instructions given by the plant operator.

⚠ WARNING

Crush hazard arising from moving parts.

- Do not insert hands or fingers between the set point springs while the regulator is in operation.

Decommissioning

→ Before starting any work on the regulator, depressurize plant sections as well as the regulator.

WARNING

Risk of personal injury due to residual process medium in the regulator.

While working on the regulator, residual process medium can escape and, depending on its properties, may lead to personal injury, e.g. (chemical) burns.

→ *Wear protective clothing, safety gloves and eye protection.*

To decommission the regulator for service work or disassembly, proceed as follows:

1. Close the shut-off valve (1) on the upstream side of the regulator.
2. Close the shut-off valve (6) on the downstream side of the regulator.
3. Depressurize the plant.
4. Completely drain the pipelines and valve.
5. If necessary, allow the pipeline and regulator components to cool down or warm up to the ambient temperature.

11 Removal

The work described in this section is only to be performed by personnel appropriately qualified to carry out such tasks.

⚠ WARNING

Risk of burn injuries due to hot or cold components and pipeline.

Regulator components and the pipeline may become very hot or cold. Risk of burn injuries.

- *Allow components and pipelines to cool down or warm up to the ambient temperature.*
- *Wear protective clothing and safety gloves.*

⚠ WARNING

Risk of personal injury due to residual process medium in the regulator.

While working on the regulator, residual process medium can escape and, depending on its properties, may lead to personal injury, e.g. (chemical) burns.

- *Wear protective clothing, safety gloves and eye protection.*

Before removing the valve, make sure the following conditions are met:

- The regulator is put out of operation (see the 'Decommissioning' section).

11.1 Removing the regulator from the pipeline

1. Support the regulator to hold it in place when separated from the pipeline (see the 'Shipment and on-site transport' section).
2. Unbolt the flange joint.
3. Remove the regulator from the pipeline (see the 'Shipment and on-site transport' section).

11.2 Removing the actuator from the valve

See the 'Servicing' section.

12 Repairs

If the regulator does not function properly according to how it was originally sized or does not function at all, it is defective and must be repaired or exchanged.

! NOTICE

Risk of regulator damage due to incorrect service or repair work.

→ Contact SAMSON's After-sales Service for repair work.

12.1 Returning devices to SAMSON

Defective devices can be returned to SAMSON for repair.

Proceed as follows to return devices:

1. Exceptions apply concerning some special device models
 - ▶ www.samsongroup.com > Service & Support > After-sales Service.
2. Send an e-mail
 - ▶ retouren@samsongroup.com to register the return shipment including the following information:
 - Type
 - Material number
 - Item numbers of accessories
 - Original order
 - Completed Declaration on Contamination, which can be downloaded from our website at
 - ▶ www.samsongroup.com > Service & Support > After-sales Service.

After checking your registration, we will send you a return merchandise authorization (RMA).

3. Attach the RMA (together with the Declaration on Decontamination) to the outside of your shipment so that the documents are clearly visible.
4. Send the shipment to the address given on the RMA.

i Note

Further information on returned devices and how they are handled can be found at

▶ www.samsongroup.com > Service & Support > After-sales Service.

13 Disposal



SAMSON is a producer registered at the following European institution
▶ <https://www.ewrn.org/national-registers/national-registers>.
WEEE reg. no.:
DE 62194439/FR 025665

- Observe local, national and international refuse regulations.
- Do not dispose of components, lubricants and hazardous substances together with your other household waste.

i Note

We can provide you with a recycling passport according to PAS 1049 on request. Simply e-mail us at aftersaleservice@samsongroup.com giving details of your company address.

Tip

On request, we can appoint a service provider to dismantle and recycle the product as part of a distributor take-back scheme.

14 Certificates

The EU and UKCA declarations of conformity are included on the next pages:

- EU declaration of conformity in compliance with Pressure Equipment Directive 2014/68/EU on page 14-2.
- EU declaration of conformity in compliance with Machinery Directive 2006/42/EC for Type 42-34 and Type 42-38 Regulators on page 14-5.
- Declaration of incorporation in compliance with Machinery Directive 2006/42/EC for the Type 2423 Valve as well as Type 2424 and Type 2428 Actuators on page 14-7.
- UKCA declaration of conformity in compliance with Directive 2016 No. 1105 on page 14-10.
- UKCA declaration of conformity in compliance with Directive 2008 No. 1597 for Type 42-34 and Type 42-38 Regulators on page 14-12.
- Declaration of incorporation in compliance with Directive 2008 No. 1597 for the Type 2423 Valve as well as Type 2424 and Type 2428 Actuators on page 14-14.

14.1 Information on the UK sales region

The following information corresponds to the Pressure Equipment (Safety) Regulations 2016, STATUTORY INSTRUMENTS, 2016 No. 1105 (UKCA marking). It does not apply to Northern Ireland.

Importer

SAMSON Controls Ltd
 Perrywood Business Park
 Honeycrock Lane
 Redhill, Surrey RH1 5JQ
 Phone: +44 1737 766391
 E-mail: sales-uk@samsongroup.com
 Website: uk.samsongroup.com

EU DECLARATION OF CONFORMITY
TRANSLATION



Module H / N° CE-0062-PED-H-SAM 001-22-DEU

For the following products, SAMSON hereby declares under its sole responsibility:

Devices	Series	Type	Version
Three-way valve	---	2119	DIN EN, body, EN-GJL-250 and 1.0619, DN 150, PN 16, fluids G2, L2, L1 ¹⁾
			DIN EN, body, 1.0619, DN 100-150, PN 25, fluids G2, L2, L1 ¹⁾
			DIN EN, body, 1.0619 and 1.4408, DN 65-150, PN 40, fluids G2, L2, L1 ¹⁾
			ANSI, body, A216 WCC and A351 CF8M, NPS 6, Class 150, fluids G2, L2, L1 ¹⁾
			ANSI, body, A216 WCC and A351 CF8M, NPS 2-6, Class 300, fluids G2, L2, L1 ¹⁾
Self-operated Regulators	---	3222	DIN EN, body, CC499K, DN 50, PN 25, all fluids
Three-way valve	---	3260	DIN EN, body, EN-GJL-250, DN 250-300, PN 16, fluids G2, L2 ¹⁾
Globe valve Three-way valve	V2001	3531	DIN EN, body, 1.0619 and 1.4408, DN 50-80, PN 25, all fluids
		3535	ANSI, body, A216 WCC and A351 CF8M, NPS 2½-3, Class 150, all fluids
Control valve	---	3214	DIN EN, body, EN-GJL-250, DN 150-400, PN 16, fluids G2, L2, L1 ¹⁾
			DIN EN, body, EN-GJS-400-18-LT, DN 100-150, PN 25, fluids G2, L2, L1 ¹⁾
			DIN EN, body, 1.0619, DN 32-400, PN 40, all fluids
			ANSI, body, A126 B, NPS 6-10, Class 125, fluids G2, L2, L1 ¹⁾
			ANSI, body, A216 WCC, NPS 2½-10, Class 150, all fluids
Self-operated Regulators	42	2423	DIN EN, body, EN-GJL-250, DN 150-250, PN 16, fluids G2, L2, L1 ¹⁾
			DIN EN, body, EN-GJS-400-18-LT, DN 150, PN 16, fluids G2, L2, L1 ¹⁾
			DIN EN, body, EN-GJS-400-18-LT, DN 100-150, PN 25, fluids G2, L2, L1 ¹⁾
			DIN EN, body, 1.0619 and 1.4408, DN 65-250, PN 16, all fluids
			DIN EN, body, 1.0619 and 1.4408, DN 50-250, PN 25, all fluids
			DIN EN, body, 1.0619 and 1.4408, DN 32-250, PN 40, all fluids
			ANSI, body, A126 B, NPS 6-10, Class 125, fluids G2, L2, L1 ¹⁾
			ANSI, body, A216 WCC and A351 CF8M, NPS 2½-10, Class 150, all fluids
			ANSI, body, A216 WCC and A351 CF8M, NPS 1½-10, Class 300, all fluids
			DIN EN, body, EN-GJL-250, DN 150-400, PN 16, fluids G2, L2, L1 ¹⁾
			DIN EN, body, EN-GJS-400-18-LT, DN 100-150, PN 25, fluids G2, L2, L1 ¹⁾
			DIN EN, body, 1.0619 and 1.4408, DN 65-400, PN 16, all fluids
	DIN EN, body, 1.0619 and 1.4408, DN 200-400, PN 25, all fluids		
	DIN EN, body, 1.0619 and 1.4408, DN 32-400, PN 40, all fluids		
	DIN EN, body, 1.0460, DN 40-50, PN 40, all Fluids		
	DIN EN, body, 1.6220+QT, DN 65-250, PN 16, all fluids		
	DIN EN, body, 1.6220+QT, DN 200-250, PN 25, all fluids		
	DIN EN, body, 1.6220+QT, DN 32-250, PN 40, all fluids		
	ANSI, body, A126 B, NPS 6-16, Class 125, fluids G2, L2, L1 ¹⁾		
	ANSI, body, A216 WCC and A351CF8M, NPS 2½-16, Class 150, all fluids		
	ANSI, body, A216 WCC and A351CF8M, NPS 1½-16, Class 300, all fluids		
	ANSI, body, A105, NPS 1½-2, Class 300, all fluids		
	ANSI, body, A352 LCC, NPS 2½-10, Class 150, all fluids		
	ANSI, body, A352 LCC, NPS 1½-10, Class 300, all fluids		
	42	2421RS	DIN EN, body, 1.0619 and 1.4408, DN 65-150, PN 16, all fluids
			DIN EN, body, 1.0619 and 1.4408, DN 50-150, PN 25, all fluids
			DIN EN, body, 1.0619 and 1.4408, DN 32-150, PN 40, all fluids
DIN EN, body, 1.4571 and 1.4401/1.4404, DN 50, PN 25, all fluids			
DIN EN, body, 1.4571 and 1.4401/1.4404, DN 32-50, PN 40, all fluids			
ANSI, body, A216 WCC and A351 CF8M, NPS 2½-6, Class 150, all fluids			
ANSI, body, A216 WCC and A351 CF8M, NPS 1½-6, Class 300, all fluids			

Revision 00

Classification: Public · SAMSON AKTIENGESELLSCHAFT · Weismuellerstrasse 3 · 60314 Frankfurt am Main, Germany

Page 1 of 3

EU DECLARATION OF CONFORMITY
TRANSLATION



Devices	Series	Type	Version	
Self-operated Regulators	40	2405	DIN EN, body, 1.0619, 1.4571, 1.4404, 1.4408, 1.0460, DN 32-50, PN40, all fluids	
			ANSI, body, A105, A182 F316L, A351 CF8M, A216 WCC, NPS 1½-2, Class 300, all fluids	
		2406	DIN EN, body, EN-GJL-250, DN 150, PN 16, fluids G2, L2, L1 ¹⁾	
			DIN EN, body, 1.0619 and 1.4408, DN 32-150, PN 40, all fluids	
			DIN EN, body, 1.0460 and 1.4404, DN 32-50, PN 40, all fluids	
			ANSI, body, A126 B, NPS 6, Class 125, fluids G2, L2, L1 ¹⁾	
			ANSI, body, A216 WCC and A351 CF8M, NPS 2½-6, Class 150, all fluids	
			ANSI, body, A216 WCC and A351 CF8M, NPS 1½-6, Class 300, all fluids	
			ANSI, body, A105 and A182 F316L, NPS 1½-2, Class 300, all fluids	
			DIN EN, body, EN-GJS-400-18-LT, DN 100, PN25, fluids G2, L2, L1 ¹⁾	
	41	2412 2417	DIN EN, body, 1.0619 and 1.4408, DN 32-100, PN 40, all fluids	
			DIN EN, body, 1.0460, 1.4571 and 1.4404, DN 32-80, PN 40, all fluids	
		---	2404-1	ANSI, body, A216 WCC and A351 CF8M, NPS 2½-4, Class 150, all fluids
				ANSI, body, A216 WCC and A351 CF8M, NPS 1½-4, Class 300, all fluids
			DIN EN, body, EN-GJL-250, DN 150, PN16, fluids G2, L2, L1 ¹⁾	
			DIN EN, body, 1.0619 and 1.4408, DN 32-150, PN 40, all fluids	
			ANSI, body, A126 B, NPS 6, Class 125, fluids G2, L2, L1 ¹⁾	
			ANSI, body, A216 WCC and A351 CF8M, NPS 2½-6, Class 150, all fluids	
			ANSI, body, A216 WCC and A351 CF8M, NPS 1½-6, Class 300, all fluids	
			DIN EN, body, EN-GJL-250, DN 150-400, PN 16, fluids G2, L2, L1 ¹⁾	
	---	2404-2	DIN EN, body, 1.0619 and 1.4408, DN 65-400, PN 16, all fluids	
			DIN EN, body, 1.0619 und 1.4408, DN 65-400, PN 40, all fluids	
		---	2331 2337	ANSI, body, A126 B, NPS 6-16, Class 125, fluids G2, L2, L1 ¹⁾
				ANSI, body, A216 WCC and A351 CF8M, NPS 2½-16, Class 150, all fluids
			ANSI, body, A216 WCC and A351 CF8M, NPS 2½-10, Class 300, all fluids	
			DIN EN, body, EN-GJL-250, DN 250, PN 16, fluids G2, L2 ¹⁾	
			DIN EN, body, 1.0619, DN 250, PN 16, fluids G2, L2 ¹⁾	
			DIN EN, body, 1.0619, DN 200-250, PN 25, fluids G2, L2 ¹⁾	
			DIN EN, body, 1.0619, DN 125-250, PN 40, fluids G2, L2 ¹⁾	
			DIN EN, body, EN-GJL-250, DN 150-400, PN 16, fluids G2, L2, L1 ¹⁾	
	---	2333 2335	DIN EN, body, EN-GJS-400-18-LT, DN 100-150, PN 25, fluids G2, L2, L1 ¹⁾	
			DIN EN, body, 1.0619 and 1.4408, DN 65-400, PN 16, all fluids	
		---	2334	DIN EN, body, 1.0619 and 1.4408, DN 200-400, PN 25, all fluids
				DIN EN, body, 1.0619 and 1.4408, DN 65-400, PN 40, all fluids
			ANSI, body, A126 B, NPS 6-16, Class 125, fluids G2, L2, L1 ¹⁾	
			ANSI, body, A216 WCC and A351 CF8M, NPS 2½-16, Class 150, all fluids	
			ANSI, body, A216 WCC and A351 CF8M, NPS 2½-16, Class 300, all fluids	
			DIN EN, body, EN-GJL-250, DN 150-400, PN 16, fluids G2, L2, L1 ¹⁾	
			DIN EN, body, EN-GJS-400-18-LT, DN 150, PN 16, fluids G2, L2, L1 ¹⁾	
			DIN EN, body, EN-GJS-400-18-LT, DN 100-150, PN 25, fluids G2, L2, L1 ¹⁾	
---	2373 2375	DIN EN, body, 1.0619 and 1.4408, DN 65-400, PN 16, all fluids		
		DIN EN, body, 1.0619 and 1.4408, DN 200-400, PN 25, all fluids		
	---	2602	DIN EN, body, 1.0619 and 1.4408, DN 65-400, PN 40, all fluids	
			ANSI, body, A126 B, NPS 6-16, Class 125, fluids G2, L2, L1 ¹⁾	
		ANSI, body, A216 WCC and A351 CF8M, NPS 2½-16, Class 150, all fluids		
		ANSI, body, A216 WCC and A351 CF8M, NPS 2½-16, Class 300, all fluids		
		DIN EN, body, 1.4469 and 1.4470, DN 32-50, PN 40, all fluids		
		ANSI, body, A995 5A and A995 4A, NPS 1½-2, Class 300, all fluids		
		DIN EN, body, EN-GJL-250, DN 150-250, PN 16, fluids G2, L2, L1 ¹⁾		
		DIN EN, body, EN-GJS-400-18-LT, DN 150, PN 16, fluids G2, L2, L1 ¹⁾		
Strainers	2N/2NI	2602	DIN EN, body, EN-GJS-400-18-LT, DN 100-150, PN 25, fluids G2, L2, L1 ¹⁾	
			DIN EN, body, 1.0619, DN 100-250, PN 16, all fluids	

Revision 00

Classification: Public · SAMSON AKTIENGESELLSCHAFT · Weismuellerstrasse 3 · 60314 Frankfurt am Main, Germany

Page 2 of 3

EU DECLARATION OF CONFORMITY
TRANSLATION



Devices	Series	Type	Version
Strainers	2N/2NI	2602	DIN EN, body, 1.0619, DN 200-250, PN 25, all fluids
			DIN EN, body, 1.0619, DN 32-250, PN 40, all fluids
			DIN EN, body, 1.4408, DN 65-100, PN 16, all fluids
			DIN EN, body, 1.4408, DN 32-100, PN 40, all fluids

¹⁾ Gases according to Article 4(1)(c.i), second indent
Liquids according to Article 4(1)(c.ii)

That the products mentioned above comply with the requirements of the following standards:

Directive of the European Parliament and of the Council on the harmonization of the laws of the Member States relating to the making available on the market of pressure equipment	2014/68/EU	of 15. May 2014
Applied conformity assessment procedure for fluids according to Article 4(1)	Module H	by Bureau Veritas 0062

The manufacturer's quality management system is monitored by the following notified body:
Bureau Veritas Services SAS, 8 Cours du Triangle, 92800 PUTEAUX – LA DEFENSE, FRANCE
Technical standards applied: DIN EN 12516-2, DIN EN 12516-3, ASME B16.34

Manufacturer: SAMSON AG, Weismuellerstrasse 3, 60314 Frankfurt am Main, Germany

Frankfurt am Main, 14. October 2022

ppa. Norbert Tollas

ppa. Norbert Tollas
Senior Vice President
Global Operations

i.v. P. Scheermesser

i.v. Peter Scheermesser
Director
Product Maintenance & Engineered Products

Revision 00

EU DECLARATION OF CONFORMITY
TRANSLATION



Declaration of Conformity of Final Machinery

in accordance with Annex II, section 1.A. of the Directive 2006/42/EC

For the following product:

Type 42-34 Differential Pressure Regulator with Flow Limitation consisting of Type 2423 Valve and Type 2424 Actuator

We hereby declare that the machinery mentioned above complies with all applicable requirements stipulated in Machinery Directive 2006/42/EC.

For product descriptions refer to:

- Type 42-34 and Type 42-38 Differential Pressure Regulators with Flow Limitation: Mounting and Operating Instructions EB 3013

Referenced technical standards and/or specifications:

- VCI, VDMA, VGB: "Leitfaden Maschinenrichtlinie (2006/42/EG) – Bedeutung für Armaturen, Mai 2018" [German only]
- VCI, VDMA, VGB: "Zusatzdokument zum Leitfaden Maschinenrichtlinie (2006/42/EG) – Bedeutung für Armaturen vom Mai 2018" [German only], based on DIN EN ISO 12100:2011-03

Comment:

Information on residual risks of the machinery can be found in the mounting and operating instructions of the valve and actuator as well as in the referenced documents listed in the mounting and operating instructions.

Persons authorized to compile the technical file:

SAMSON AG, Weismüllerstraße 3, 60314 Frankfurt am Main, Germany
Frankfurt am Main, 12 May 2022

Norbert Tollas
Senior Vice President
Global Operations

Peter Scheermesser
Director
Product Maintenance & Engineered Products

Revision no. 00

EU DECLARATION OF CONFORMITY
TRANSLATION



Declaration of Conformity of Final Machinery

in accordance with Annex II, section 1.A. of the Directive 2006/42/EC

For the following product:

**Type 42-38 Differential Pressure Regulator with Flow Limitation consisting of
Type 2423 Valve and Type 2428 Actuator**

We hereby declare that the machinery mentioned above complies with all applicable requirements stipulated in Machinery Directive 2006/42/EC.

For product descriptions refer to:

- Type 42-38 Differential Pressure Regulators with Flow Limitation:
Mounting and Operating Instructions EB 3013

Referenced technical standards and/or specifications:

- VCI, VDMA, VGB: "Leitfaden Maschinenrichtlinie (2006/42/EG) – Bedeutung für Armaturen, Mai 2018" [German only]
- VCI, VDMA, VGB: "Zusatzdokument zum Leitfaden Maschinenrichtlinie (2006/42/EG) – Bedeutung für Armaturen vom Mai 2018" [German only], based on DIN EN ISO 12100:2011-03

Comment:

Information on residual risks of the machinery can be found in the mounting and operating instructions of the valve and actuator as well as in the referenced documents listed in the mounting and operating instructions.

Persons authorized to compile the technical file:

SAMSON AG, Weismüllerstraße 3, 60314 Frankfurt am Main, Germany
Frankfurt am Main, 12 May 2022

Handwritten signature of Norbert Tollas in blue ink.

Norbert Tollas
Senior Vice President
Global Operations

Handwritten signature of Peter Scheermesser in blue ink.

Peter Scheermesser
Director
Product Maintenance & Engineered Products

Revision no. 00

DECLARATION OF INCORPORATION TRANSLATION



Declaration of Incorporation in Compliance with Machinery Directive 2006/42/EC

For the following product:
Type 2423 Valve

We certify that the Type 2423 Valve is partly completed machinery as defined in the Machinery Directive 2006/42/EC and that the safety requirements stipulated in Annex I, 1.1.2, 1.1.3, 1.1.5, 1.3.2, 1.3.4 and 1.3.7 are observed. The relevant technical documentation described in Annex VII, part B has been compiled.

Products we supply must not be put into service until the final machinery into which it is to be incorporated has been declared in conformity with the provisions of the Machinery Directive 2006/42/EC.

Operators are obliged to install the products observing the accepted industry codes and practices (good engineering practice) as well as the mounting and operating instructions. Operators must take appropriate precautions to prevent hazards that could be caused by the process medium and operating pressure in the valve as well as by the signal pressure and moving parts.

The permissible limits of application and mounting instructions for the products are specified in the associated mounting and operating instructions; the documents are available in electronic form on the Internet at www.samsongroup.com.

For product descriptions refer to:

- Type 42-34 and Type 42-38 Differential Pressure Regulators with Flow Limitation: Mounting and Operating Instructions EB 3013
- Type 42-36 Flow Regulator: Mounting and Operating Instructions EB 3015
- Type 42-36 E Pressure-independent Control Valve (PICV): Mounting and Operating Instructions EB 3018
- Type 42-37 Flow and Differential Pressure Regulator as well as Type 42-39 Flow and Differential Pressure or Pressure Regulator: Mounting and Operating Instructions EB 3017

Referenced technical standards and/or specifications:

- VCI, VDMA, VGB: "Leitfaden Maschinenrichtlinie (2006/42/EG) – Bedeutung für Armaturen, Mai 2018" [German only]
- VCI, VDMA, VGB: "Zusatzdokument zum Leitfaden Maschinenrichtlinie (2006/42/EG) – Bedeutung für Armaturen vom Mai 2018" [German only], based on DIN EN ISO 12100:2011-03

Comments:

- See mounting and operating instructions for residual hazards.
- Also observe the referenced documents listed in the mounting and operating instructions.

Persons authorized to compile the technical file:

SAMSON AG, Weismüllerstraße 3, 60314 Frankfurt am Main, Germany
Frankfurt am Main, 10 November 2021

Stephan Giesen
Director
Product Management

Peter Scheermesser
Director
Product Life Cycle Management and ETO
Development for Valves and Actuators

Revision no. 00

Classification: Public · SAMSON AKTIENGESELLSCHAFT · Weismüllerstraße 3 · 60314 Frankfurt, Germany

Page 1 of 1

DECLARATION OF INCORPORATION
TRANSLATION



Declaration of Incorporation in Compliance with Machinery Directive 2006/42/EC

For the following product:
Type 2424 Actuators

We certify that the Type 2424 Actuator is partly completed machine as defined in the Machinery Directive 2006/42/EC and that the safety requirements stipulated in Annex I, 1.1.2, 1.1.3, 1.1.5, 1.3.2, 1.3.4 and 1.3.7 are observed. The relevant technical documentation described in Annex VII, part B has been compiled.

Products we supply must not be put into service until the final machinery into which it is to be incorporated has been declared in conformity with the provisions of the Machinery Directive 2006/42/EC.

Operators are obliged to install the products observing the accepted industry codes and practices (good engineering practice) as well as the mounting and operating instructions. Operators must take appropriate precautions to prevent hazards that could be caused by the process medium and operating pressure in the valve as well as by the signal pressure and moving parts.

The permissible limits of application and mounting instructions for the products are specified in the associated data sheets as well as the mounting and operating instructions; the documents are available in electronic form on the Internet at www.samsongroup.com.

For product descriptions refer to:

- Type 42-24 Differential Pressure Regulator: Mounting and Operating Instructions EB 3003
- Type 2422/2424 Pressure Reducing Valve: Mounting and Operating Instructions EB 2549
- Type 42-34 Differential Pressure Limiter with Flow Limitation: Mounting and Operating Instructions EB 3013

Referenced technical standards and/or specifications:

- VCI, VDMA, VGB: "Leitfaden Maschinenrichtlinie (2006/42/EG) – Bedeutung für Armaturen, Mai 2018" [German only]
- VCI, VDMA, VGB: "Zusatzdokument zum Leitfaden Maschinenrichtlinie (2006/42/EG) – Bedeutung für Armaturen vom Mai 2018" [German only], based on DIN EN ISO 12100:2011-03

Comments:

- See mounting and operating instructions for residual hazards.
- Also observe the referenced documents listed in the mounting and operating instructions.

Persons authorized to compile the technical file:

SAMSON AG, Weismüllerstraße 3, 60314 Frankfurt am Main, Germany
Frankfurt am Main, 20 September 2021

Stephan Giesen
Director
Product Management

Peter Scheermesser
Director
Product Life Cycle Management and ETO Development for
Valves and Actuators

Revision no. 00

DECLARATION OF INCORPORATION
TRANSLATION



Declaration of Incorporation in Compliance with Machinery Directive 2006/42/EC

For the following product:

Type 2428 Actuators

We certify that the Type 2428 Actuator is partly completed machine as defined in the Machinery Directive 2006/42/EC and that the safety requirements stipulated in Annex I, 1.1.2, 1.1.3, 1.1.5, 1.3.2, 1.3.4 and 1.3.7 are observed. The relevant technical documentation described in Annex VII, part B has been compiled.

Products we supply must not be put into service until the final machinery into which it is to be incorporated has been declared in conformity with the provisions of the Machinery Directive 2006/42/EC.

Operators are obliged to install the products observing the accepted industry codes and practices (good engineering practice) as well as the mounting and operating instructions. Operators must take appropriate precautions to prevent hazards that could be caused by the process medium and operating pressure in the valve as well as by the signal pressure and moving parts.

The permissible limits of application and mounting instructions for the products are specified in the associated data sheets as well as the mounting and operating instructions; the documents are available in electronic form on the Internet at www.samsongroup.com.

For product descriptions refer to:

- Type 42-28 Differential Pressure Regulator: Mounting and Operating Instructions EB 3003
- Type 42-38 Differential Pressure Limiter with Flow Limitation: Mounting and Operating Instructions EB 3013

Referenced technical standards and/or specifications:

- VCI, VDMA, VGB: "Leitfaden Maschinenrichtlinie (2006/42/EG) – Bedeutung für Armaturen, Mai 2018" [German only]
- VCI, VDMA, VGB: "Zusatzdokument zum Leitfaden Maschinenrichtlinie (2006/42/EG) – Bedeutung für Armaturen vom Mai 2018" [German only], based on DIN EN ISO 12100:2011-03

Comments:

- See mounting and operating instructions for residual hazards.
- Also observe the referenced documents listed in the mounting and operating instructions.

Persons authorized to compile the technical file:

SAMSON AG, Weismüllerstraße 3, 60314 Frankfurt am Main, Germany
Frankfurt am Main, 7 February 2022

Stephan Giesen
Director
Product Management

Peter Scheermesser
Director
Product Life Cycle Management and ETO
Development for Valves and Actuators

Revision no. 00

Classification: Public · SAMSON AKTIENGESELLSCHAFT · Weismüllerstraße 3 · 60314 Frankfurt, Germany

Page 1 of 1



The Pressure Equipment (Safety) Regulations 2016
Module H / N° CE-0062-PED-H-SAM 001-22-DEU

For the following products, SAMSON hereby declares under its sole responsibility:

Devices	Type	Version
Self-operated Regulators	2423	DIN EN, body, EN-GJL-250, DN 150-250, PN 16, fluids G2, L2, L1 ¹⁾
		DIN EN, body, EN-GJS-400-18-LT, DN 150, PN 16, fluids G2, L2, L1 ¹⁾
		DIN EN, body, EN-GJS-400-18-LT, DN 100-150, PN 25, fluids G2, L2, L1 ¹⁾
		DIN EN, body, 1.0619 and 1.4408, DN 65-250, PN 16, all fluids
		DIN EN, body, 1.0619 and 1.4408, DN 50-250, PN 25, all fluids
		DIN EN, body, 1.0619 and 1.4408, DN 32-250, PN 40, all fluids
		ANSI, body, A126 B, NPS 6-10, Class 125, fluids G2, L2, L1 ¹⁾
		ANSI, body, A216 WCC and A351 CF8M, NPS 2½-10, Class 150, all fluids
		ANSI, body, A216 WCC and A351 CF8M, NPS 1½-10, Class 300, all fluids

¹⁾ Gases according to Article 4(1)(c.i), second indent // Liquids according to Article 4(1)(c.ii) acc. to PE(S)R 2016

The object of the declaration described above is in conformity with the relevant Union harmonization legislation:

Legislation: STATUTORY INSTRUMENTS – 2016 No. 1105 – CONSUMER PROTECTION HEALTH AND SAFETY – The Pressure Equipment (Safety) Regulations 2016	PE(S)R 2016	2022
Applied conformity assessment procedure for fluids according to Article 4(1)	Module H	Certificate-No.: N°CE-0062-PED-H-SAM 001-22-DEU by Bureau Veritas 0062

The manufacturer's quality management system is monitored by the following approved body:
Bureau Veritas Services SAS, 8 Cours du Triangle, 92800 PUTEAUX – LA DEFENSE (No. 0062)
Designated Standards applied: EN 12516-2, EN 12516-3;
Other technical standards applied: ASME B16.34

Manufacturer:
SAMSON AKTIENGESELLSCHAFT, Weismüllerstraße 3, 60314 Frankfurt am Main, Germany
Frankfurt am Main, 8th November 2022

ppc. Norbert Tollas

Norbert Tollas
Senior Vice President
Global Operations

i. v. P. Peter Scheermesser

Peter Scheermesser
Director
Product Maintenance & Engineered Products

UK UK DECLARATION OF CONFORMITY
CA ORIGINAL



**The Pressure Equipment (Safety) Regulations 2016
 Module A**

For the following products, SAMSON hereby declares under its sole responsibility:

Devices	Type	Version
Self-operated Regulators	2423	DIN EN, body, EN-GJL-250 and EN-GJS-400-18-LT, DN 65-125, PN 16, fluids G2, L2, L1 ¹⁾
		DIN EN, body, EN-GJS-418-LT, DN 50-80, PN 25, fluids G2, L2, L1 ¹⁾
		DIN EN, body, 1.0619 and 1.4408, DN 32-50, PN 16, all fluids
		DIN EN, body, 1.0619 and 1.4408, DN 32-40, PN 25, all fluids
		ANSI, body, A126 B, NPS 3-4, Class 125, fluids G2, L2, L1 ¹⁾
		ANSI, body, A216 WCC and A351 CF8M, NPS 1½-2, Class 150, all fluids

¹⁾ Gases according to Article 4(1)(c.i), second indent // Liquids according to Article 4(1)(c.ii) acc. to PE(S)R 2016

The object of the declaration described above is in conformity with the relevant Union harmonization legislation:

Legislation: STATUTORY INSTRUMENTS – 2016 No. 1105 – CONSUMER PROTECTION HEALTH AND SAFETY – The Pressure Equipment (Safety) Regulations 2016	PE(S)R 2016
Applied conformity assessment procedure for fluids according to Article 4(1)	Module A

Technical standards applied: EN 12516-2, EN 12516-3;
 Other technical standards applied: ASME B16.34

Manufacturer:
SAMSON AKTIENGESELLSCHAFT, Weismüllerstraße 3, 60314 Frankfurt am Main, Germany
 Frankfurt am Main, 8th November 2022

Norbert Tollas
 Senior Vice President
 Global Operations

Peter Scheermesser
 Director
 Product Maintenance & Engineered Products



UK DECLARATION OF CONFORMITY
ORIGINAL



Declaration of Conformity of Final Machinery

in accordance with Schedule 2 Part 2 Annex II, section 1.A. of the Directive 2008 No. 1597 The Supply of Machinery (Safety) Regulations 2008

For the following product:

Type 42-34 Differential Pressure Regulator with Flow Limitation consisting of Type 2423 Valve and Type 2424 Actuator

We hereby declare that the machinery mentioned above complies with all applicable requirements stipulated in Directive 2008 No. 1597 The Supply of Machinery (Safety) Regulations 2008.

For product descriptions refer to:

- Type 42-34 and Type 42-38 Differential Pressure Regulators with Flow Limitation: Mounting and Operating Instructions EB 3013

Referenced technical standards and/or specifications:

- VCI, VDMA, VGB: "Leitfaden Maschinenrichtlinie (2006/42/EG) – Bedeutung für Armaturen, Mai 2018" [German only]
- VCI, VDMA, VGB: "Zusatzdokument zum „Leitfaden Maschinenrichtlinie (2006/42/EG) – Bedeutung für Armaturen vom Mai 2018" [German only], based on DIN EN ISO 12100:2011-03

Comment:

Information on residual risks of the machinery can be found in the mounting and operating instructions of the valve and actuator as well as in the referenced documents listed in the mounting and operating instructions.

Persons authorized to compile the technical file:

SAMSON AG, Weismüllerstraße 3, 60314 Frankfurt am Main, Germany
Frankfurt am Main, 27 April 2022

Norbert Tollas
Senior Vice President
Global Operations

Peter Scheermesser
Director
Product Maintenance & Engineered Products

Revision 00

UK UK DECLARATION OF CONFORMITY
CA ORIGINAL



Declaration of Conformity of Final Machinery

in accordance with Schedule 2 Part 2 Annex II, section 1.A. of the Directive 2008 No. 1597 The Supply of Machinery (Safety) Regulations 2008

For the following product:

Type 42-38 Differential Pressure Regulator with Flow Limitation consisting of Type 2423 Valve and Type 2428 Actuator

We hereby declare that the machinery mentioned above complies with all applicable requirements stipulated in Directive 2008 No. 1597 The Supply of Machinery (Safety) Regulations 2008.

For product descriptions refer to:

- Type 42-34 and Type 42-38 Differential Pressure Regulators with Flow Limitation: Mounting and Operating Instructions EB 3013

Referenced technical standards and/or specifications:

- VCI, VDMA, VGB: "Leitfaden Maschinenrichtlinie (2006/42/EG) – Bedeutung für Armaturen, Mai 2018" [German only]
- VCI, VDMA, VGB: "Zusatzdokument zum „Leitfaden Maschinenrichtlinie (2006/42/EG) – Bedeutung für Armaturen vom Mai 2018" [German only], based on DIN EN ISO 12100:2011-03

Comment:

Information on residual risks of the machinery can be found in the mounting and operating instructions of the valve and actuator as well as in the referenced documents listed in the mounting and operating instructions.

Persons authorized to compile the technical file:

SAMSON AG, Weismüllerstraße 3, 60314 Frankfurt am Main, Germany
Frankfurt am Main, 27 April 2022

Norbert Tollas
Senior Vice President
Global Operations

Peter Scheermesser
Director
Product Maintenance & Engineered Products

Revision 00

Classification: Public · SAMSON AKTIENGESELLSCHAFT · Weismuellerstrasse 3 · 60314 Frankfurt am Main, Germany

Page 1 of 1



UK DECLARATION OF INCORPORATION
ORIGINAL



Declaration of Incorporation of Partly Completed Machinery

in accordance with Schedule 2 Part 2 Annex II, section 1.B. of the Directive 2008 No. 1597 Supply of Machinery (Safety) Regulations 2008

For the following product:

Type 2423 Valve

We certify that the Type 2423 Valve is partly completed machinery as defined in the in Directive 2008 No. 1597 Supply of Machinery (Safety) Regulations 2008 and that the safety requirements stipulated in Annex I, 1.1.2, 1.1.3, 1.1.5, 1.3.2, 1.3.4 and 1.3.7 are observed. The relevant technical documentation described in Annex VII, (Part 7 of Schedule 2) part B has been compiled.

Products we supply must not be put into service until the final machinery into which it is to be incorporated has been declared in conformity with the provisions of the Directive 2008 No. 1597 Supply of Machinery (Safety) Regulations 2008.

Operators are obliged to install the products observing the accepted industry codes and practices (good engineering practice) as well as the mounting and operating instructions. Operators must take appropriate precautions to prevent hazards that could be caused by the process medium and operating pressure in the valve as well as by the signal pressure and moving parts.

The permissible limits of application and mounting instructions for the products are specified in the associated mounting and operating instructions; the documents are available in electronic form on the Internet at www.samsongroup.com.

For product descriptions refer to:

- Type 42-34 and Type 42-38 Differential Pressure Regulators with Flow Limitation: Mounting and Operating Instructions EB 3013
- Type 42-36 Flow Regulator: Mounting and Operating Instructions EB 3015
- Type 42-36 E Pressure-independent Control Valve (PICV): Mounting and Operating Instructions EB 3018
- Type 42-37 Flow and Differential Pressure Regulator as well as Type 42-39 Flow and Differential Pressure or Pressure Regulator: Mounting and Operating Instructions EB 3017

Referenced technical standards and/or specifications:

- VCI, VDMA, VGB: "Leitfaden Maschinenrichtlinie (2006/42/EG) – Bedeutung für Armaturen, Mai 2018" [German only]
- VCI, VDMA, VGB: "Zusatzdokument zum Leitfaden Maschinenrichtlinie (2006/42/EG) – Bedeutung für Armaturen vom Mai 2018" [German only], based on DIN EN ISO 12100:2011-03

Comments:

- See mounting and operating instructions for residual hazards.
- Also observe the referenced documents listed in the mounting and operating instructions.

Persons authorized to compile the technical file:

SAMSON AG, Weismüllerstraße 3, 60314 Frankfurt am Main, Germany
Frankfurt am Main, 27 April 2022

Stephan Giesen
Director
Product Management

Peter Scheermesser
Director
Product Maintenance & Engineered Products

Revision 00

UK UK DECLARATION OF INCORPORATION
CA ORIGINAL



Declaration of Incorporation of Partly Completed Machinery

in accordance with Schedule 2 Part 2 Annex II, section 1.B. of the Directive 2008 No. 1597 Supply of Machinery (Safety) Regulations 2008

For the following product:

Type 2424 Actuator

We certify that the Type 2424 Actuator is partly completed machinery as defined in the in Directive 2008 No. 1597 Supply of Machinery (Safety) Regulations 2008 and that the safety requirements stipulated in Annex I, 1.1.2, 1.1.3, 1.1.5, 1.3.2, 1.3.4 and 1.3.7 are observed. The relevant technical documentation described in Annex VII, (Part 7 of Schedule 2) part B has been compiled.

Products we supply must not be put into service until the final machinery into which it is to be incorporated has been declared in conformity with the provisions of the Directive 2008 No. 1597 Supply of Machinery (Safety) Regulations 2008.

Operators are obliged to install the products observing the accepted industry codes and practices (good engineering practice) as well as the mounting and operating instructions. Operators must take appropriate precautions to prevent hazards that could be caused by the process medium and operating pressure in the valve as well as by the signal pressure and moving parts.

The permissible limits of application and mounting instructions for the products are specified in the associated mounting and operating instructions; the documents are available in electronic form on the Internet at www.samsongroup.com.

For product descriptions refer to:

- Type 42-24 Differential Pressure Regulator: Mounting and Operating Instructions EB 3003
- Type 2422/2424 Pressure Reducing Valve: Mounting and Operating Instructions EB 2547
- Type 42-34 Differential Pressure Limiter with Flow Limitation: Mounting and Operating Instructions EB 3013

Referenced technical standards and/or specifications:

- VCI, VDMA, VGB: "Leitfaden Maschinenrichtlinie (2006/42/EG) – Bedeutung für Armaturen, Mai 2018" [German only]
- VCI, VDMA, VGB: "Zusatzdokument zum Leitfaden Maschinenrichtlinie (2006/42/EG) – Bedeutung für Armaturen vom Mai 2018" [German only], based on DIN EN ISO 12100:2011-03

Comments:

- See mounting and operating instructions for residual hazards.
- Also observe the referenced documents listed in the mounting and operating instructions.

Persons authorized to compile the technical file:

SAMSON AG, Weismüllerstraße 3, 60314 Frankfurt am Main, Germany
Frankfurt am Main, 22 December 2022

Stephan Giesen
Director
Product Management

Peter Scheermesser
Director
Product Maintenance & Engineered Products



UK DECLARATION OF INCORPORATION
ORIGINAL



Declaration of Incorporation of Partly Completed Machinery

in accordance with Schedule 2 Part 2 Annex II, section 1.B. of the Directive 2008 No. 1597 Supply of Machinery (Safety) Regulations 2008

For the following product:

Type 2428 Actuator

We certify that the Type 2428 Actuator is partly completed machinery as defined in the in Directive 2008 No. 1597 Supply of Machinery (Safety) Regulations 2008 and that the safety requirements stipulated in Annex I, 1.1.2, 1.1.3, 1.1.5, 1.3.2, 1.3.4 and 1.3.7 are observed. The relevant technical documentation described in Annex VII, (Part 7 of Schedule 2) part B has been compiled.

Products we supply must not be put into service until the final machinery into which it is to be incorporated has been declared in conformity with the provisions of the Directive 2008 No. 1597 Supply of Machinery (Safety) Regulations 2008.

Operators are obliged to install the products observing the accepted industry codes and practices (good engineering practice) as well as the mounting and operating instructions. Operators must take appropriate precautions to prevent hazards that could be caused by the process medium and operating pressure in the valve as well as by the signal pressure and moving parts.

The permissible limits of application and mounting instructions for the products are specified in the associated mounting and operating instructions; the documents are available in electronic form on the Internet at www.samsongroup.com.

For product descriptions refer to:

- Type 42-28 Differential Pressure Regulator: Mounting and Operating Instructions EB 3003
- Type 42-38 Differential Pressure Limiter with Flow Limitation: Mounting and Operating Instructions EB 3013

Referenced technical standards and/or specifications:

- VCI, VDMA, VGB: "Leitfaden Maschinenrichtlinie (2006/42/EG) – Bedeutung für Armaturen, Mai 2018" [German only]
- VCI, VDMA, VGB: "Zusatzdokument zum Leitfaden Maschinenrichtlinie (2006/42/EG) – Bedeutung für Armaturen vom Mai 2018" [German only], based on DIN EN ISO 12100:2011-03

Comments:

- See mounting and operating instructions for residual hazards.
- Also observe the referenced documents listed in the mounting and operating instructions.

Persons authorized to compile the technical file:

SAMSON AG, Weismüllerstraße 3, 60314 Frankfurt am Main, Germany
Frankfurt am Main, 27 April 2022

Stephan Giesen
Director
Product Management

Peter Scheermesser
Director
Product Maintenance & Engineered Products

Revision 00

15 Annex

15.1 Tightening torques

Table 15-1: *Tightening torque*

Component	Width across flats	Valve size/ actuator area	Tightening torque in Nm
Connecting piece (10)	SW 36	All	150
Coupling nuts (11)			120
Nuts and bolts (15)	–	80 cm ²	20
		160 cm ² , 320 cm ² , 640 cm ² ¹⁾	25
		640 cm ² ²⁾	40
Set point adjuster (17)	SW 27	160 to 640 cm ²	–
Nut (18)	SW 12	160 to 640 cm ²	40
Control line connection (20)	–	160 to 640 cm ²	22
Stopper (22)	Width across flats 13 mm (G ¼ thread)	–	50
	Width across flats 17 mm (G ¾ thread)		70

15.2 Lubricants

SAMSON's After-sales Service can support you concerning lubricants and sealants approved by SAMSON.

15.3 Tools

SAMSON's After-sales Service can support you concerning tools approved by SAMSON.

15.4 Accessories

Needle valves and compression-type screw fittings can be supplied as required. These accessories are listed in ► T 3095.

15.5 Spare parts

Legend for Fig. 15-1 and Fig. 15-2

2	Bellows	24	Compression spring	52	Hex nut
5	Restriction	26	Guide tube	81	Cap
12	Screw	27	Bottom section	82	Hex nut
16	Seat	34	Flange	132	O-ring
17	Plug	35	Screw plug	171	Clamping ring
20	Body	46	Graphite seal on metal core	172	Seal
21	Guide cap	51	Stud		
22	Label				

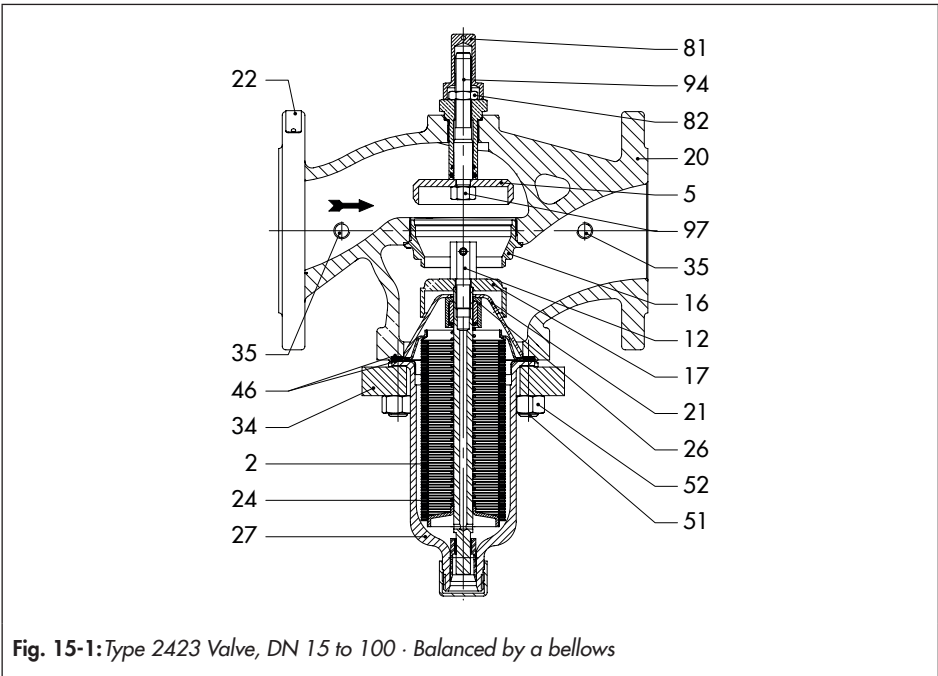

Fig. 15-1: Type 2423 Valve, DN 15 to 100 · Balanced by a bellows

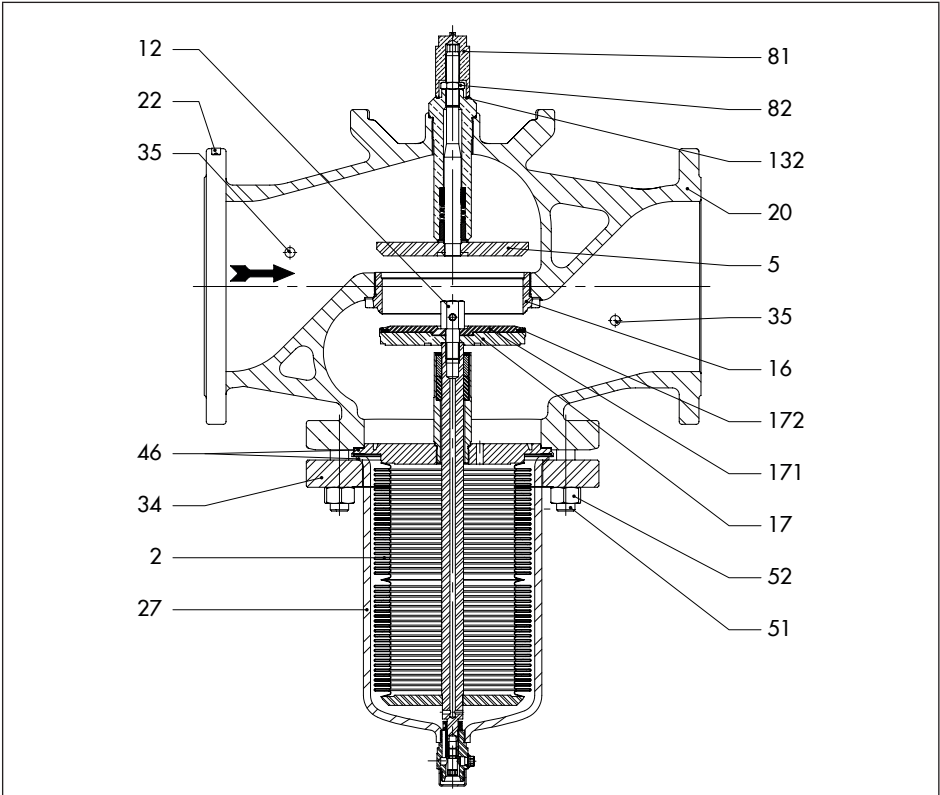

Fig. 15-2: Type 2423 Valve, DN 125 to 250 · Balanced by a bellows

Legend for Fig. 15-3

5	Restriction	18	Plug	51	Stud
8	Compression spring	19	Screw	52	Hex nut
10	Diaphragm plate	20	Body	53	Screw plug
11	Diaphragm	21	Guide cap	81	Nut
12	Castle nut	22	Label	82	Hex nut
13	Washer	27	Bonnet	94	Stem
14	Plug stem	34	Ring	97	Hex nut (self-locking)
16	Seat	46	Seal		

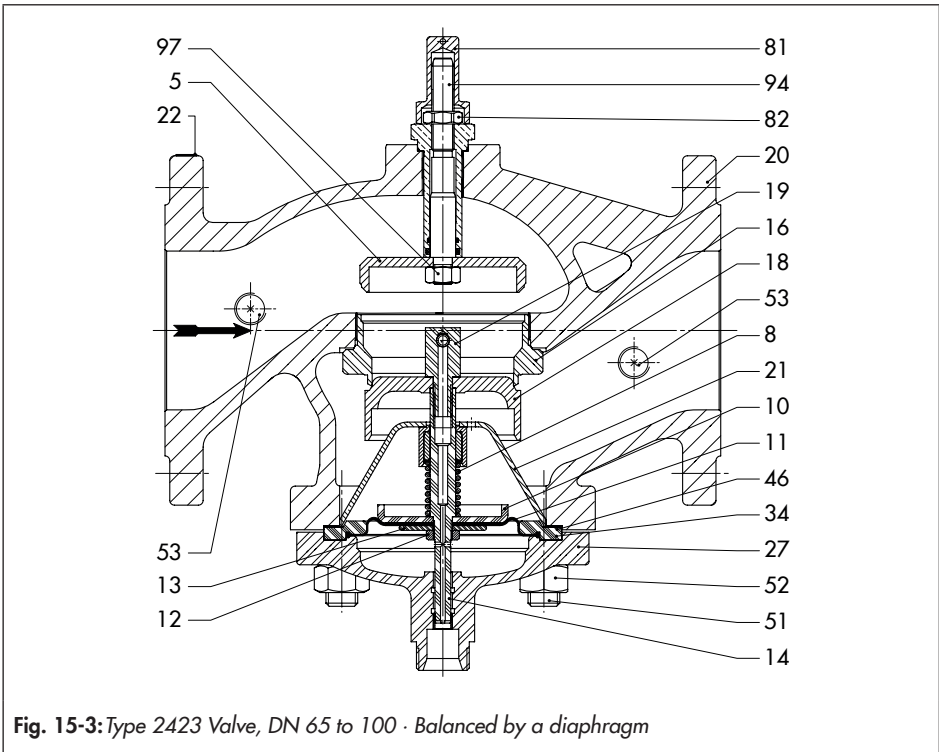

Fig. 15-3: Type 2423 Valve, DN 65 to 100 · Balanced by a diaphragm

Legend for Fig. 15-4

2	Restriction	21	Nipple	49	Screw plug
5	Seat	24	Nut	50	Screw plug
6	Diaphragm case	38	Diaphragm plate	51	Stud
11	Cap	39	Diaphragm plate	52	Hex nut
12	Body	42	Clamping disk	53	Hex nut
17	Label	46	Seal	54	Hex nut
19	Plug	47	Diaphragm	57	O-ring

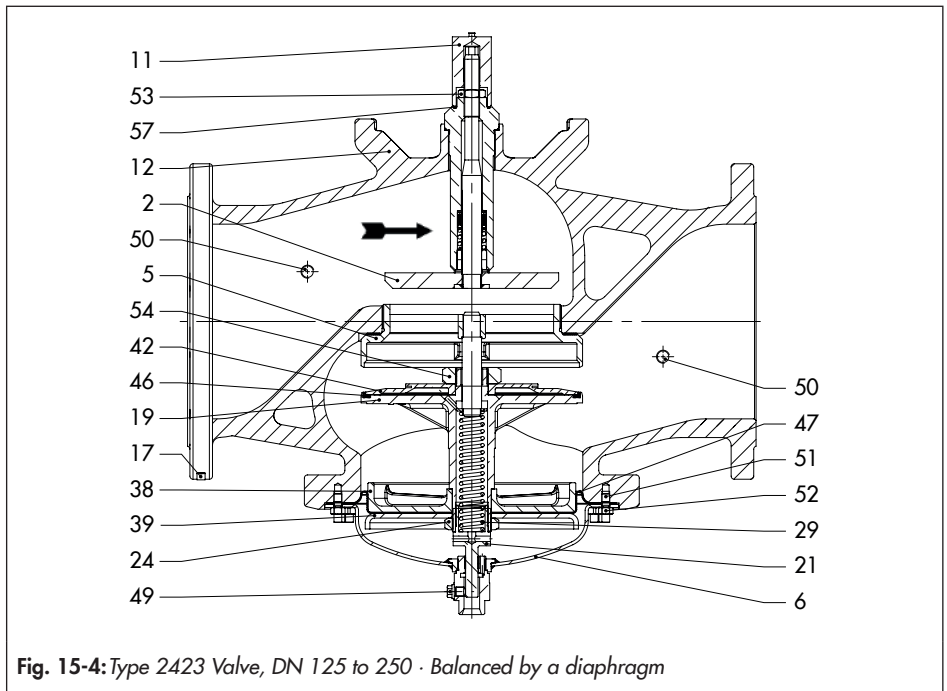
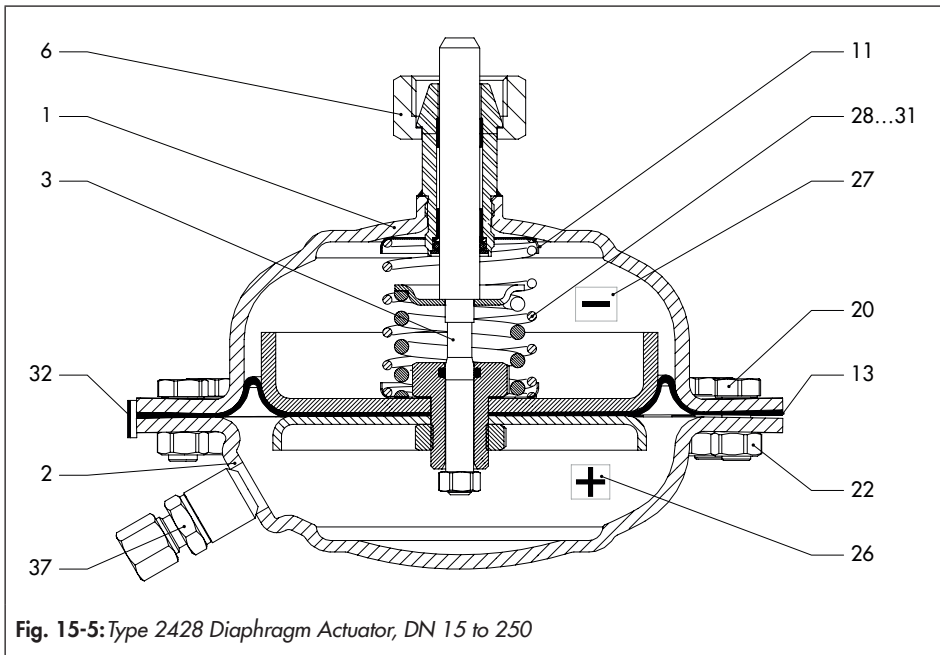

Fig. 15-4: Type 2423 Valve, DN 125 to 250 · Balanced by a diaphragm

Legend for Fig. 15-5

1	Diaphragm case assembly	20	Bolt
2	Diaphragm case assembly	22	Nut
3	Diaphragm stem with excess pressure limiter and diaphragm	26	Adhesive label +
6	Coupling nut	27	Adhesive label -
11	Spring plate	28...31	Compression spring
13	Diaphragm	32	Nameplate
		37	Screw joint with restriction



Legend for Fig. 15-6

1	Diaphragm case assembly	20	Adhesive label +
2	Diaphragm case assembly	21	Adhesive label -
4	Nipple	22	Nameplate
5	Guide nipple	25	Nut of set point adjuster
7	Diaphragm stem with excess pressure limiter and diaphragm	27...29	Set point springs
8	Force limiter	30	Compression spring
11	Coupling nut	36	Spring plate
17	Bolt	46	Axial needle bearing
18	Nut	49	Cap
		51	Washer

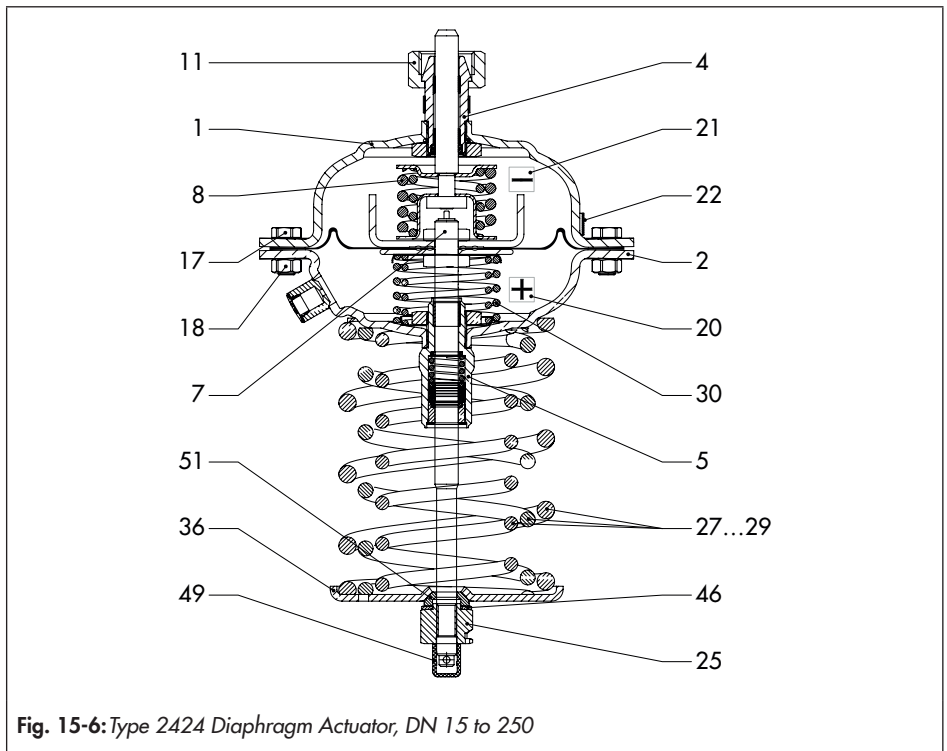

Fig. 15-6: Type 2424 Diaphragm Actuator, DN 15 to 250

15.6 After-sales service

Contact SAMSON's After-sales Service for support concerning service or repair work or when malfunctions or defects arise.

E-mail address

You can reach our after-sales service at aftersalesservice@samsongroup.com.

Addresses of SAMSON AG and its subsidiaries

The addresses of SAMSON, its subsidiaries, representatives and service facilities worldwide can be found on our website (▶ www.samsongroup.com) or in all SAMSON product catalogs.

Required specifications

Please submit the following details:

- Device type and valve size
- Valve balanced by a bellows or diaphragm
- Model number or material number
- Upstream and downstream pressure
- Temperature and process medium
- Min. and max. flow rate in m³/h
- Is a strainer installed?
- Installation drawing showing the exact location of the regulator and all the additionally installed components (shut-off valves, pressure gauge etc.)



SAMSON AKTIENGESELLSCHAFT
Weismüllerstraße 3 · 60314 Frankfurt am Main, Germany
Phone: +49 69 4009-0 · Fax: +49 69 4009-1507
samson@samsongroup.com · www.samsongroup.com