

Note on these mounting and operating instructions

These mounting and operating instructions assist you in mounting and operating the device safely. The instructions are binding for handling SAMSON devices. The images shown in these instructions are for illustration purposes only. The actual product may vary.

- For the safe and proper use of these instructions, read them carefully and keep them for later reference.
- If you have any questions about these instructions, contact SAMSON's After-sales Service (aftersaleservice@samsongroup.com).



Documents relating to the device, such as the mounting and operating instructions, are available on our website at www.samsongroup.com > **Downloads > Documentation.**

Definition of signal words

DANGER

Hazardous situations which, if not avoided, will result in death or serious injury

WARNING

Hazardous situations which, if not avoided, could result in death or serious injury

NOTICE

Property damage message or malfunction

Note

Additional information

Tip

Recommended action

| | | |
|----------|---|-----------|
| 1 | Safety instructions and measures | 5 |
| 1.1 | Notes on possible severe personal injury | 8 |
| 1.2 | Notes on possible personal injury | 8 |
| 1.3 | Notes on possible property damage | 9 |
| 2 | Markings on the device | 11 |
| 2.1 | Nameplate | 11 |
| 2.2 | Location of the nameplate | 11 |
| 2.3 | Material identification number | 11 |
| 3 | Design and principle of operation | 12 |
| 3.1 | Technical data | 14 |
| 4 | Measures for preparation | 18 |
| 4.1 | Unpacking | 18 |
| 4.2 | Transporting and lifting | 18 |
| 4.3 | Storage | 18 |
| 5 | Mounting and start-up | 20 |
| 5.1 | Mounting positions | 20 |
| 5.2 | Additional fittings | 21 |
| 5.3 | Preparation for installation | 22 |
| 5.3.1 | Cleaning the pipeline | 22 |
| 5.4 | Installation | 23 |
| 5.4.1 | Installing the regulator | 23 |
| 5.4.2 | Filling the plant | 23 |
| 5.5 | Testing the regulator | 24 |
| 5.5.1 | Leakage | 24 |
| 5.5.2 | Pressure test | 25 |
| 5.6 | Insulation | 25 |
| 6 | Start-up | 26 |
| 6.1 | Start-up and putting the device back into operation | 27 |
| 6.2 | Starting up the plant | 27 |
| 7 | Operation | 27 |
| 7.1 | Adjusting the set point | 27 |
| 8 | Servicing | 28 |
| 8.1 | Cleaning and replacing the seat and plug | 29 |
| 8.2 | Exchanging the operating diaphragm | 31 |
| 8.3 | Replacing the set point springs | 32 |
| 8.4 | Tightening torques and lubricant | 34 |

Contents

| | | |
|-----------|---|-----------|
| 8.5 | Preparation for return shipment..... | 35 |
| 8.6 | Ordering spare parts and operating supplies | 35 |
| 9 | Malfunctions | 38 |
| 10 | Decommissioning and removal | 38 |
| 10.1 | Decommissioning..... | 39 |
| 10.2 | Disposal..... | 39 |
| 11 | Appendix..... | 40 |
| 11.1 | After-sales service..... | 40 |
| 11.2 | Spare parts | 40 |
| 12 | Certificates..... | 43 |

1 Safety instructions and measures

Intended use

The SAMSON Type 44-2, Type 44-3 and Type 44-9 Pressure Regulators are suitable for pressure control of liquids and gases. The regulators are designed to operate under exactly defined conditions (e.g. operating pressure, process medium, temperature). Therefore, operators must ensure that the regulators are only used in operating conditions that meet the specifications used for sizing the devices at the ordering stage. In case operators intend to use the regulators in applications or conditions other than those specified, contact SAMSON. SAMSON does not assume any liability for damage resulting from the failure to use the device for its intended purpose or for damage caused by external forces or any other external factors.

➔ Refer to the technical data and nameplate for limits and fields of application as well as possible uses.

Reasonably foreseeable misuse

The regulators are not suitable for the following applications:

- Use outside the limits defined during sizing and by the technical data
- Use outside the limits defined by the accessories mounted on the regulator

Furthermore, the following activities do not comply with the intended use:

- Use of non-original spare parts
- Performing service and repair work not described
- Modification of parts as well as service or repair work on TÜV-tested Type 44-3 and Type 44-9

Revisions and other modifications

Revisions, conversions or other modifications of the product are not authorized by SAMSON. They are performed at the user's own risk and may lead to safety hazards, for example. Furthermore, the product may no longer meet the requirements for its intended use.

Qualifications of operating personnel

The regulator must be mounted, started up, serviced and repaired by fully trained and qualified personnel only; the accepted industry codes and practices must be observed. According to these mounting and operating instructions, trained personnel refers to individuals who are able to judge the work they are assigned to and recognize possible hazards due to their specialized training, their knowledge and experience as well as their knowledge of the applicable standards.

Safety instructions and measures

Personal protective equipment

SAMSON recommends checking the hazards posed by the process medium being used (e.g.

▶ GESTIS (CLP) hazardous substances database).

- Protective clothing, safety gloves and eye protection in applications with hot, cold and/or corrosive media
 - Wear hearing protection when working near the valve. Follow the instructions given by the plant operator.
 - Safety harness, e.g. when working at height
 - Safety footwear, if applicable ESD (electrostatic discharge) footwear
- ➔ Check with the plant operator for details on further protective equipment.

Warning against residual hazards

To avoid personal injury or property damage, plant operators and operating personnel must prevent hazards that could be caused in the regulator by the process medium, the operating pressure, the signal pressure or by moving parts by taking appropriate precautions. Plant operators and operating personnel must observe all hazard statements, warnings and caution notes in these mounting and operating instructions, especially for installation, start-up and service work.

SAMSON also recommends checking the hazards posed by the process medium being used (e.g. ▶ GESTIS (CLP) hazardous substances database).

➔ Observe safety measures for handling the device as well as fire prevention and explosion protection measures.

Responsibilities of the operator

Operators are responsible for proper use and compliance with the safety regulations.

Operators are obliged to provide these mounting and operating instructions as well as the referenced documents to the operating personnel and to instruct them in proper operation.

Furthermore, operators must ensure that operating personnel or third parties are not exposed to any danger.

Operators are additionally responsible for ensuring that the limits for the product defined in the technical data are observed. This also applies to the start-up and shutdown procedures. Start-up and shutdown procedures fall within the scope of the operator's duties and, as such, are not part of these mounting and operating instructions. SAMSON is unable to make any statements about these procedures since the operative details (e.g. differential pressures and temperatures) vary in each individual case and are only known to the operator.

Responsibilities of operating personnel

Operating personnel must read and understand these mounting and operating instructions as well as the referenced documents and observe the specified hazard statements, warnings and caution notes. Furthermore, operating personnel must be familiar with the applicable health, safety and accident prevention regulations and comply with them.

Safety features

The Type 44-2 Regulator does not have any special safety features.

The Type 44-3 and Type 44-9 Regulators are safety shut-off valves (SSV) with integrated pressure reducing valve.

Thanks to the backup diaphragm, the Type 44-3 Regulator can continue to function after the operating diaphragm fails.

Upon failure of the operating diaphragm, the Type 44-9 Regulator is completely closed.

When relieved of pressure, the regulators are opened by the force of the set point springs.

Referenced standards, directives and regulations

The regulators comply with the requirements of the European Pressure Equipment Directive 2014/68/EU. Regulators with a CE marking have an EU declaration of conformity, which includes information about the applied conformity assessment procedure. This EU declaration of conformity is included in the Appendix of these instructions (see Chapter 12).

According to the ignition hazard assessment performed in accordance with Clause 5.2 of ISO 80079-36, the non-electrical regulators do not have their own potential ignition source even in the rare incident of an operating fault. As a result, they do not fall within the scope of Directive 2014/34/EU.

➔ For connection to the equipotential bonding system, observe the requirements specified in Clause 6.4 of EN 60079-14 (VDE 0165-1).

Referenced documents

The following documents apply in addition to these mounting and operating instructions:

- Mounting and operating instructions for
 - e.g. **Type 1 NI Strainer** ▶ EB 1010
 - e.g. **Type 2 NI Strainer** ▶ EB 1015
- Mounting and operating instructions as well as data sheets for additional fittings (e.g. shut-off valves, pressure gauges etc.).

1.1 Notes on possible severe personal injury

DANGER

Risk of bursting in pressure equipment.

Regulators and pipelines are pressure equipment. Improper opening can lead to regulator components bursting.

- If necessary, a suitable overpressure protection must be installed on site in the plant section.
- Before starting any work on the regulator, depressurize all plant sections affected.
- Drain the process medium from the plant sections affected as well as from the regulator.
- Wear personal protective equipment.

1.2 Notes on possible personal injury

WARNING

Risk of personal injury due to preloaded springs.

Regulators in combination with preloaded set point springs are under tension. These regulators can be identified by the red warning label on the actuator's set point springs.

- Before starting any work on the springs, relieve the compression from the preloaded springs.
- Only use the SAMSON disassembly tool (1 280-4052).

Risk of personal injury due to residual process medium in the regulator.

While working on the regulator, residual process medium can escape and, depending on its properties, may lead to personal injury, e.g. (chemical) burns.

- If possible, drain the process medium from the plant sections affected and from the regulator.
- Wear protective clothing, safety gloves and eye protection.

⚠ WARNING**Risk of burn injuries due to hot or cold components and pipelines.**

Depending on the process medium, regulator components and pipelines may get very hot or cold and cause burn injuries.

- Allow components and pipelines to cool down or warm up to the ambient temperature.
- Wear protective clothing and safety gloves.

Crush hazard arising from moving parts.

The regulator contains moving parts (actuator and plug stem), which can injure hands or fingers if inserted into the valve.

- Do not insert hands or fingers between the set point springs while the regulator is in operation.
- Before performing any work on the regulator, depressurize the plant. Disconnect or shut off the external control line.

Damage to health relating to the REACH regulation.

If a SAMSON device contains a substance listed as a substance of very high concern on the candidate list of the REACH regulation, this is indicated on the SAMSON delivery note.

- Information on the safe use of the part affected ► www.samsongroup.com/en/about-samson/environment-social-governance/material-compliance/.

1.3 Notes on possible property damage

ⓘ NOTICE**Risk of regulator damage due to contamination (e.g. solid particles) in the pipeline.**

The plant operator is responsible for cleaning the pipelines in the plant.

- Flush the pipelines before start-up.
- Observe the maximum permissible pressure for regulator and plant.

! NOTICE

Risk of regulator damage due to unsuitable medium properties.

The regulator is designed for a process medium with defined properties.

→ Only use the process medium specified for sizing the equipment.

Risk of regulator damage due to the use of unsuitable tools.

Certain tools are required to work on the regulator.

→ Only use tools approved by SAMSON.

Risk of regulator damage due to the use of unsuitable lubricants.

The lubricants to be used depend on the regulator material. Unsuitable lubricants may corrode and damage surfaces.

→ Only use lubricants approved by SAMSON.

Risk of regulator damage due to the installation of solenoid valves.

If solenoid valves are installed downstream of the regulator when the regulator is used to control liquids, pressure peaks may occur when the solenoid valves close quickly. These pressure peaks can damage the regulator.

→ The installation of solenoid valves downstream of the regulator is not permitted when the regulator is used to control liquids.

Risk of leakage and regulator damage due to over- or under-torquing.

Observe the specified torques when tightening regulator components. Excessive tightening torques lead to parts wearing out more quickly. Parts that are too loose may cause leakage.

→ Observe the specified tightening torques.

i Note

SAMSON's After-sales Service can support you concerning lubricant, tightening torques and tools approved by SAMSON.

2 Markings on the device

2.1 Nameplate

| | | |
|---|----|---|
| 1 | 2 | 3 |
| 4 | | 5 |
| 6 | 10 | 7 |
| 8 | | 9 |

- 1 Model number
- 2 Material number and device index
- 3 Order number or year of manufacture
- 4 Type designation
- 5 Pressure rating PN
- 6 K_{VS} (C_v) coefficient
- 7 Perm. temperature in °C
- 8 Set point range in bar
- 9 Max. perm. differential pressure Δp in bar
- 10 Arrow indicating the direction of flow

Fig. 1: *Nameplate*

2.2 Location of the nameplate

The nameplate of all sizes is affixed to the body (see Fig. 2).

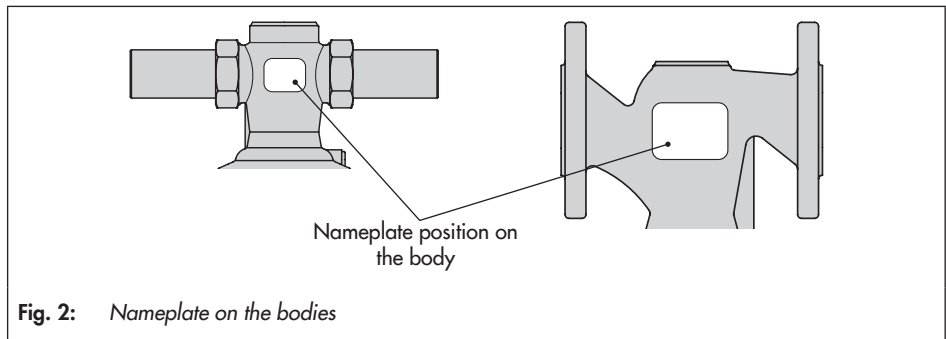

2.3 Material identification number

Specifying the material number, you can contact SAMSON to find out which material is used. It is specified on the nameplate (2, Mat-No. and device index). For more details on the nameplate, see Chapter 2.1.

3 Design and principle of operation

→ See Fig. 3

The regulators are open when relieved of pressure.

They close when the downstream pressure rises above the adjusted set point.

The **Type 44-2, Type 44-3 and Type 44-9** Pressure Reducing Valves mainly consist of the valve body (30) with seat (35) and plug (2) as well as the actuator with operating diaphragm (125), set point springs (70...78) and set point adjuster (56).

The pressure reducing valve is used to maintain the pressure downstream of the valve to an adjusted set point.

The process medium flows through the regulator between seat and plug in the direction indicated by the arrow on the body. The position of the valve plug determines the flow rate and, as a result, the downstream pressure.

The downstream pressure p_2 to be controlled is transmitted over the control line (116) to the operating diaphragm (125) where it is converted into a positioning force. This force is used to move the valve plug according to the force of the set point springs (70...78). The spring force is adjustable at the set point adjuster (56).

The **Type 44-3 Safety Shut-off Valve (SSV) with integrated pressure reducing valve** is equipped with a second backup diaphragm. Upon failure of the first operating diaphragm (125) the **regulator continues to function using the backup diaphragm (126)**. In this case, the regulator functions as a safety shut-off valve (SSV) with integrated pressure reducing valve when the downstream pressure rises too far and closes the valve. Diaphragm failure is indicated by a red mark in the diaphragm rupture indicator (12) (point of response at approx. 1.5 bar) or medium escapes at the test connection.

The **Type 44-9 Safety Shut-off Valve (SSV) with integrated pressure reducing valve** is equipped with a second backup diaphragm (126). Upon failure of the first operating diaphragm (125) the **regulator is completely closed**. Diaphragm failure is indicated by a red mark in the diaphragm rupture indicator (12) (point of response at approx. 1.5 bar) or medium escapes at the test connection.

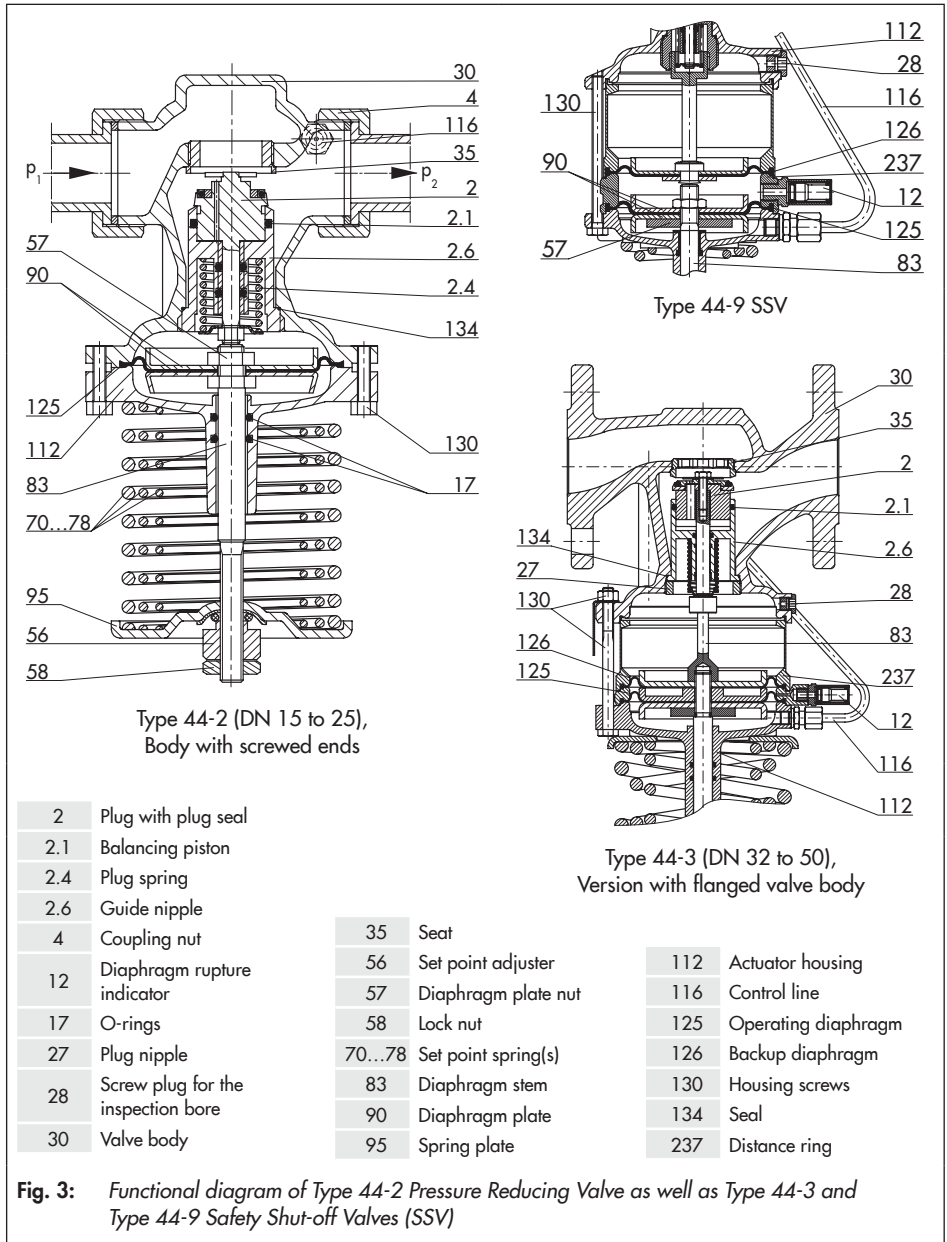

3.1 Technical data

The nameplate on the regulator contains information on the regulator version (see Chapter 2.1).

Process medium and scope of application

The pressure reducing valves and safety shut-off valves (SSV) with integrated pressure reducing valve are designed to maintain the pressure downstream of the regulator to the adjusted set point in district heating systems or large heating networks.

Type 44-2, Type 44-3 and Type 44-9 are suitable for **controlling liquids and gases**.

- Max. permissible temperatures for gases up to **80 °C**
- Air/nitrogen up to **150 °C**¹⁾
- Liquids up to **150 °C**

The regulator is open when relieved of pressure. It closes when the downstream pressure rises above the adjusted set point.

Type test

The Type 44-3 and Type 44-9 Regulators are shut-off valves (SSV) with integrated pressure reducing valve and are typetested by TÜV.

The test mark is available on request.

¹⁾ With seals made of FKM

Temperature range

The Type 44-2, Type 44-3 and Type 44-9 Regulators are designed for a temperature range from 0 to +150 °C.

Leakage class

All regulators have the leakage class I according to IEC 60534-4.

Noise emissions

SAMSON is unable to make general statements about noise emissions. The noise emissions depend on the regulator version, plant facilities and process medium. On request, SAMSON can perform calculations according to IEC 60534, Part 8-3 and Part 8-4 or VDMA 24422 (edition 89).

WARNING

Risk of hearing loss or deafness due to loud noise.

- *Wear hearing protection when working near the valve. Follow the instructions given by the plant operator.*
-

Dimensions and weights

Table 4 provides a summary of the dimensions and weights of the Type 44-2, Type 44-3 and Type 44-9 Regulators. The lengths and heights in the dimensional drawings are shown on page 17 onwards.

Table 1: *Technical data · All pressures in bar (gauge)*

| Regulator | | Pressure reducing valve | |
|---|--------------------------------|--|-------------------------|
| | | 44-2 | 44-3 (SSV) · 44-9 (SSV) |
| Port | Red brass body | Male thread DN 15, 20, 25, 32, 40 and 50 | |
| | Spheroidal graphite iron body | Flanges DN 32, 40 and 50 | |
| Pressure rating | | PN 25 | |
| Max. permissible temperature | Liquids | 150 °C | |
| | Non-flammable gases | 80 °C | |
| | Air and nitrogen ¹⁾ | 150 °C | |
| Set point range (continuously adjustable) | | 1 to 4 bar ³⁾ · 2 to 4.2 bar 2.4 to 6.3 bar · 6 to 10.5 bar | |
| Leakage class according to IEC 60534-4 | | ≤0.05 % of K _{VS} coefficient ²⁾ | |
| Max. permissible pressure at diaphragm actuator | | 1 bar above the closing point adjusted at the valve ⁴⁾ | |
| Conformity | | CE EAC | |
| Max. perm. ambient temperature | | 60 °C | |

¹⁾ With seals made of FKM; without type test (Types 44-3 and 44-9)

²⁾ Leakage rate = 1/bubble-tight applies to EPDM/FKM soft seal.

³⁾ Special version of Type 44-3 and Type 44-9, without type test

⁴⁾ To be protected by a downstream (safety) excess pressure valve.

Table 2: *Materials · Material numbers according to DIN EN*

| Body | Red brass CC499K | Spheroidal graphite iron EN-GJS-400-18-LT |
|--|---|---|
| Seat | 1.4305 | |
| Plug ²⁾ | Brass 2.0402 and stainless steel 1.4305 with EPDM soft seal ¹⁾ | |
| Actuator housing/ intermediate ring | Red brass CC499K | |
| Set point spring | 1.4310 | |
| Operating diaphragm | EPDM with fabric reinforcement ¹⁾ | |
| Seals | EPDM ¹⁾ | |

¹⁾ Special version, e.g. for mineral oils: FKM

²⁾ K_{VS} 0.4: stainless steel 1.4305

Design and principle of operation

Table 3: K_{VS} coefficients · X_{FZ} values · Max. permissible differential pressure Δp

| Nominal size | DN | 15 | 20 | 25 | 32 | 40 | 50 |
|---|------------------|-------------------------------|-----|---------------------------------------|------|--------|------|
| Max. perm. differential pressure Δp | | 20 bar | | | | 12 bar | |
| x_{Fz} values | | 0.60 | | 0.55 | | 0.5 | 0.45 |
| Body with screwed ends | | | | | | | |
| K_{VS} coefficients | Standard version | 2.5 | 6.3 | 8.0 | 12.5 | 16.0 | 20.0 |
| | Special version | 0.4 ¹⁾ · 1.0 · 4.0 | | 1.0 ²⁾ · 2.5 ²⁾ | | – | |
| Flanged body | | | | | | | |
| K_{VS} coefficients | Standard version | – | | | 12.5 | 20.0 | 25.0 |

1) Special version of Type 44-2

2) Special version of Type 44-9

Table 4: Dimensions · Weights

| Nominal size | DN | 15 | 20 | 25 | 32 | 40 | 50 |
|--|--------------|-------|-------------------|---------|---------|---------|---------|
| Length L | mm | 65 | 70 | 75 | 100 | 110 | 130 |
| Pipe $\varnothing d$ | mm | 21.3 | 26.9 | 33.7 | 42.4 | 48.3 | 60.3 |
| Connection R | | G 3/4 | G 1 | G 1 1/4 | G 1 3/4 | G 2 | G 2 1/2 |
| Width across flats (A/F) | mm | 30 | 36 | 46 | 59 | 65 | 82 |
| Height H | Type 44-2 | mm | 230 | | 250 | 380 | |
| | Type 44-3 | mm | 285 ¹⁾ | | 443 | | |
| | Type 44-9 | mm | 317 ²⁾ | | 475 | 488 | |
| Height H1 | mm | 34 | | 43 | | 45 | |
| Actuator housing $\varnothing D$ | mm | 116 | | | | 160 | |
| Version with welding ends | | | | | | | |
| Length L1 | mm | 210 | 234 | 244 | 268 | 294 | 330 |
| Weight | kg (approx.) | 2.0 | 2.1 | 2.2 | 8.5 | 9.0 | 9.5 |
| Version with threaded ends | | | | | | | |
| Length L2 | mm | 129 | 144 | 159 | 192 | 206 | 228 |
| Male thread A | | G 1/2 | G 3/4 | G 1 | G 1 1/4 | G 1 1/2 | G 2 |
| Weight | kg (approx.) | 2.0 | 2.1 | 2.2 | 8.5 | 9.0 | 9.5 |
| Version with screwed-on flanges or with flanged body (DN 32 to 50 only) | | | | | | | |
| Length L3 | mm | – | | | 180 | 200 | 230 |
| Weight | kg (approx.) | – | | | 11.7 | 13.0 | 14.5 |

¹⁾ 310 mm with 6 to 10.5 bar set point range

²⁾ 355 mm with 6 to 10.5 bar set point range

Dimensional drawings

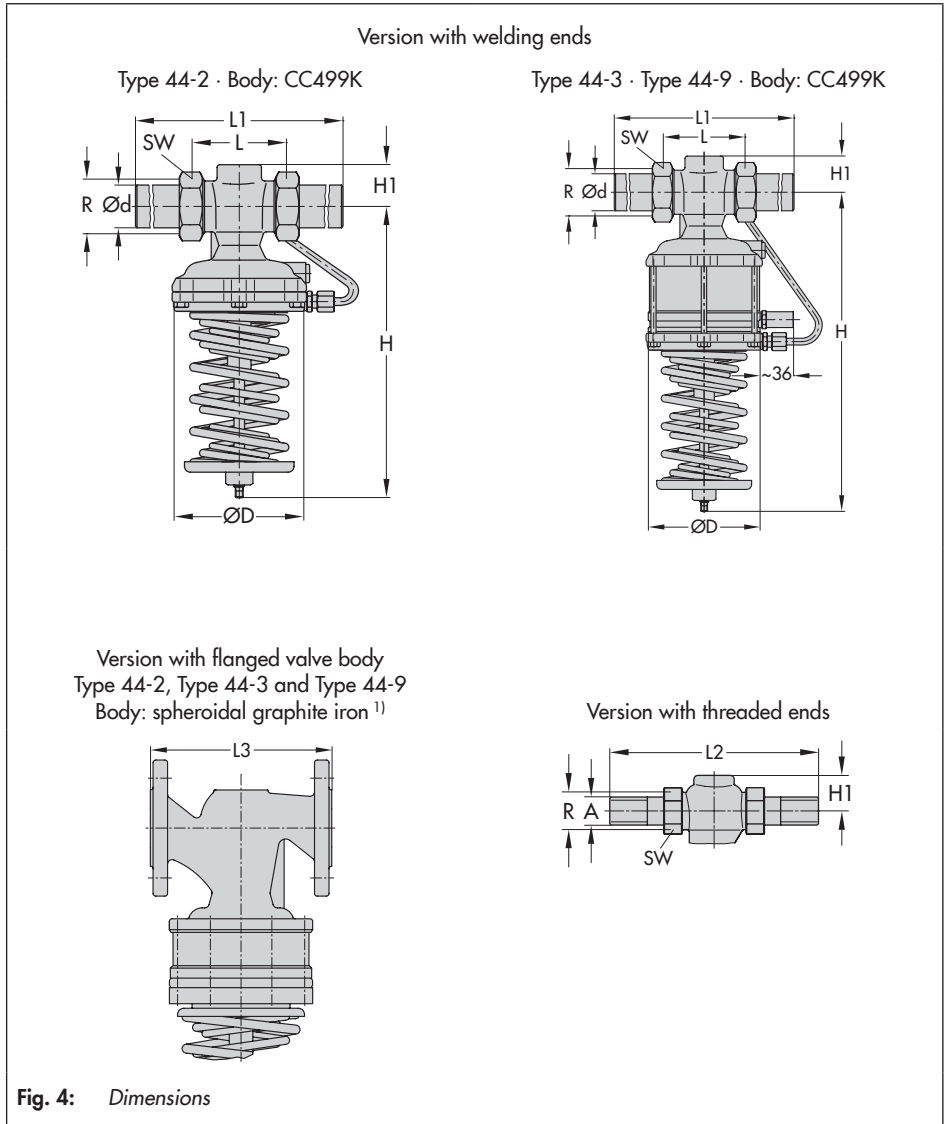

¹⁾ DN 32, 40 and 50

4 Measures for preparation

After receiving the shipment, proceed as follows:

1. Check the scope of delivery. Compare the shipment received with the delivery note.
2. Check the shipment for transportation damage. Report any damage to SAMSON and the forwarding agent (refer to delivery note).

4.1 Unpacking

i Note

Do not remove the packaging until immediately before installing the valve into the pipeline.

4.2 Transporting and lifting

Due to the low service weight, lifting equipment is not required to lift and transport the regulator (e.g. to install it into the pipeline).

Transport instructions

- Protect the device against external influences (e.g. impact).
- Do not damage the corrosion protection (paint, surface coatings). Repair any damage immediately.
- Protect the device against moisture and dirt.
- Observe the permissible ambient temperatures (see Chapter 3.1).

4.3 Storage

! NOTICE

Risk of regulator damage due to improper storage.

- *Observe the storage instructions.*
- *Avoid longer storage periods.*
- *Contact SAMSON in case of different storage conditions or longer storage times.*

i Note

SAMSON recommends to regularly check the device and the prevailing storage conditions during long storage periods.

Storage instructions

- Protect the device against external influences (e.g. impact).
- Do not damage the corrosion protection (paint, surface coatings). Repair any damage immediately.
- Protect the device against moisture and dirt. Store it at a relative humidity of less than 75 %. In damp spaces, prevent condensation. If necessary, use a drying agent or heating.
- Make sure that the ambient air is free of acids or other corrosive media.
- Observe the permissible ambient temperatures (see Chapter 3.1).
- Do not place any objects on the device.

Special storage instructions for elastomers

Elastomer, e.g. operating diaphragm

- To keep elastomers in shape and to prevent cracking, do not bend them or hang them up.
- SAMSON recommends a storage temperature of 15 °C for elastomers.
- Store elastomers away from lubricants, chemicals, solutions and fuels.



Tip

Our after-sales service can provide more detailed storage instructions on request.

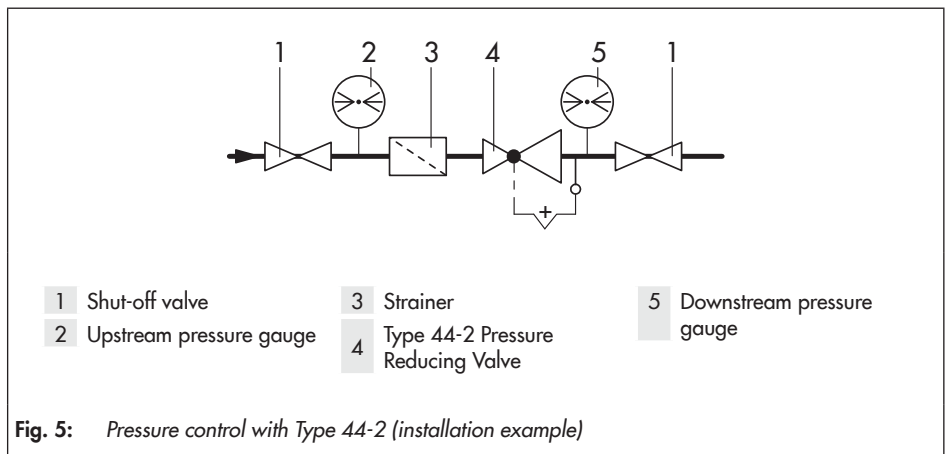

5 Mounting and start-up

NOTICE

Risk of overheating due to excessive ambient temperatures or insufficient heat dissipation when components are insulated.

– Do not include the regulator in the insulation of the pipeline.

NOTICE

Risk of impaired functioning of the regulator and leakage at the joint due to installation under tension.

– Bolt the regulator to the pipeline free of stress.

– If necessary, support the pipelines near the connections.

– Do not attach supports directly to the regulator.

5.1 Mounting positions

Install **Type 44-2**, **Type 44-3** and **Type 44-9** with the actuator housing suspended downward in horizontal pipelines.

Installation conditions

- Make sure that the regulator remains freely accessible after the plant has been completed.
- Install a strainer upstream of the regulator (see Chapter 5.2).
- Make sure the direction of flow matches the direction indicated by the arrow on the body.
- Install the regulator free of stress.
- The valves are connected to the pipeline using threaded ends, welding ends or flanged body.
- See schematic drawings of typical installations (Fig. 5 and Fig. 6).

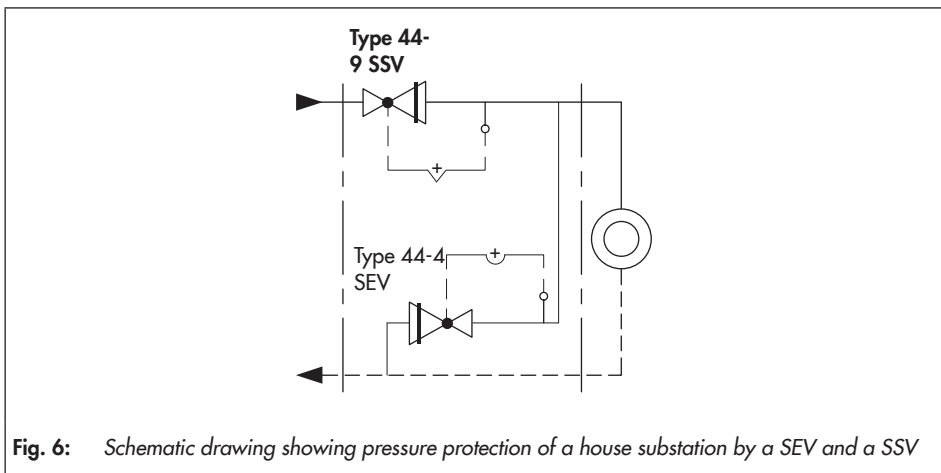

Fig. 6: Schematic drawing showing pressure protection of a house substation by a SEV and a SSV

NOTICE

Possible malfunction and damage due to adverse weather conditions (temperature, humidity).

- Do not install the device outdoors or in rooms prone to frost.
- Protect the regulator against frost if it is used to control freezing media.
- Either heat the regulator or remove it from the plant and completely drain the residual medium after a plant shutdown.

- Allow sufficient space to remove the filter.
- Observe the flow direction through the strainer.
- In horizontal pipelines with gases or liquids, the filter element faces downward. The filter element faces sideways in applications with steam.
- Install strainers in vertical pipelines with the medium flowing upward with the drain plug facing upward.

5.2 Additional fittings

NOTICE

Damage due to pressure peaks.

If solenoid valves are installed downstream of the regulator when the regulator is used to control liquids, pressure peaks may occur when the solenoid valves close quickly. The installation of solenoid valves is not permitted when the regulator is used to control liquids.

Note

Check the strainer at regular intervals and clean it, if necessary.

Strainer

A strainer installed upstream in the flow pipe holds back any dirt or other foreign particles carried along by the medium. For example, the SAMSON Type 1 NI Strainer is suitable (► T 1010).

The following points must be observed when installing the strainer:

Shut-off valve

Install a hand-operated shut-off valve both upstream of the strainer and downstream of the regulator (see Fig. 5). This allows the plant to be shut down for cleaning and maintenance, and when the plant is not used for longer periods of time.

Pressure gauges

Install a pressure gauge both upstream and downstream of the regulator to monitor the pressures prevailing in the plant (see Fig. 5).

5.3 Preparation for installation

Before mounting, make sure the following conditions are met:

- The regulator is clean.
- The regulator is not damaged.
- Install a strainer upstream of the regulator.
- The regulator data on the nameplate (type designation, nominal size, material, pressure rating and temperature range) match the plant conditions (nominal size and pressure rating of the pipeline, medium temperature etc.). See the 'Markings on the device' chapter for nameplate details.
- The requested or required additional fittings (see the 'Design and principle of operation' chapter) have been installed or prepared as necessary before installing the valve.

Proceed as follows:

- Lay out the necessary material and tools to have them ready during installation work.
- Flush the pipeline **before** installing the regulator (see Chapter 5.3.1). The plant operator is responsible for cleaning the pipelines in the plant.
- Check any mounted pressure gauges to make sure they function properly.

5.3.1 Cleaning the pipeline

SAMSON recommends additionally flushing the pipeline without an installed regulator over a time period of several minutes before start-up. In this case, install a suitable length of pipe into the pipeline in place of the regulator.

- Before flushing the plant with the process medium, read the information under 'Starting up the plant' in Chapter 6.
- Observe the mesh size of the upstream strainer for the maximum particle size. Use strainers to suit the process medium.
- Check the strainer for dirt each time the pipeline is flushed and clean it, if necessary.

5.4 Installation

SAMSON regulators are delivered as assembled units. The activities listed below are necessary for installation and before start-up of the regulator.

i Note

SAMSON's After-sales Service can support you concerning lubricant, tightening torques and tools approved by SAMSON.

! NOTICE

Risk of regulator damage due to over- or under-torquing.

Observe the specified torques when tightening regulator components. Excessive tightening torques lead to parts wearing out more quickly. Parts that are too loose may cause leakage.

→ *Observe the specified tightening torques (see Chapter 8.4).*

5.4.1 Installing the regulator

1. Close the shut-off valves upstream and downstream of the regulator while the regulator is being installed.
2. Remove the protective caps from the valve ports of regulators with flanges before installation.
3. Observe the flow direction through the valve. The arrow on the valve indicates the direction of flow.
4. Make sure that the correct gaskets are used.
5. Bolt the pipe to the valve free of stress.
6. Slowly open the shut-off valves in the pipeline after the regulator has been installed.

5.4.2 Filling the plant

Open the shut-off valves slowly over a time period of several minutes preferably starting from the upstream pressure side to fill the plant (all consumers are open).

- Make sure that the pressure rises simultaneously upstream and downstream of the regulator to avoid damaging it.
- Avoid pressure surges.

5.5 Testing the regulator

⚠ DANGER

Risk of bursting due to incorrect opening of pressurized equipment or components.

Regulators and pipelines are pressure equipment that may burst when handled incorrectly. Flying projectile fragments or the release of process medium under pressure can cause serious injury or even death.

Before working on the regulator:

- Depressurize all plant sections concerned and the regulator.
- Disconnect the control line.
- Drain the process medium from the plant sections affected as well as from the valve.

⚠ DANGER

Risk of personal injury due to process medium escaping.

- Do not start up the regulator until all parts have been mounted.

⚠ WARNING

Risk of hearing loss or deafness due to loud noise.

Noise emission (e.g. cavitation or flashing) may occur during operation caused by the process medium and the operating conditions.

- Wear hearing protection when working near the valve. Follow the instructions given by the plant operator.

⚠ WARNING

Risk of burn injuries due to hot or very cold components and pipelines.

Depending on the process medium, the regulator and pipelines may get very hot or cold and cause burn injuries.

- Wear protective clothing and safety gloves.

SAMSON regulators are delivered ready for use. To test the regulator functioning before start-up or putting back the regulator into operation, perform the following tests:

5.5.1 Leakage

The plant operator is responsible for performing the leak test and selecting the test method. The leak test must comply with the requirements of the national and international standards that apply at the site of installation.

💡 Tip

SAMSON's After-sales Service can support you to plan and perform a leak test for your plant.

1. Install the regulator into the pipeline (see Chapter 5.4.1).
2. Apply the required test pressure.
3. Check the regulator for leakage to the atmosphere.
4. Depressurize the pipeline section and regulator.
5. Rework any parts that leak and repeat the leak test.

5.5.2 Pressure test

i Note

The plant operator is responsible for performing the pressure test. SAMSON's After-sales Service can support you to plan and perform a pressure test for your plant.

! NOTICE

Risk of the operating diaphragm bursting due to excessive pressure during pressure testing.

- The pressure must not exceed the maximum permissible pressure by 1.5 times the pressure rating.
- Remove the control line from the regulator and seal the open connection with a blanking plug (accessories: blanking plug 8323-0030 and seal 8412-0771).

! NOTICE

Risk of regulator damage due to a sudden pressure increase and resulting high flow velocities.

- Slowly open the shut-off valves.

During the pressure test, make sure the following conditions are met:

- Do not allow the pressure to exceed the 1.5 times the pressure rating of the valve body.
- Remove the control line from the regulator and seal the open connection with a blanking plug (accessories: blanking plug 8323-0030 and seal 8412-0771).

- Make sure that the pressure rises simultaneously upstream and downstream of the regulator to avoid damaging it.

5.6 Insulation

To insulate cold systems, SAMSON recommends first filling the plant and carefully rinsing it. The regulator must not yet be insulated at this stage.

! NOTICE

Risk of regulator damage due to incorrect insulation.

- Only insulate the regulator up to the actuator housing for medium temperatures below 0 °C/32 °F or above 80 °C/175 °F.

1. Start up the plant and adjust the set point (see Chapter 6).
2. Shut down the plant again and let it heat up until the condensation water has dried off.
3. Insulate the regulator and pipes conveying the process medium using insulation material with a water vapor barrier. If an external control line is to be routed through the insulation, special care must be taken with the sealing since slight changes in shape may occur. The insulation thickness depends on the medium temperature and the ambient conditions. 50 mm is a typical thickness.

6 Start-up

The work described in this chapter is to be performed only by personnel appropriately qualified to carry out such tasks.

⚠ DANGER

Risk of personal injury due to process medium escaping.

– *Do not start up the regulator until all parts have been mounted.*

⚠ WARNING

Risk of burn injuries due to hot or cold components and pipeline.

Regulator components and the pipeline may become very hot or cold. Risk of burn injuries.

→ *Allow components and pipelines to cool down or warm up to the ambient temperature.*

→ *Wear protective clothing and safety gloves.*

⚠ WARNING

Risk of hearing loss or deafness due to loud noise.

Noise emission (e.g. cavitation or flashing) may occur during operation caused by the process medium and the operating conditions.

→ *Wear hearing protection when working near the valve. Follow the instructions given by the plant operator.*

⚠ WARNING

Risk of personal injury due to pressurized components and as a result of process medium being discharged.

→ *Do not unscrew the control line while the valve is pressurized.*

Before start-up or putting the valve back into service, make sure the following conditions are met:

- The regulator is properly installed in the pipeline (see Chapter 5).
- The leak and function tests have been completed successfully (see Chapter 5.5).
- The prevailing conditions in the plant section concerned meet the regulator sizing requirements (see section 'Intended use' in the 'Safety instructions and measures' chapter).

6.1 Start-up and putting the device back into operation

1. Depending on the field of application, allow the regulator to cool down or warm up to reach ambient temperature before start up.
2. All consumer valves are open.
3. Slowly open the shut-off valves in the pipeline. Slowly opening these valves prevents a sudden surge in pressure and high flow velocities which may damage the valve.
4. Check the regulator to ensure it functions properly (see section 'Adjusting the set point in the 'Operation' chapter).

6.2 Starting up the plant

1. The plant is filled with the process medium (see section 'Filling the plant' in the 'Installation' chapter).
 - To start up the pressure regulator, open shut-off valves **slowly**.
2. Slowly open the shut-off valves upstream of the pressure regulator.
3. Slowly open all the valves downstream of the regulator (consumer side).
4. Avoid pressure surges.
5. Put the pressure regulator into operation.

7 Operation

7.1 Adjusting the set point

→ See Fig. 3

Adjust the required set point by turning the set point adjuster (56) with an open-end wrench.

i Note

The following open-end wrench sizes are required to adjust the set point:

- 19 mm for DN 15 to 32
 - 27 mm for DN 40 and 50
-

Set point adjuster

- Undo the lock nut (58) (for 6 to 10.5 bar set point range only).
- Turn the set point screw clockwise (↻) to increase the pressure set point.
- Turn the set point screw counterclockwise (↺) to reduce the pressure set point.
- Tighten the lock nut (58) (for 6 to 10.5 bar set point range only).

The pressure gauge (Fig. 5) installed on the downstream side on site allows the adjusted set point to be monitored.

The set point range can be changed by exchanging the set point springs (70...78) (see Chapter 8.3).

8 Servicing

The regulator does not require much maintenance. Nevertheless, it is subject to natural wear, particularly at the seat, plug and operating diaphragm. Depending on the operating conditions, check the regulator at regular intervals to avoid possible malfunctions.

⚠ DANGER

Risk of bursting in pressure equipment.

Regulators and pipelines are pressure equipment. Improper opening can lead to bursting of the regulator.

- Before starting any work on the regulator, depressurize all plant sections affected as well as the regulator.
- Drain the process medium from the plant sections affected as well as from the regulator.
- Wear personal protective equipment.

⚠ WARNING

Risk of personal injury due to residual process medium in the regulator.

While working on the regulator, residual process medium can escape and, depending on its properties, may lead to personal injury, e.g. (chemical) burns.

Wear protective clothing, safety gloves and eye protection.

⚠ WARNING

Risk of burn injuries due to hot or cold components and pipeline.

Regulator components and the pipeline may become very hot or cold. Risk of burn injuries.

- Allow components and pipelines to cool down or warm up to the ambient temperature.
- Wear protective clothing and safety gloves.

ⓘ NOTICE

Risk of regulator damage due to incorrect servicing or repair.

Only allow trained staff to perform service and repair work.

ⓘ NOTICE

Risk of regulator damage due to over- or under-torquing.

Observe the specified torques when tightening regulator components. Excessive tightening torques lead to parts wearing out more quickly. Parts that are too loose may cause leakage.

Observe the specified tightening torques.

ⓘ NOTICE

Risk of regulator damage due to the use of unsuitable tools.

Only use tools approved by SAMSON.

ⓘ NOTICE

Risk of regulator damage due to the use of unsuitable lubricants.

Only use lubricants approved by SAMSON.

i Note

SAMSON's After-sales Service can support you concerning lubricant, tightening torques and tools approved by SAMSON.

i Note

The regulator was checked by SAMSON before delivery.

- Certain test results certified by SAMSON lose their validity when the regulator is opened. Such testing includes seat leakage and leak tests.
- The product warranty becomes void if service or repair work not described in these instructions is performed without prior agreement by SAMSON's After-sales Service.
- Only use original spare parts by SAMSON, which comply with the original specifications.

💡 Tip

SAMSON's After-sales Service can support you in drawing up an inspection and test plan for your plant.

8.1 Cleaning and replacing the seat and plug

⚠ DANGER

Risk of personal injury due to preloaded springs.

Regulators in combination with preloaded set point springs are under tension. These regulators can be identified by the red warning label on the actuator's set point springs.

- Before starting any work on the springs, relieve the compression from the preloaded springs.
- Only use the SAMSON disassembly tool (1280-4052).

ⓘ NOTICE

Risk of regulator damage due to over- or under-torquing.

Observe the specified torques when tightening regulator components. Excessive tightening torques lead to parts wearing out more quickly. Parts that are too loose may cause leakage.

Observe the specified tightening torques.

ⓘ NOTICE

Risk of damage to the facing of the seat and plug due to incorrect service or repair.

Always replace both the seat and plug.

NOTICE

Risk of TÜV approval (based on AGFW worksheet FW 504) for Types 44-3 and 44-9 becoming void.

Consult SAMSON's After-sales Service before you change parts or perform service or repair work on TÜV-tested Type 44-3 and Type 44-9 Regulators.

Note

SAMSON's After-sales Service can support you concerning lubricant, tightening torques and tools approved by SAMSON.

Note

The socket wrench for DN 15 to 25 can also be made, for example from a GEDORE screwdriver bit (IN 19-19) by drilling a 17-mm-deep hole ($\varnothing 17$) into a 17 mm hex bit.

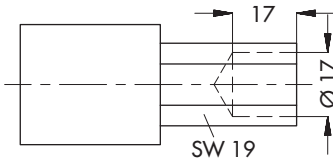

– SAMSON order no. 1280-3001

→ See Fig. 3

Disassembly of Type 44-2

1. Put the regulator out of operation (see Chapter 10.1).
2. Completely relieve the tension from the set point springs (70...78) by turning the set point adjuster (56) counterclockwise (\cup).
3. Remove the device from the pipeline.
4. Unscrew the control line (116).
5. Unscrew the body screws (130) and take off the actuator housing (112) together with the set point springs (70...78).
6. **DN 15 to 25:** unscrew and pull out the guide nipple (2.6) using a socket wrench.
DN 32 to 50: unscrew the plug nipple (27) and pull out the guide nipple (2.6).
7. Remove the seal (134).
8. Thoroughly clean the seat (35), plug (2) and balancing piston (2.1). Replace damaged parts with new ones.
9. Check the control line (116) for any blockages.
10. Unscrew the seat (35) using a seat wrench if the seat facing is damaged.

Assembly of Type 44-2

1. Screw in the seat (35) using a seat wrench. Observe the tightening torques specified in Chapter 8.4.
2. Renew the seal (134) and insert it into the body.

3. **DN 15 to 25:** insert and screw in the guide nipple (2.6). Observe the tightening torques specified in Chapter 8.4.
DN 32 to 50: insert the the guide nipple (2.6) and screw in the plug nipple (27). Observe the tightening torques specified in Chapter 8.4.
4. Check the facings of the actuator housing (112) for dirt and clean them, if necessary.
5. Place the actuator housing (112) on the valve body (30) and screw tight the body screws (130). Observe the tightening torques specified in Chapter 8.4.
6. Screw on the control line (116). Observe the tightening torques specified in Chapter 8.4.
7. Put the regulator into operation (see Chapter 6).

8.2 Exchanging the operating diaphragm

⚠ DANGER

Risk of personal injury due to preloaded springs.

Regulators in combination with preloaded set point springs are under tension. These regulators can be identified by the red warning label on the actuator's set point springs.

- Before starting any work on the springs, relieve the compression from the preloaded springs.
- Only use the SAMSON disassembly tool (1280-4052).

ⓘ NOTICE

Risk of regulator damage due to over- or under-torquing.

Observe the specified torques when tightening regulator components. Excessive tightening torques lead to parts wearing out more quickly. Parts that are too loose may cause leakage.

Observe the specified tightening torques.

ⓘ NOTICE

Risk of TÜV approval (based on AGFW worksheet FW 504) for Types 44-3 and 44-9 becoming void.

Consult SAMSON's After-sales Service before you change parts or perform service or repair work on TÜV-tested Type 44-3 and Type 44-9 Regulators.

ⓘ Note

SAMSON's After-sales Service can support you concerning lubricant, tightening torques and tools approved by SAMSON.

ⓘ Note

The stem surface is roller-burnished. Do not reface the stem.

After replacing the diaphragm stem, the nipple (guide bushing) in the actuator case must be replaced as well.



Tip

The associated order number is written on the actual rolling diaphragm.

➔ See Fig. 3

Disassembly of Type 44-2

1. Put the regulator out of operation (see Chapter 10.1).
 2. Completely relieve the tension from the set point springs (70...78) by turning the set point adjuster (56) counterclockwise (↺).
 3. Remove the device from the pipeline.
 4. Unscrew the control line (116).
 5. Use the SAMSON disassembly tool to unscrew the set point adjuster (56) from the diaphragm stem (83).
 6. Lift off the spring plate (95) and the set point springs (70...78).
 7. Unscrew the body screws (130) and take off the actuator housing (112).
 8. Unscrew the diaphragm plate nut (57) from the diaphragm stem (83).
 9. Take off the diaphragm plate (90) and operating diaphragm (125).
 10. Examine the diaphragm stem (83) for score marks. Replace, if necessary.
2. Apply lubricant to the diaphragm stem (83). See Chapter 8.4.
 3. Insert the diaphragm stem (83) together with the operating diaphragm (125) into the actuator housing (112).
 4. Check the facings of the actuator housing (112) for dirt and clean them, if necessary.
 5. Place the actuator housing (112) on the valve body (30) and tighten the screws (130) evenly. Observe tightening torque specified in Chapter 8.4.
 6. Use the SAMSON disassembly tool to screw the valve body (30) together with spring plate (95) and the set point springs (70...78).
 7. Screw the set point adjuster (56) onto the diaphragm stem (83).
 8. Screw on the control line (116). Observe tightening torque specified in Chapter 8.4.
 9. Put the regulator into operation (see Chapter 6).

Assembly of Type 44-2

1. Place the operating diaphragm (125) together with the diaphragm plate (90) onto the diaphragm stem (83) and tighten the nut (57). Observe the tightening torques specified in Chapter 8.4.

8.3 Replacing the set point springs

DANGER

Risk of personal injury due to preloaded springs.

Regulators in combination with preloaded set point springs are under tension. These regulators can be identified by the red warning label on the actuator's set point springs.

- Before starting any work on the springs, relieve the compression from the preloaded springs.
- Only use the SAMSON disassembly tool (1280-4052).

NOTICE

Risk of regulator damage due to over- or under-torquing.

Observe the specified torques when tightening regulator components. Excessive tightening torques lead to parts wearing out more quickly. Parts that are too loose may cause leakage.

Observe the specified tightening torques.

NOTICE

Risk of TÜV approval (based on AGFW worksheet FW 504) for Types 44-3 and 44-9 becoming void.

Consult SAMSON's After-sales Service before you change parts or perform service or repair work on TÜV-tested Type 44-3 and Type 44-9 Regulators.

Note

SAMSON's After-sales Service can support you concerning lubricant, tightening torques and tools approved by SAMSON.

See Fig. 3

Disassembly of Type 44-2

1. Put the regulator out of operation (see Chapter 10.1).
2. Completely relieve the tension from the set point springs (70...78) by turning the set point adjuster (56) counterclockwise (↺).
3. Remove the device from the pipeline.
4. Unscrew the control line (116).
5. Use the SAMSON disassembly tool to unscrew the set point adjuster (56) from the diaphragm stem (83).
6. Lift off the spring plate (95) and the set point springs (70...78).
7. Examine the diaphragm stem (83) for score marks. Replace, if necessary. Proceed as described in Chapter 8.2.

Assembly of Type 44-2

1. Use the SAMSON disassembly tool to screw the valve body (30) together with spring plate (95) and the set point springs (70...78).
2. Screw the set point adjuster (56) onto the diaphragm stem (83).
3. Screw on the control line (116). Observe tightening torque specified in Chapter 8.4.
4. Put the regulator into operation (see Chapter 6).

Note

Change the nameplate and material number after changing the set point range.

8.4 Tightening torques and lubricant

→ See Fig. 3

| Part | Nominal size | Tightening torque in Nm |
|-------------------------------|--------------|-------------------------|
| Guide nipple (2.6) | DN 15 to 25 | 70 |
| Coupling nut (4) | DN 15 | 80 |
| | DN 20 | 95 |
| | DN 25 | 110 |
| | DN 32 | 130 |
| | DN 40 | 160 |
| | DN 50 | 180 |
| Plug nipple (27) | DN 32 to 50 | 110 |
| Screw plug (28) | All | 5 |
| Seat (35) | DN 15 to 25 | 45 |
| | DN 32 to 50 | 110 |
| Diaphragm plate nut (57) | DN 15 to 25 | 40 |
| | DN 32 to 50 | 80 |
| Lock nut (58) | DN 15 to 32 | 4 |
| | DN 40 and 50 | 8 |
| Control line connection (116) | DN 15 to 50 | 22 |
| Body screws (130) | DN 15 to 32 | 8 |
| | DN 40 to 50 | 18 |

| Lubricant | Item no. |
|-------------|-----------|
| Gleitmo 591 | 8150-0111 |

8.5 Preparation for return shipment

Defective devices can be returned to SAMSON for repair. Proceed as follows to return devices to SAMSON:

1. Put the regulator out of operation (see Chapter 10.1).
2. Decontaminate the regulator. Remove any residual process medium.
3. Fill in the Declaration on Contamination. The declaration form can be downloaded from our website at
▶ www.samsongroup.com > Service > After-sales Service.
4. Continue as described on our website at
▶ www.samsongroup.com > Service > After-sales Service > Returning goods.

8.6 Ordering spare parts and operating supplies

Contact your nearest SAMSON subsidiary or SAMSON's After-sales Service for information on spare parts, lubricants and tools.

Spare parts

See Chapter 11.2 for details on spare parts.

Lubricants

Contact SAMSON's After-sales Service for more information on suitable lubricants.

Tools

Contact SAMSON's After-sales Service for more information on suitable tools.

Table 5: Troubleshooting

| Malfunction | Possible reasons | Recommended action |
|---|---|---|
| Downstream pressure drops below the adjusted set point. | Insufficient pressure pulses on the operating diaphragm. | <ul style="list-style-type: none"> → Connect the control line on site for regulators with external control line. → Clean the control line and screw fittings. → Draw up an energy balance. |
| | Pressure tapped at the wrong place (regulator with external control line). | <ul style="list-style-type: none"> → Reconnect the control line at another point. → Do not connect the control line at pipe bends or necks. |
| | Regulator installed against the flow. | <ul style="list-style-type: none"> → Install the regulator so that the direction of flow matches the direction indicated by the arrow on the body. |
| | Regulator or K_{VS}/C_V coefficient too small | <ul style="list-style-type: none"> → Check the sizing. → Change K_{VS}/C_V coefficient, if necessary or install a different sized regulator. |
| | Foreign particles blocking the plug | <ul style="list-style-type: none"> → Remove foreign particles. → Replace damaged parts. |
| | Safety device, e.g. pressure limiter, has been triggered | <ul style="list-style-type: none"> → Check plant. Unlock safety device. |
| | Strainer blocked. | <ul style="list-style-type: none"> → Clean the strainer. |
| Downstream pressure exceeds the adjusted set point. | Foreign particles blocking the plug | <ul style="list-style-type: none"> → Remove foreign particles. → Replace damaged parts. |
| | Seat and plug are worn or leak. | <ul style="list-style-type: none"> → Clean the seat and plug. → Replace the damaged seat and plug. |
| | Pressure tapped at the wrong place (regulator with external control line). | <ul style="list-style-type: none"> → Reconnect the control line at another point. → Do not connect the control line at pipe bends or necks. |
| | Seal the inspection borehole. | <ul style="list-style-type: none"> → Open the inspection borehole. |
| | Regulator or K_{VS}/C_V coefficient too large | <ul style="list-style-type: none"> → Check the sizing. → Change K_{VS}/C_V coefficient, if necessary or install a different sized regulator. |
| | Control line blocked | <ul style="list-style-type: none"> → Clean the control line and screw fittings. |
| | Defective operating diaphragm | <ul style="list-style-type: none"> → Replace damaged diaphragm. |
| Jerky control response | Increased friction, e.g. due to foreign particles between seat and plug or in the stem guide on the bonnet. | <ul style="list-style-type: none"> → Remove foreign particles. → Replace damaged parts. |

Table 5: Troubleshooting

| Malfunction | Possible reasons | Recommended action |
|--|--|--|
| Slow control response | Control line blocked by dirt causing the flow through it to be restricted. | → Clean the control line. |
| Downstream pressure hunts | Regulator too large | → Check the sizing. → Change K_{vs}/C_v coefficient, if necessary or install a different sized regulator. |
| | Pressure tapped at the wrong place (regulator with external control line). | → Reconnect the control line at another point. → Do not connect the control line at pipe bends or necks. |
| | The restriction in the control line for pressure tapping is missing. | → Install a restriction. |
| Loud noises | High flow velocity, cavitation. | → Check the sizing. → Install larger regulator, if necessary. |
| Leakage at the inspection bore | Defective operating diaphragm | → Replace damaged diaphragm. |
| Leakage at the diaphragm stem | Dirt in the seal of the actuator casing and diaphragm stem | → Replace the diaphragm stem and actuator casing. |
| Red mark appears at the diaphragm rupture indicator. | Defective operating diaphragm | → Contact SAMSON's After-sales Service to replace a damaged operating diaphragm. |

NOTICE

Risk of TÜV approval (based on AGFW worksheet FW 504) for Types 44-3 and 44-9 becoming void.

Consult SAMSON's After-sales Service before you change parts or perform service or repair work on TÜV-tested Type 44-3 and Type 44-9 Regulators.

9 Malfunctions

The malfunctions listed in Table 5 are caused by mechanical faults and incorrect regulator sizing. In the simplest case, the functioning can be restored following the recommended action. Special tools may be required for repair work.

Exceptional operating and installation conditions may lead to changed situations that may affect the control response and lead to malfunctions. For troubleshooting, the conditions, such as installation, process medium, temperature and pressure conditions, must be taken into account.

SAMSON's After-sales Service can help during troubleshooting. Further information is available in Chapter 11.1.

SAMSON recommends removing the regulator from the pipeline before repairing it.



Tip

SAMSON's After-sales Service can support you in drawing up an inspection and test plan for your plant.



Note

Contact SAMSON's After-sales Service for malfunctions not listed in the table.

10 Decommissioning and removal

DANGER

Risk of bursting in pressure equipment.

Regulators and pipelines are pressure equipment. Improper opening can lead to bursting of the regulator.

- Before starting any work on the regulator, depressurize all plant sections affected as well as the regulator.
- Drain the process medium from the plant sections affected as well as from the regulator.
- Wear personal protective equipment.

WARNING

Risk of personal injury due to residual process medium in the regulator.

While working on the regulator, residual process medium can escape and, depending on its properties, may lead to personal injury, e.g. (chemical) burns.

Wear protective clothing, safety gloves and eye protection.

WARNING

Risk of burn injuries due to hot or cold components and pipeline.

Regulator components and the pipeline may become very hot or cold. Risk of burn injuries.

- Allow components and pipelines to cool down or warm up to the ambient temperature.

– Wear protective clothing and safety gloves.

10.1 Decommissioning

To decommission the regulator for service and repair work or disassembly, proceed as follows:

1. Close the shut-off valve on the upstream side of the regulator.
2. Close the shut-off valve on the downstream side of the regulator.
3. Completely drain the pipelines and regulator.
4. Depressurize the plant. Shut off or disconnect the control line, if installed.
5. If necessary, allow the pipeline and device to cool down or warm up to the ambient temperature.
6. Remove the regulator from the pipeline.

10.2 Disposal



SAMSON is a producer registered at the following European institution ► <https://www.samsongroup.com/en/about-samson/environment-social-governance/material-compliance/waste-electrical-and-electronic-equipment-veee-and-its-safe-disposal/>.
WEEE reg. no.: DE 62194439

Information on substances listed as substances of very high concern (SVHC) on the candidate list of the REACH regulation can be found in the document "Additional Information on Your Inquiry/Order", which is added to the order documents, if applicable. This document includes the assigned SCIP number, which can be entered into the database on the European Chemicals Agency (ECHA) website (► <https://www.echa.europa.eu/scip-database>) to find out more information on the SVHC.

Note

SAMSON can provide you with a recycling passport on request. Simply e-mail us at aftersaleservice@samsongroup.com giving details of your company address.

Tip

On request, SAMSON can appoint a service provider to dismantle and recycle the product as part of a distributor take-back scheme.

- Observe local, national and international refuse regulations.
- Do not dispose of components together with your other household waste.

11 Appendix

11.2 Spare parts

11.1 After-sales service

Contact SAMSON's After-sales Service for support concerning service or repair work or when malfunctions or defects arise.

E-mail address

You can reach our after-sales service at aftersaleservice@samsongroup.com.

Addresses of SAMSON AG and its subsidiaries

The addresses of SAMSON, its subsidiaries, representatives and service facilities worldwide can be found on our website (▶ www.samsongroup.com) or in all SAMSON product catalogs.

To assist diagnosis and in case of an unclear mounting situation, specify the following details (so far as possible). See Chapter 2:

- Device type and nominal size
- Model number or material number
- Upstream and downstream pressure
- Temperature and process medium
- Min. and max. flow rate
- Is a strainer installed?
- Installation drawing showing the exact location of the regulator and all the additionally installed components (shut-off valves, pressure gauge etc.)

Position numbers

| | |
|---------|-------------------------|
| 2 | Plug |
| 7 | Restriction assembly |
| 15 | O-ring |
| 25 | Screw (plug) |
| 27 | Plug nipple |
| 28 | Screw plug |
| 30 | Body |
| 35 | Threaded seat |
| 53 | Nut |
| 56 | Nut |
| 57 | Nut |
| 58 | Lock nut |
| 70...78 | Compression spring |
| 83 | Diaphragm stem |
| 90 | Diaphragm plate |
| 95 | Spring plate |
| 103 | Washer |
| 112 | Diaphragm case assembly |
| 116 | Pipe |
| 125 | Diaphragm |
| 130 | Screw |
| 134 | O-ring |
| 150 | Axial needle bearing |
| 155 | Screw fitting |

DN 15 to 25

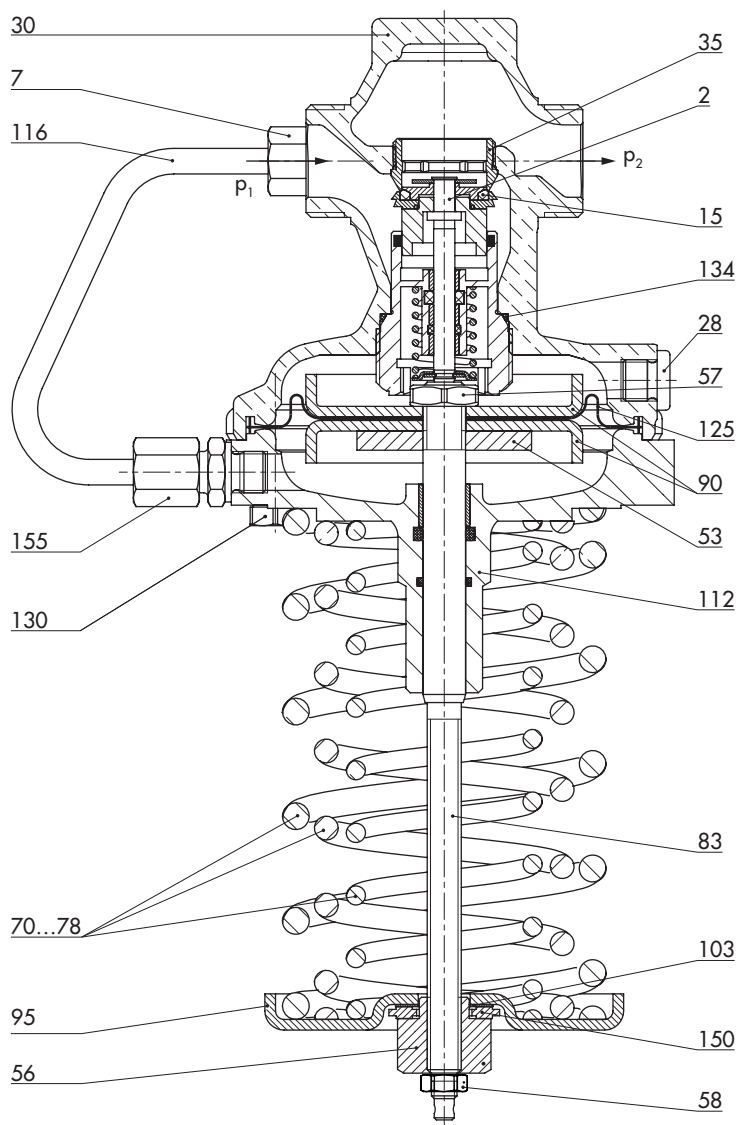

DN 32 to 50

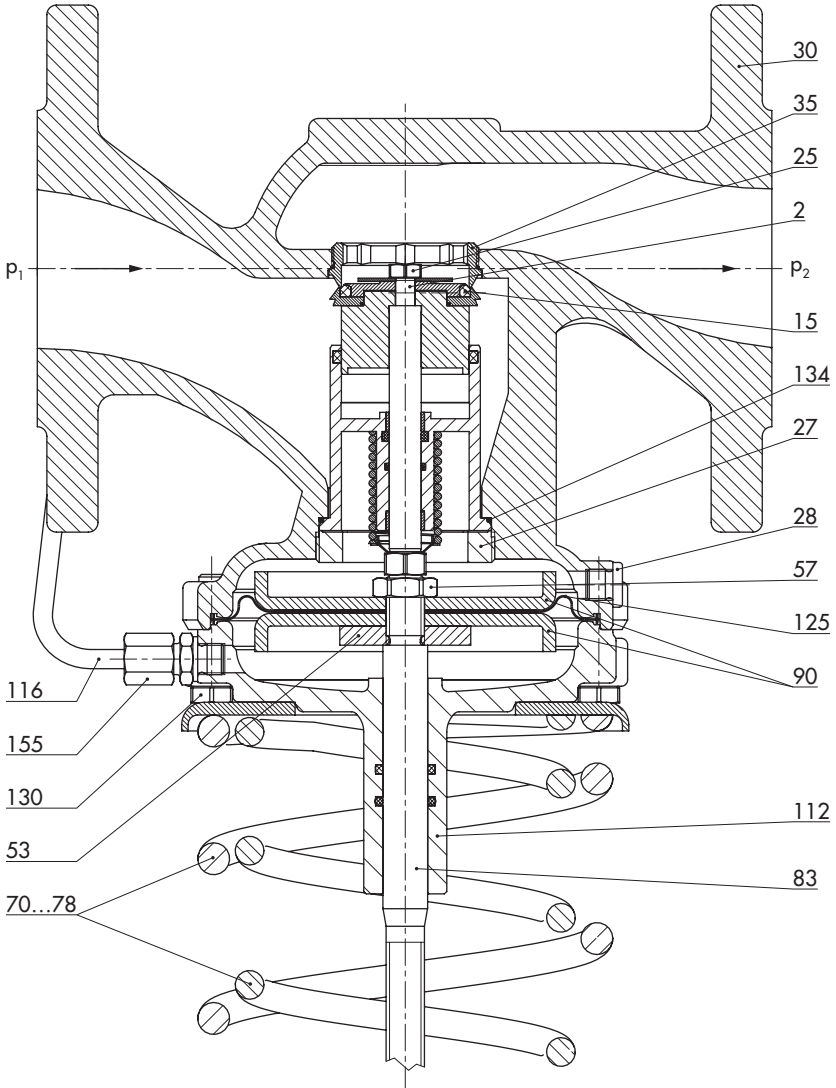

12 Certificates

The EU declarations of conformity are included on the next pages:

- EU declaration of conformity in compliance with Pressure Equipment Directive 2014/68/EU

EU DECLARATION OF CONFORMITY
TRANSLATION



Module A

For the following products, SAMSON hereby declares under its sole responsibility:

| Devices | Series | Type | Version |
|---|---|---|--|
| Self-operated Regulators | 43 | 2432 | DIN EN, body, CC499K and EN-GJS-400-18-LT, DN 50, PN 25, fluids G2, L2, L1 ¹⁾ |
| | 43 | 2436 | DIN EN, body, CC499K and EN-GJS-400-18-LT, DN 50, PN 25, fluids G2, L2, L1 ¹⁾ |
| | 43 | 2437 | DIN EN, body, CC499K and EN-GJS-400-18-LT, DN 50, PN 25, fluids G2, L2, L1 ¹⁾ |
| | --- | 2111 | DIN EN, body, EN-GJS-400-18-LT, DN 50, PN 25, fluids G2, L2, L1 ¹⁾ DIN EN, body, 1.0619 and 1.4408, DN 40-50, PN 40, fluids G2, L2, L1 ¹⁾ ANSI, body, A216 WCC and A351 CF8M, NPS 1½-2, Class 300, fluids G2, L2, L1 ¹⁾ |
| Three-way valve | --- | 2119 | DIN EN, body, EN-GJL-250 and 1.0619, DN 65-125, PN 16, fluids G2, L2, L1 ¹⁾ |
| | | | DIN EN, body, 1.0619, DN 50-80, PN 25, fluids G2, L2, L1 ¹⁾ |
| | | | DIN EN, body, 1.0619 and 1.4408, DN 40-50, PN 40, fluids G2, L2, L1 ¹⁾ |
| | | | ANSI, body, A216 WCC and A351 CF8M, NPS 2½-4, Class 150, fluids G2, L2, L1 ¹⁾ ANSI, body, A216 WCC and A351 CF8M, NPS 1½, Class 300, fluids G2, L2, L1 ¹⁾ |
| Control valve | --- | 3222 | DIN EN, body, EN-GJS-400-18-LT, DN 50, PN 25, fluids G2, L2, L1 ¹⁾ |
| | | | DIN EN, body, CC499K, DN 32-40, PN 25, all fluids |
| Three-way valve | --- | 3226 | DIN EN, body, CC499K, DN 50, PN 25, fluids G2, L2 ²⁾ |
| Three-way valve | --- | 3260 | DIN EN, body, EN-GJL-250, DN 65-200, PN 16, fluids G2, L2 ²⁾ |
| Globe valve Three-way valve | V2001 | 3531 | DIN EN, body, EN-GJS-400-18-LT, DN 50-80, PN 25, fluids G2, L2, L1 ¹⁾ |
| | | 3535 | DIN EN, body, 1.0619 and 1.4408, DN 32-40, PN 25, all fluids ANSI, body, A216 WCC and A351 CF8M, NPS 1½-2, Class 150, all fluids |
| Control valve | --- | 3214 | DIN EN, body, EN-GJL-250, DN 65-125, PN 16, fluids G2, L2, L1 ¹⁾ |
| | | | DIN EN, body, EN-GJS-400-18-LT, DN 50-80, PN 25, fluids G2, L2, L1 ¹⁾ |
| | | | ANSI, body, A126 B, NPS 3-4, Class 125, fluids G2, L2, L1 ¹⁾ |
| | | | ANSI, body, A216 WCC and A351 CF8M, NPS 1½-2, Class 150, all fluids |
| Self-operated Regulators | 42 | 2423 | DIN EN, body, EN-GJL-250 and EN-GJS-400-18-LT, DN 65-125, PN 16, fluids G2, L2, L1 ¹⁾ |
| | | | DIN EN, body, EN-GJS-418-LT, DN 50-80, PN 25, fluids G2, L2, L1 ¹⁾ |
| | | | DIN EN, body, 1.0619 and 1.4408, DN 32-50, PN 16, all fluids |
| | | | DIN EN, body, 1.0619 and 1.4408, DN 32-40, PN 25, all fluids ANSI, body, A126 B, NPS 3-4, Class 125, fluids G2, L2, L1 ¹⁾ |
| | ANSI, body, A216 WCC and A351 CF8M, NPS 1½-2, Class 150, all fluids | | |
| | 42 | 2422 | DIN EN, body, EN-GJL-250 and EN-GJS-400-18-LT, DN 65-125, PN 16, fluids G2, L2, L1 ¹⁾ |
| | | | DIN EN, body, EN-GJS-400-18-LT, DN 50-80, PN 25, fluids G2, L2, L1 ¹⁾ |
| | | | DIN EN, body, 1.0619, 1.4408 and 1.6220+QT, DN 32-50, PN 16, all fluids |
| ANSI, body, A126 B, NPS 3-4, Class 125, fluids G2, L2, L1 ¹⁾ | | | |
| ANSI, body, A216 WCC, A351 CF8M and A352 LCC, NPS 1½-2, Class 150, all fluids | | | |
| Strainers | 1N/1NI | 2601 | DIN EN, body, CB762S, G 2 (DN50), PN25, fluids G2, L2 ³⁾ |
| Strainers | 2N/2NI | 2602 | DIN EN, body, EN-GJL-250, DN 200-250, PN 10, fluids G2, L2, L1 ¹⁾ |
| | | | DIN EN, body, EN-GJL-250, DN 65-125, PN 16, fluids G2, L2, L1 ¹⁾ |
| | | | DIN EN, body, EN-GJS-400-18-LT, DN 100-125, PN 16, fluids G2, L2, L1 ¹⁾ |
| | | | DIN EN, body, EN-GJS-400-18-LT, DN 50-80, PN 25, fluids G2, L2, L1 ¹⁾ DIN EN, body, 1.4408, DN 32-50, PN 16, all fluids |
| Self-operated Regulators | --- | 2373/2375 | ANSI, body, A995 4A and A995 5A, NPS 1½-2, Class 150, all fluids |
| | | 2440 (44-0B) 2441 (44-1B) 2446 (44-5B) | DIN EN, body, EN-GJS-400-18-LT, DN 50, PN 25, fluids G2, L2, L1 ¹⁾ |
| | | 2442 (44-2) 2443 (44-3) 2444 (44-4) 2447 (44-7) 2449 (44-9) | DIN EN, body, EN-GJS-400-18-LT and CC499K, DN 50, PN 25, fluids G2, L2, L1 ¹⁾ |
| | | | |
| | | | |

Revision 01

Classification: Public · SAMSON AKTIENGESELLSCHAFT · Weismuellerstrasse 3 · 60314 Frankfurt am Main, Germany Page 1 of 3

EU DECLARATION OF CONFORMITY
TRANSLATION



| Devices | Series | Type | Version |
|--------------------------|--------|---|---|
| Self-operated Regulators | 45 | 2451 (45-1) | DIN EN, body, EN-GJS-400-18-LT and CC499K, DN 50, PN 25, fluids G2, L2, L1 ¹⁾ |
| | | 2452 (45-2) | |
| | | 2453 (45-3) | |
| | | 2454 (45-4) | |
| | | 2456 (45-6) | |
| | 46 | 2465 (46-5) | DIN EN, body, EN-GJS-400-18-LT and CC499K, DN 50, PN 25, fluids G2, L2, L1 ¹⁾ |
| | | 2486 (46-6) | |
| | | 2487 (46-7) | |
| | 47 | 2471 (47-1) | DIN EN, body, EN-GJS-400-18-LT and CC499K, DN 50, PN 25, fluids G2, L2, L1 ¹⁾ |
| | | 2474 (47-4) | |
| | 48 | 2488 | DIN EN, body, EN-GJS-400-18-LT and CC499K, DN 50, PN 25, fluids G2, L2, L1 ¹⁾ |
| | | 2489 | |
| | 40 | 2405 | DIN EN, body, EN-GJS-400-18-LT, DN 50, PN 25, fluids G2, L2, L1 ¹⁾ |
| | | | ANSI, body, A216 WCC and A351 CF8M, NPS 1½-2, Class 150, all fluids |
| | | 2406 | DIN EN, body, EN-GJL-250, DN 65-125, PN 16, fluids G2, L2, L1 ¹⁾ |
| | | | DIN EN, body, EN-GJS-400-18-LT, DN 50, PN 25, fluids G2, L2, L1 ¹⁾ |
| | 41 | 2412 | ANSI, body, A126 B, NPS 3-4, Class 125, fluids G2, L2, L1 ¹⁾ |
| | | | DIN EN, body, EN-GJL-250, DN 65-100, PN 16, fluids G2, L2, L1 ¹⁾ |
| | | 2417 | DIN EN, body, EN-GJS-400-18-LT, DN 50-80, PN 25, fluids G2, L2, L1 ¹⁾ |
| | | | ANSI, body, A216 WCC and A351 CF8M, NPS 1½-2, Class 150, all fluids |
| | 42 | 2421 RS | DIN EN, body, 1.0619, 1.4408, 1.4571 and 1.4401/1.4404, DN 32-50, PN 16, all fluids |
| | | | DIN EN, body, 1.0619, 1.4408, 1.4571 and 1.4401/1.4404, DN 32-40, PN 25, all fluids |
| | | 2421 RS | ANSI, body, A216 WCC, A351 CF8M and A182 F316/A182 F316L, NPS 1½-2, Class 150, all fluids |
| | | | DIN EN, body, 1.0619, DN 250, PN 40, fluids L1 ¹⁾ |
| | --- | 2331 | DIN EN, body, EN-GJL-250, DN 65-200, PN 16, fluids G2, L2 ²⁾ |
| | | | DIN EN, body, EN-GJS-400-18-LT, DN 65-150, PN 16, fluids G2, L2 ²⁾ |
| | | 2337 | DIN EN, body, EN-GJS-400-18-LT, DN 65-125, PN 25, fluids G2, L2 ²⁾ |
| | | | DIN EN, body 1.0619, DN 65-200, PN 16, fluids G2, L2 ²⁾ |
| --- | 2333 | DIN EN, body 1.0619, DN 65-100, PN 40, fluids G2, L2 ²⁾ | |
| | | DIN EN, body 1.0619, DN 250, PN 40, fluids L1 ¹⁾ | |
| --- | 2335 | DIN EN, body, EN-GJL-250, DN 65-125, PN 16, fluids G2, L2, L1 ¹⁾ | |
| | | DIN EN, body, EN-GJS-400-18-LT, DN 65-80, PN 25, fluids G2, L2, L1 ¹⁾ | |
| --- | 2334 | ANSI, body, A126 B, NPS 3-4, Class 125, fluids G2, L2, L1 ¹⁾ | |
| | | DIN EN, body, EN-GJL-250, DN 65-125, PN 16, fluids G2, L2, L1 ¹⁾ | |
| | 2404-1 | DIN EN, body, EN-GJS-400-18-LT, DN 65-125, PN 16, fluids G2, L2, L1 ¹⁾ | |
| | | DIN EN, body, EN-GJS-400-18-LT, DN 65-80, PN 25, fluids G2, L2, L1 ¹⁾ | |
| --- | 2404-2 | ANSI, body, A126 B, NPS 3-4, Class 125, fluids G2, L2, L1 ¹⁾ | |
| | | DIN EN, body, EN-GJL-250, DN 65-125, PN 16, fluids G2, L2, L1 ¹⁾ | |

¹⁾ Gases according to Article 4(1)(c.i), second indent
Liquids according to Article 4(1)(c.ii)

²⁾ Gases according to Article 4(1)(c.i), second indent
Liquids according to Article 4(1)(c.ii), second indent

EU DECLARATION OF CONFORMITY
TRANSLATION



That the products mentioned above comply with the requirements of the following standards:

| | | |
|--|------------|-----------------|
| Directive of the European Parliament and of the Council on the harmonization of the laws of the Member States relating to the making available on the market of pressure equipment | 2014/68/EU | of 15. May 2014 |
| Applied conformity assessment procedure for fluids according to Article 4(1) | Module A | |

Technical standards applied: DIN EN 12516-2, DIN EN 12516-3, ASME B16.34

Manufacturer: SAMSON AG, Weismüllerstraße 3, 60314 Frankfurt am Main, Germany

Frankfurt am Main, 05. June 2024

ppc. Norbert Tollas
Senior Vice President
Global Operations

i.V. Peter Scheermesser
Director
Product Maintenance & Engineered Products

Revision 01

Classification: Public · SAMSON AKTIENGESELLSCHAFT · Weismuellerstrasse 3 · 60314 Frankfurt am Main, Germany

Page 3 of 3



SAMSON AKTIENGESELLSCHAFT
Weismüllerstraße 3 · 60314 Frankfurt am Main, Germany
Phone: +49 69 4009-0 · Fax: +49 69 4009-1507
samson@samsongroup.com · www.samsongroup.com