

MOUNTING AND OPERATING INSTRUCTIONS



EB 26l

Translation of the original manual



Multi-way ball valve BR 26l, BR 26t, BR 26v and BR 26x
Horizontal and vertical in DIN and ANSI versions
to combine with actuators

February 2024 edition



Note regarding this installation and operating manual

This Installation and Operating Manual (EB) provides guidance for safe assembly and operation.

The notes and instructions in this EB are binding when handling PFEIFFER devices. The figures and illustrations in this EB are examples and must therefore be considered as such.

- ⇒ For safe and correct use, read this EB carefully prior to use and keep it for later reference.
- ⇒ In the case of questions that go beyond the scope of this EB, please contact the After Sales Service at PFEIFFER Chemie-Armaturenbau GmbH.
- ⇒ This manual only applies to the ball valve itself, the respective additional manual applies for the mounted actuator.

Definition of signal words

DANGER

Hazardous situations that lead to death or serious injuries

WARNING

Situations that can lead to death or serious injuries

NOTE

Property damage and malfunctions

Info

Additional information

Tip

Recommended action

Content

1	Safety instructions and safety measures	1-1
1.1	Notes regarding possible severe personnel injury	1-2
1.2	Notes regarding possible personnel injury	1-2
1.3	Notes regarding possible property damage	1-3
1.4	Warning notes on the device	1-4
2	Markings on the device	2-1
2.1	Type plate	2-2
2.1.1	Actuator type plate	2-2
2.2	Material identification	2-2
3	Design and principle of operation	3-1
3.1	Variants	3-1
3.2	Additional fittings	3-2
3.3	Attachments	3-2
3.4	Technical data	3-2
3.5	Multi-way ball valve assembly	3-2
3.5.1	Assembly of the horizontal 3-way ball valve BR 26l / BR 26t, DN 15 to 32 and NPS $\frac{1}{2}$ to 1 $\frac{1}{4}$	3-2
3.5.2	Assembly of the horizontal 3-way ball valve BR 26l / BR 26t, DN 40 to 200 and NPS $1\frac{1}{2}$ to 8	3-5
3.5.3	Assembly of the vertical 3-way ball valve BR 26v, DN 15 to 32 and NPS $\frac{1}{2}$ to 1 $\frac{1}{4}$	3-7
3.5.4	Assembly of the vertical 3-way ball valve BR 26v, DN 40 to 200 and NPS $1\frac{1}{2}$ to 8	3-10
3.5.5	Assembly of the horizontal 4-way ball valve BR 26x, DN 15 to 32 and NPS $\frac{1}{2}$ to 1 $\frac{1}{4}$	3-12
3.5.6	Assembly of the horizontal 4-way ball valve BR 26x, DN 40 to 200 and NPS $1\frac{1}{2}$ to 8	3-15
3.5.7	Assembly of the 5/4-way ball valve BR 26x, DN 25 to 32 and NPS1 to 1 $\frac{1}{4}$	3-17
3.5.8	Assembly of the 5/4-way ball valve BR 26x, DN 40 to 200 and NPS $1\frac{1}{2}$ to 8	3-19
4	Shipment and on-site transport	4-1
4.1	Accepting delivery	4-1
4.2	Unpacking the multi-way ball valve	4-1
4.3	Transporting and lifting the multi-way ball valve	4-1
4.3.1	Transporting	4-1
4.3.2	Lifting	4-1
4.3.3	Lifting points on the body	4-2
4.3.4	Lifting points on the bracket	4-2
4.4	Storing the multi-way ball valve	4-3
5	Installation	5-1
5.1	Installation conditions	5-1
5.2	Preparing for assembly	5-1
5.3	Assembling the multi-way ball valve and actuator	5-1
5.4	Installing the multi-way ball valve in the pipe	5-2
5.4.1	General	5-2
5.4.2	Switching position and fail-safe position	5-2
5.4.3	Installing the multi-port ball valve	5-3
5.5	Checking the assembled ball valve	5-4
5.5.1	Functional test	5-4
5.5.2	Pressure test of the pipe section	5-4
5.5.3	Rotary movement	5-4
5.5.4	Fail-safe position	5-4

Content

6 Start-up	6-1
7 Operation	7-1
8 Malfunction	8-1
8.1 Detecting and rectifying errors	8-1
8.2 Carrying out emergency measures	8-2
9 Servicing	9-1
9.1 Periodic tests	9-1
9.2 Maintenance work	9-2
9.2.1 Replacing the seat rings and ball	9-2
9.3 Ordering spare parts and consumables	9-2
10 Decommissioning	10-1
11 Removal	11-1
11.1 Removing the multi-way ball valve from the pipe	11-1
11.2 Disassembling the actuator	11-1
12 Repairs	12-1
12.1 Replacing the V-ring packing	12-1
12.2 Replacing the seat ring and the ball	12-1
12.2.1 Disassembly of the multi-port ball valve, DN 15 to 32 and NPS $\frac{1}{2}$ to 1 $\frac{1}{4}$	12-1
12.2.2 Disassembly of the multi-port ball valve, DN 40 to 200 and NPS1 $\frac{1}{2}$ to 8	12-1
12.3 Additional repairs	12-4
12.4 Sending devices to PFEIFFER	12-4
13 Disposal	13-1
14 Certificates	14-1
15 Annex	15-1
15.1 Tightening torques, lubricant and tools	15-1
15.1.1 Tightening torques	15-1
15.1.2 Lubricant	15-2
15.1.3 Tools	15-2
15.2 Spare parts	15-3
15.2.1 Spare parts of the multi-way ball valve DN 15 bis 32 and NPS $\frac{1}{2}$ bis 1 $\frac{1}{4}$	15-4
15.2.2 Spare parts of the multi-way ball valve DN 40 bis 200 and NPS1 $\frac{1}{2}$ bis 8	15-6
15.3 Service	15-8

1 Safety instructions and safety measures

Intended use

The multi-way ball valve BR 26l, BR 26t, BR 26v and BR 26x are manually operated in combination with an actuator for the regulation of the volume flow, pressure and temperature of fluid, gaseous or vaporous media.

- The ball valve and its actuator are designed for precisely defined conditions (e.g. operating pressure, utilised medium, temperature).
- Therefore the operator must make sure that the ball valve is only used when the conditions of use comply with the design criteria defined in the order.
- If the operator would like to use the ball valve in other applications or environments, they must contact PFEIFFER.
- Manual multi-way ball valves are only intended for shut off, divert, divide the flow or to mix several flows within the permitted pressure and temperature limits, depending on the design and position of the ball, after installation in a pipe system.
- Automated multi-way ball valves are only intended for shut off, divert, divide the flow or to mix several flows within the permitted pressure and temperature limits, depending on the design and position of the ball, after installation in a pipe system and connection of the actuator to the control system.
- The data sheet contains the permissible pressure and temperature range for these ball valves ► TB 26l.
- The safety regulations that apply to the pipe system in which the ball valves are installed and to the control system to which the actuator is connected also apply to the ball valves.

This manual only provides safety instructions that are to be observed additionally for ball valves.

There may be additional safety instructions in the manuals for the actuator assemblies.

- It is assumed that this chapter is observed when using the valve as intended.

Reasonably foreseeable erroneous use and unintended use

The ball valve is not suited for the following areas of use:

- Use outside of the technical data and the limits defined by the design.
- Use outside of the limited defined by the peripheral devices installed on the ball valve.

Furthermore, the following activities are considered unintended use:

- Use of third-party spare parts.
- Performance of maintenance and repair work that is not described.

Qualification of operating personnel

The ball valve may only be disassembled, dismantled, assembled and commissioned by qualified specialist personnel trained in pressurised pipes who are familiar with the assembly, commissioning and operation of this product.

- Specialist personnel in terms of this installation and operating manual are persons who, on the basis of their vocational education, knowledge and experience and knowledge of the relevant standards, are capable of evaluating the assigned tasks and identifying possible hazards.

Personal protective equipment

Depending on the utilized medium, PFEIFFER recommends the following protective equipment:

- Protective garments, protective gloves and eye protection when using hot, cold, aggressive and/or corrosive media.
- Hearing protection when working near the valves.
- Request additional protective equipment from the plant operator.

Prohibition of modifications

Changes to the product are not permitted without consulting PFEIFFER. Non-compliance invalidates the warranty and product guarantee. PFEIFFER shall not be held liable for any resulting property damage or personal injury.

Protective devices

In the case of a power supply failure, the automated ball valve automatically switches to a certain fail-safe position, see "Fail-safe positions" in Chapter "3 Design and principle of operation".

- The fail-safe position corresponds to the effective direction and is indicated on the type plate of the actuators, see the actuator documentation.
- The valve is to be included in the equipotential bonding of the plant.

Warning of residual risks

To prevent personal injury or property damage, the operator and operating personnel must use suitable measures to prevent the hazards that can result from the flow medium and operating pressure as well as the signal pressure and moving parts of the ball valve.

- Therefore, the operator and operating personnel must observe all the hazard information, warning information and information in this installation and operating manual.

Obligation of the operator to exercise diligence

The operator is responsible for proper operation as well as compliance with the safety regulations.

- The operator is responsible for providing operating personnel with this installation and operating manual as well as the applicable documents and to provide instructions on proper operation.
- Furthermore, the operator must ensure that operating personnel and third parties are not endangered.

It is not the responsibility of PFEIFFER and therefore when using the ball valve ensure that:

- The ball valve is only used as intended as described in this chapter.

- An actuator unit that is subsequently installed on the ball valve is adapted to the ball valve and the max. torque is observed, and is correctly adjusted in the end positions, and in particular in the opening position of the ball valve.
- The pipe system and control system are properly installed and regularly checked. The wall thickness of the ball valve body is measured such that an additional load of the usual magnitude is taken into account for a pipe system installed properly in this way.
- The valve is connected properly to these systems.
- The customary flow rates in continuous operation are not exceeded in this pipe system.
- PFEIFFER is contacted in the case of abnormal operating conditions, such as vibrations, hydraulic shock, cavitation and also small amounts of solid matter in the medium, especially abrasive matter.

Obligation of operating personnel to exercise diligence

Operating personnel must be familiar with this installation and operating manual and the applicable documents and comply with the indicated hazard information, warning information and other information. Furthermore, operating personnel must be familiar with the applicable regulations concerning occupational safety and accident prevention and observe them.

Applicable standards and directives

- The ball valves fulfil the requirements of the European Pressure Equipment Directive 2014/68/EU and the European Machinery Directive 2006/42/EC.

In the case of ball valves provided with a CE marking, the Declaration of Conformity provides information about the conformity assessment procedure that was used.

The corresponding declarations of conformity are available in the Annex of this EB, see chapter "14 Certificates".

- According to an ignition hazard assessment according to DIN EN ISO 80079-36, PFEIFFER valves do not have any own potential ignition sources and therefore are not subject to Directive 2014/34/EU.

CE marking based on this standard is not permitted. The inclusion of valves in the equipotential bonding of a plant applies independently of the directive for all metal parts in potentially explosive areas.

1.1 Notes regarding possible severe personnel injury

DANGER

Hazards and ineffectiveness of the warranty!

In the case of non-compliance with the following hazard and warning information, hazards may arise and the warranty provided by PFEIFFER may become invalid.

- ⇒ Observe the following hazards and warning information.
- ⇒ Contact PFEIFFER in the case of questions.

DANGER

Hazards and damage due to unsuitable ball valves!

Ball valves whose permissible pressure/temperature range (=“rating”) is not sufficient for the operating conditions can pose a danger to the user and cause damage to the pipe system.

- ⇒ Only operate ball valves whose permissible pressure/temperature range (=“rating”) is sufficient for the operating conditions. (see data sheet ► TB 261)

Risk of bursting of the pressure equipment!

Ball valves and pipes are pressure equipment. Improper opening can cause the bursting of ball valve components.

- ⇒ Observe the maximum permissible pressure for the ball valve and plant.
- ⇒ Before working on the ball valve, depressurise the concerned plant parts and the ball valve.
- ⇒ Before removing the ball valve from the pipe, completely release the pressure in the pipe so that the medium does not escape uncontrolled from the line.
- ⇒ Bring the ball valve into the open position so the pressure is released from the ball.
- ⇒ Empty the medium from the concerned plant parts and ball valve. (Wear protective equipment)

1.2 Notes regarding possible personnel injury

WARNING

Danger of burning due to hot or cold components and pipes!

Depending on the utilised medium, ball valve components and pipes can become very hot or very cold and cause burns upon contact.

- ⇒ The ball valves must be protected against contact in the case of operating temperatures $>+50\text{ °C}$ or $<-20\text{ °C}$ together with the pipe connections.

Danger of crushing due to moving parts!

The ball valve contains moving parts (actuator stem, control shaft and hand lever) that can lead to crushing if reaching into it.

- ⇒ Do not reach into the yoke during operation.
- ⇒ When working on the ball valve, interrupt and lock pneumatic energy and the control signal.

Danger of injury during the switching operation if performing test runs on ball valves not installed in the pipe!

- ⇒ Do not reach into the ball valve. This can result in serious injuries.

Danger of injury due to venting the actuator!

During operation, when regulating or opening and closing the ball valve, the actuator can be ventilated.

- ⇒ Install the ball valve such that the actuator does not ventilate at eye level.
- ⇒ Use suitable silencers and plugs.
- ⇒ Wear eye protection and, if necessary, hearing protection when working near valves.

! WARNING**Danger of injury due to preloaded springs!**

Ball valves that are equipped with preloaded actuator springs are under mechanical tension.

- ⇒ Before working on the actuator, release the compression from the preloaded springs, see the corresponding actuator documentation.

Danger of injury due to residual medium in the ball valve!

When a ball valve must be removed from a pipe, medium can escape from the pipe or the ball valve.

- ⇒ In the case of media that is harmful to health or hazardous, the pipe must be completely emptied before a ball valve can be removed.
- ⇒ Pay attention to the afterflow of residuals or residuals that remain in dead spots.

Danger of injury due to the releasing of body screw connections!

If the body screw connections must be released, medium can escape from the ball valve.

- ⇒ The screw connections on the connection of the body parts may only be released or loosened after the ball valve has been removed.
- ⇒ During reassembly, tighten the screws according to Table 15-1 to Table 15-4 in Chapter "15.1.1 Tightening torques" using a torque wrench.

Hazards due to incorrect ball valve use!

The incorrect use of the ball valve can represent a hazard for the user and cause damage to the pipe system that are then no longer the responsibility of PFEIFFER.

- ⇒ The material selected for the parts of the ball valve that come into contact with the media must be suitable for the utilised media, pressures and temperatures.

Dangers due to use as an end fitting!

During normal operation, in particular with gaseous, hot and/or hazardous media, spraying medium can cause hazards. It must be kept in mind that the media is usually hazardous!

- ⇒ A blind flange must be assembled on the free connecting pieces or the ball valve must be secured against unauthorised actuation.
- ⇒ If a ball valve used as an end fitting in a pressurised line is opened, this may only be done with extreme caution so that the escaping medium does not cause any damage.

1.3 Notes regarding possible property damage

! NOTE**Damage to the ball valve due to contamination!**

Contamination (e.g. solid particles) in the pipes can damage the ball valve.

- ⇒ The plant operator is responsible for cleaning the pipes in the plant.
- ⇒ Rinse the pipes prior to commissioning.
- ⇒ Observe the maximum permissible pressure for the ball valve and plant.

Damage to the ball valve due to unsuitable medium properties!

The ball valve is designed for a medium with certain properties. Other media can damage the ball valve.

- ⇒ Only use a medium that corresponds to the design criteria.

Damage to the ball valve and leakage due to excessively high or low tightening torques!

The ball valve components must be tightened with specific torques. Deviating torques can lead to ball valve leakage or damage.

- ⇒ Excessively tightened components are subject to increased wear.
- ⇒ Insufficiently tightened components can cause leakage.
- ⇒ Observe the tightening torques, see Table 15-1 to Table 15-4 in Chapter "15.1.1 Tightening torques".

Damage to the ball valve due to an impermissible pressure increase!

The ball valve body may contain small amounts of medium in the closed and open position.

- ⇒ Use a ball valve with an optional relief bore if it is possible that the closed area of the ball filled with medium can heat up due to external heat. (This prevents an impermissible pressure increase due to a change in the condition of the unit.)

Deviation of the breakaway and actuating forces due to non-actuation of the ball valve!

Depending on the period of time of non-actuation, the breakaway and actuation forces can deviate considerably from the actuating power data in the data sheet.

It is recommended to actuate the ball valve at regular intervals.

- ⇒ In consideration of the design, actuation must take place during the year.
- ⇒ Indicate the duration of non-actuation when making an enquiry, so that this condition is taken into consideration in the actuator design.
- ⇒ In the case of retrofitted actuators by the operator, the correct actuator design as regards the duration of non-actuation is no longer the responsibility of PFEIFFER.

Damage to the ball valve due to plant vibrations!

- ⇒ If necessary, secure hand-operated ball valves in the case of plant vibrations with a locking device to prevent it from moving by itself.

NOTE

Damage to the ball valve due to unsuitable tools!

Unsuitable tools can damage the ball valve.

⇒ Suitable tools are required to work on the ball valve, see Chapter "15.1.3 Tools".

Damage to the ball valve due to unsuitable lubricants!

Unsuitable lubricants can corrode and damage the surface.

⇒ The ball valve material requires suitable lubricants, see Chapter "15.1.2 Lubricants".

1.4 Warning notes on the device

Warning of moving parts

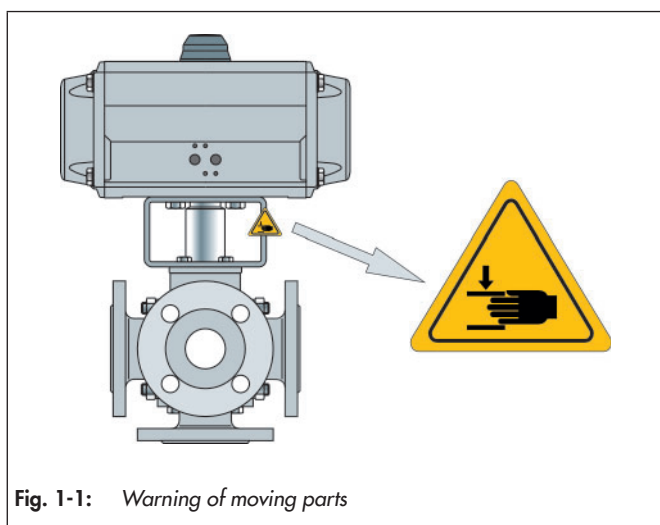

Fig. 1-1: Warning of moving parts

There is a danger of crushing due to the rotary movements of the actuator- and control shaft when reaching into the yoke as long as the pneumatic power is connected to the actuator. At the operator's request, a warning note can be attached to the valve.

2 Markings on the device

Each ball valve usually has the following marking.

Table 2-1: Marking on the type plate and on the body of the ball valve

Pos.	For	Marking	Remark
1	Manufacturer	PFEIFFER	Address see Chapter "15.3 Service"
2	Valve type	BR (and number value)	e.g. BR 26l = Series 26l, see the PFEIFFER catalogue
3	Body material	e.g. 1.4408	Material standard according to DIN EN 10213-4
4	Size	DN (and number value)	Number value in [mm], e.g. DN 80 / number value in [inches], e.g. NPS3
5	Maximum pressure	PN (and number value)	Number value in [bar], e.g. PN 40 / number value in [inches], e.g. c1 50 at room temperature
6	Max. permissible operating temperature	TS (and number value)	PS are TS are related values here at the max. permissible operating temperature with the max. permissible operating overpressure, see also the Pressure-Temperature Diagram in the data sheet ▶ TB 26l.
	Max. permissible operating pressure	PS (and number value)	
7	Test pressure	PT (and number value)	The test pressure must be observed depending on the device
8	Manufacturer number from 2018	e.g. 331234/001/001	33 1234 /001 /001
	Manufacturer number 2009 to 2017	e.g. 211234/001/001	21 1234 /001 /001
	Manufacturer number until 2008	e.g. 2071234/001/001	207 1234 /001 /001
9	Year of manufacture	e.g. 2023	upon customer request, the year of manufacture can also be indicated on the valve
10	Data/Matrix code		
11	Conformity	CE	Conformity is certified separately by PFEIFFER
	Code No.	0035	"Notified body" according to EU Directive = TÜV Rheinland Service GmbH
12	Flow direction	➔	Attention: see the note in Chapter "5.4 Installing the multi-way ball valve in the pipe"

i Info

Markings on the body and the type plate must be permanent so that the valve remains identifiable.

2.1 Type plate

2.1.1 Actuator type plate

See the corresponding actuator documentation.

2.2 Material identification

The ball valves are marked on the body with the material specification; see "Table 2-1: Marking on the type plate and on the body of the ball valve".

Further details can be obtained from PFEIFFER.

3 Design and principle of operation

Properties

- Exchangeable port seal made of TFM
- Shaft sealing by means of live-loaded V-ring packing
- Blowout-proof control shaft
- Connecting flange for actuators acc. to DIN ISO 521 1
- Face-to-face dimensions, Series 1 acc. to EN 558
- ISO port, light-duty series

Operating elements and functions

- Multi-way ball valve with hand lever
- Multi-way ball valve with manual gear
- Multi-way ball valve with pneumatic
 - 90° part-turn actuator (BR 26l, 26t and 26x)
 - 180° part-turn actuator, also centred (BR 26v)
 (Refer to the corresponding data sheet for more details)

Optional materials

- Special austenitic steel
- Duplex steels
- Hastelloy
- Titanium
- Other alloys on request

Function and principle of operation

The process medium can flow through the full port in the multi-way ball valves of the **BR 26l**, **BR 26t**, **BR 26v** and **BR 26x**. They are primarily used to divide media in the piping system.

The ball (4) rotates around the control shaft (5).

The rotary angle of the ball determines the direction of flow in the pipe.

The ball (4) is sealed by of exchangeable seat rings (7).

The control shaft is sealed by a PTFE V-ring packing (14) which is live-loaded by disc springs (12) located above the packing.

The control shaft that leads outside is fit with a hand lever.

Optionally a pneumatic rotary actuator or manual gear can be adapted.

Control positions

The setup position, and the control functions of the actuator are variable.

Depending on the specific customer requirements, the multi-way ball valve are constructed and equipped.

Information about the control positions and safety positions is listed in detail in Chapter 5.

3.1 Variants

- Various designs, see Fig. 3-1
- Special flow pattern
- Special flange version
- Cavity minimized
- Sterile connection
- Heating jacket
- Rinsing connections
- Low and high-temperature versions
- Special seat rings

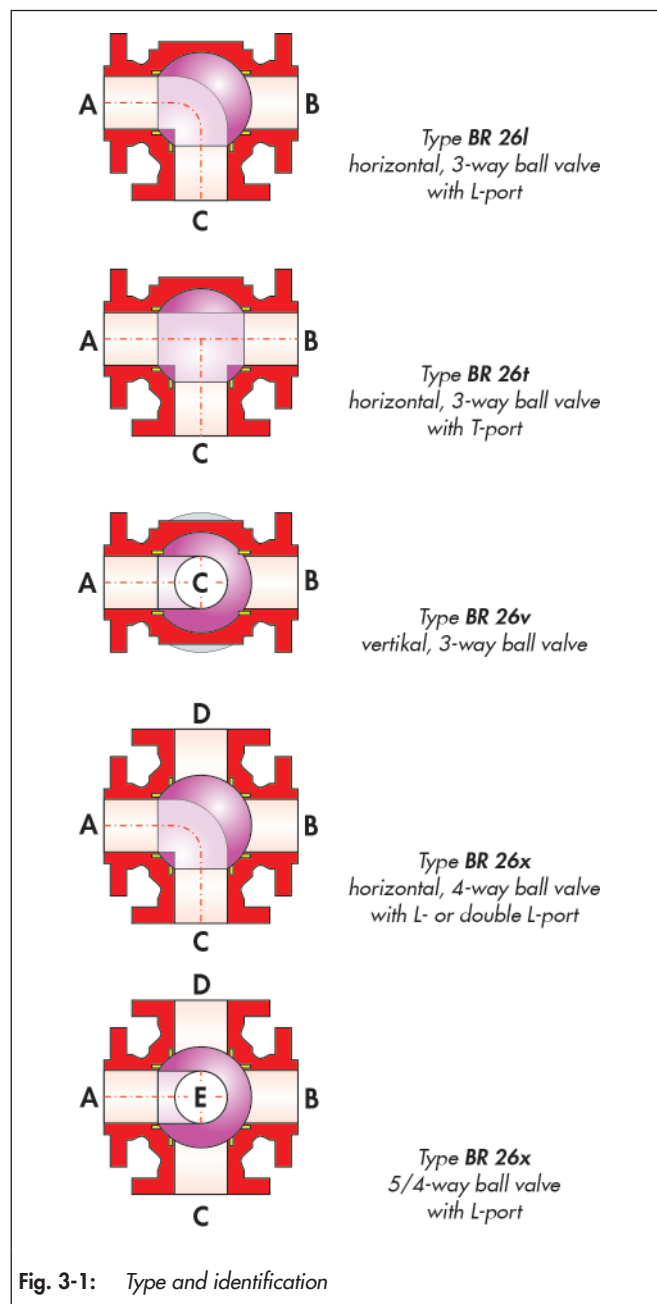

Fig. 3-1: Type and identification

3.2 Additional fittings

Strainer

PFEIFFER recommends installing a strainer in front of the ball valve. A strainer prevents the solid content in the medium from damaging the ball valve.

Bypass and shut-off valve

PFEIFFER recommends installing a shut-off valve in front of the strainer as well as behind the ball valve and to create a bypass. By means of the bypass, the entire plant does not have to be de-commissioned during maintenance and repair work on the ball valve.

Insulation

The ball valves can be insulated to reduce the passage of heat energy. Observe the notes in Chapter "5 Assembly".

Test connection

The test connection can be used to detect the stuffing box flange (e.g. G $\frac{1}{4}$ ") between the seat ring and the packing.

Grip protection

In the case of conditions of use that require a high level of safety (e.g. if the ball valve is freely accessible to untrained specialist personnel), PFEIFFER offers a safety guard to prevent the risk of crushing due to moving parts (actuator- and control shaft).

The risk assessment of the plant by the operator will indicate if the installation of this protective device is required for the safe operation of the ball valve in the plant.

3.3 Attachments

The following accessories are available for the ball valves either individually or in combination:

- Shaft extension (100 mm standard)
- Pneumatic and electric part-turn actuators
- Positioner
- Limit switch
- Solenoid valves
- Air supply stations

Other accessories are available according to the specifications.

3.4 Technical data

The type plates of the ball valve and actuator offer information about the valve version, see Chapter "2 Markings on the device".

Info

- Detailed information is available on the data sheet ► TB 26l.
- The documentation for the special ball valves BR 26l, BR 26t, BR 26v and BR 26x that are not described in this chapter can be requested from PFEIFFER.

3.5 Multi-way ball valve assembly

The ball valves BR 26l, BR 26t, BR 26v and BR 26x are produced with various designs so that they cannot be documented in one construction manual.

- Chapter 3.5.1 describes the assembly of the horizontal 3-way ball valves BR 26l and BR 26t, DN 15 to 32 and NPS $\frac{1}{2}$ to 1 $\frac{1}{4}$.
- Chapter 3.5.2 describes the assembly of the horizontal 3-way ball valves BR 26l and BR 26t, DN 40 to 200 and NPS $\frac{1}{2}$ to 8.
- Chapter 3.5.3 describes the assembly of the vertical 3-way ball valve BR 26v, DN 15 to 32 and NPS $\frac{1}{2}$ to 1 $\frac{1}{4}$.
- Chapter 3.5.4 describes the assembly of the vertical 3-way ball valve BR 26v, DN 40 to 200 and NPS $\frac{1}{2}$ to 8.
- Chapter 3.5.5 describes the assembly of the horizontal 4-way ball valve BR 26x, DN 15 to 32 and NPS $\frac{1}{2}$ to 1 $\frac{1}{4}$.
- Chapter 3.5.6 describes the assembly of the horizontal 4-way ball valve BR 26x, DN 40 to 200 and NPS $\frac{1}{2}$ to 8.
- Chapter 3.5.7 describes the assembly of the 5/4-way ball valve BR 26x, DN 25 to 32 and NPS1 to 1 $\frac{1}{4}$.
- Chapter 3.5.8 describes the assembly of the 5/4-way ball valve BR 26x, DN 40 to 200 and NPS $\frac{1}{2}$ to 8.

Preparation of the assembly

To assemble the ball valve, all parts must be prepared, e.g. the parts are carefully cleaned and placed on a soft mat (rubber mat or other). Keep in mind that plastic parts are almost always very soft and very delicate, and in particular the sealing surfaces may not be damaged.

NOTE

Damage due to cold welding of the screws in the body!

- PFEIFFER recommends a heavy-duty grease paste (e.g. Gleitmo 805, manufacturer Fuchs) to prevent the cold-welding of the screws in the bodies.
- For high temperatures, PFEIFFER uses the heavy-duty grease paste Molykote 1000.
- ⇒ Do not use this product for ball valves with use of oxygen.
- ⇒ A suitable lubricant must be selected for grease-free ball valves, especially for use with oxygen.

3.5.1 Assembly of the horizontal 3-way ball valve BR 26l / BR 26t, DN 15 to 32 and NPS $\frac{1}{2}$ to 1 $\frac{1}{4}$

3.5.1.1 Pre-assembly of the body flanges (A and B)

- ⇒ Place the body flanges (2) with the flange side facing down on an even and clean work surface.

Seat ring soft seal version, not spring-loaded

- ⇒ Insert the seat ring (7) into the respective body chamber of the two body flanges (2).

Seat ring soft seal version, spring-loaded on all sides

- ⇒ Place the disc spring jacket (22) on the disc spring (21).

i Info

Pull on the disc spring jacket so that the long side of the jacket is positioned towards the body and the short side towards the seat ring. This ensures the sealing function.

- ⇒ Insert the jacketed disc spring (21) into the body chambers in the two body flanges (2).
- ⇒ Press the seat ring (7) up to the disc spring.

Seat ring soft seal version, OF spring-loaded

- ⇒ Insert the O-ring (20) into the respective body chamber of the two body flanges (2).
- ⇒ Press the seat ring (7) up to the O-ring (20).

Further assembly for all versions

- ⇒ Insert the sealing (9) into the corresponding recesses in the two body flanges (2).

3.5.1.2 Pre-assembly of the outlet flange (C)

- ⇒ Place the outlet flange (3) with the flange side facing down on an even and clean work surface.

Seat ring soft seal version, not spring-loaded

- ⇒ Insert the seat ring (7) into the respective body chamber of the outlet flange (3).

Seat ring soft seal version, spring-loaded on all sides

- ⇒ Place the disc spring jacket (22) on the disc spring (21).

i Info

Pull on the disc spring jacket so that the long side of the jacket is positioned towards the body and the short side towards the seat ring. This ensures the sealing function.

- ⇒ Insert the jacketed disc spring (21) into the body chambers in the outlet flange (3).
- ⇒ Press the seat ring (7) up to the disc spring.

Seat ring soft seal version, OF spring-loaded

- ⇒ Insert the O-ring (20) into the respective body chamber of the outlet flange (3).
- ⇒ Press the seat ring (7) up to the O-ring (20).

Further assembly for all versions

- ⇒ Insert the sealing (10) into the corresponding recesses in the outlet flange (3).

3.5.1.3 Assembly of the main body

- ⇒ Place the main body (1) on an even and clean work surface, so that the inside of the ball valve is easily to reach.
- ⇒ Screw the lightly greased stud bolts (15) into the main body (1).

i Info

– Depending on the version, stud bolts (15) with nuts (16) or screws (15) can be used.
– If screws are used, the above step is not necessary.

- ⇒ Press the bearing bush (12) at the appropriate location into the main body (1).
- ⇒ Push the control shaft (5) through the mounted bearing bush (12) into the main body. Make sure the control shaft can be moved.
- ⇒ Slightly rotate the V-ring packing (14) so it can be pushed over the mounted control shaft (5) more easily and insert it at the appropriate packing location into the main body (1). For the arrangement of the V-rings, see Fig. 3-2
- ⇒ Place the disc springs (13) onto the packing. For the arrangement of the disc springs, see Fig. 3-2.
- ⇒ Press the bearing bush (11) into the packing box flange (6).
- ⇒ Place the packing box flange (6) over the control shaft (5) on to the main body (1).
- ⇒ Lightly grease the screws (19).
- ⇒ Adjust the stuffing box flange with the screws (19).

i Info

Only tighten the screws hand-tight; final assembly is carried out in a later assembly step.

3.5.1.4 Assembly of the ball valve

- ⇒ To proceed with assembly turn the main body such that port (C) of the outlet flange faces upward, i.e. all three valve ports are easily accessible.
- ⇒ Insert the counter bearing (8) into the main body from the side.
- ⇒ Place the ball (4) onto the counter bearing and plug its recess onto the cam of the ready-assembled control shaft (5).
- ⇒ The outlet flange (3) (page C) pre-assembled in chapter 3.5.1.2 is placed on the main body (1) and adjusted with the lightly greased screws (17).

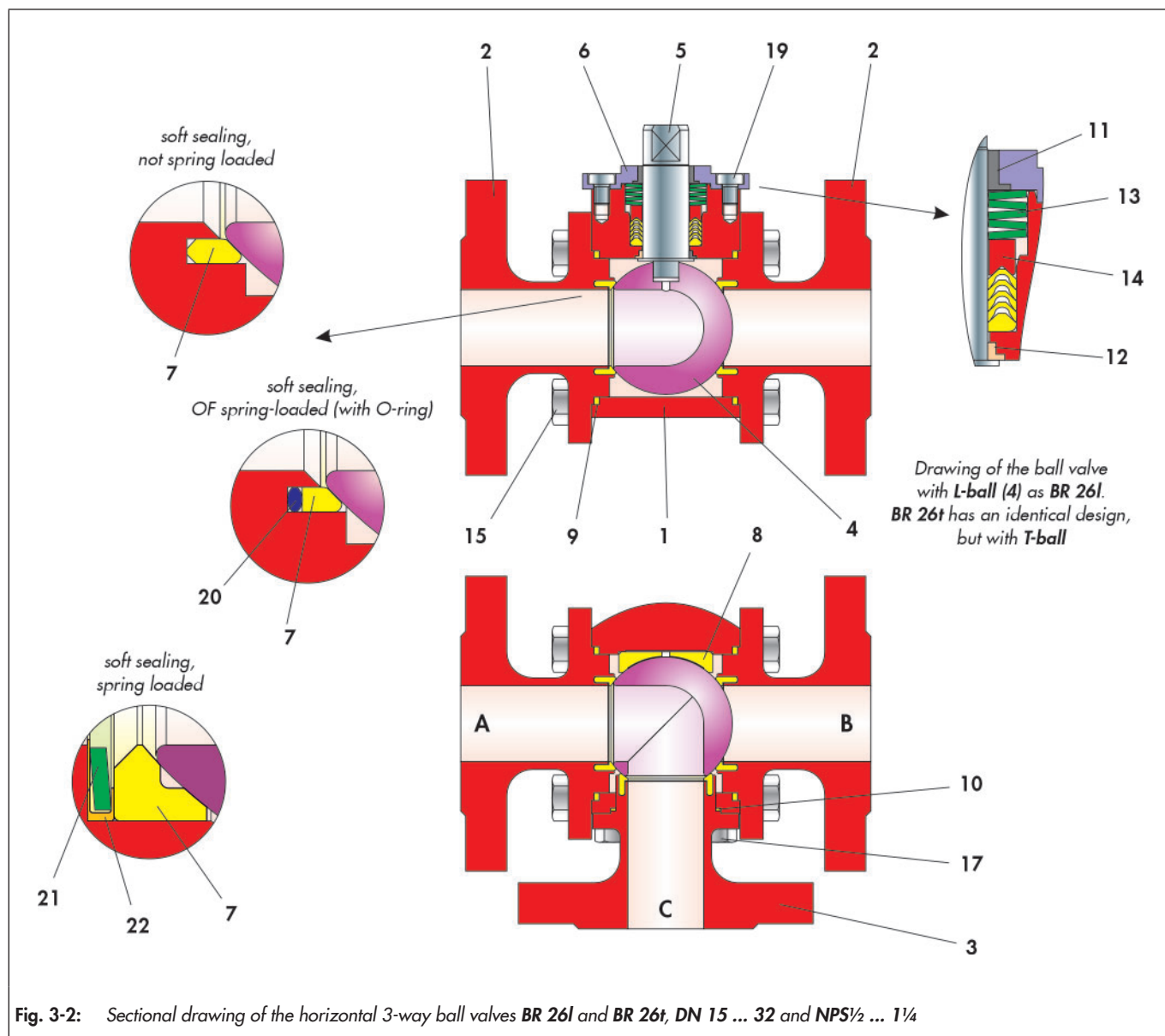

Fig. 3-2: Sectional drawing of the horizontal 3-way ball valves BR 26l and BR 26t, DN 15 ... 32 and NPS½ ... 1¼

Table 3-1: Parts list of the horizontal 3-way ball valves BR 26l and BR 26t, DN 15 ... 32 and NPS½ ... 1¼

Item	Description
1	Main body
2	Body flange
3	Outlet flange
4	Ball
5	Control flange
6	Stuffing box flange
7	Seat ring
8	Counter bearing
9	Sealing
10	Sealing
11	Bearing bush

Item	Description
12	Bearing bush
13	Disc spring set
14	V-ring packing
15 ¹⁾	Stud bolt / Screw
16 ¹⁾	Nut
17 ¹⁾	Stud bolt / Screw
18 ¹⁾	Nut
19	Screw
20	O-ring
21	Disc spring
22	Disc spring jacket

¹⁾ Depending on the nominal width, stud bolts can be fitted with nuts or screws.

i Info

- Depending on the version, stud bolts (17) with nuts (18) or screws (17) can be used.
- Only tighten the screws or nuts hand-tight; final assembly is carried out in a later assembly step.

The body flanges (2) pre-assembled in chapter 3.5.1.1 (side A and B) are placed on the main body (1) one after the other and adjusted with the nuts (16).

i Info

- Depending on the version, stud bolts (15) with nuts (16) or screws (15) can be used.
- Only tighten the screws or nuts hand-tight; final assembly is carried out in a later assembly step.

- ⇒ Properly align the body flanges (2), the outlet flange (3) as well as the packing box flange (6).
- ⇒ Tighten all nuts and bolts evenly in a criss-cross pattern.

i Info

- For permissible torque for tightening the body flanges and the stuffing box flange, see Table 15-1 and Table 15-3 in Chapter "15.1.1 Tightening torques".
- Prior to the leak test, the ball valve should be actuated a few times so that the ball can centre on the seat rings and provide an optimal seal.

3.5.2 Assembly of the horizontal 3-way ball valve BR 26l / BR 26t, DN 40 to 200 and NPS1½ to 8

3.5.2.1 Pre-assembly of the body flanges (A, B and C)

- ⇒ Place the body flanges (2) with the flange side facing down on an even and clean work surface.

Seat ring soft seal version, not spring-loaded

- ⇒ Insert the seat ring (7) into the respective body chamber of the three body flanges (2).

Seat ring soft seal version, spring-loaded on all sides

- ⇒ Place the disc spring jacket (22) on the disc spring (21).

i Info

Pull on the disc spring jacket so that the long side of the jacket is positioned towards the body and the short side towards the seat ring. This ensures the sealing function.

- ⇒ Insert the jacketed disc spring (21) into the body chambers in the three body flanges (2).
- ⇒ Press the seat ring (7) up to the disc spring.

Seat ring soft seal version, OF spring-loaded

- ⇒ Insert the O-ring (20) into the respective body chamber of the three body flanges (2).
- ⇒ Press the seat ring (7) up to the O-ring.

Further assembly for all versions

- ⇒ Insert the sealing (9) into the corresponding recesses in the three body flanges (2).

3.5.2.2 Assembly of the main body

- ⇒ Place the main body (1) on an even and clean work surface, so that the inside of the ball valve is easily to reach.
- ⇒ Screw the lightly greased stud bolts (15) into the main body (1).

i Info

- Depending on the version, stud bolts (15) with nuts (16) or screws (15) can be used.
- If screws are used, the above step is not necessary.

- ⇒ Press the lower bearing bush (28) into the main body (1). For the alignment of the bearing bush, see Fig. 3-3.
- ⇒ Lightly grease the trunnion of the ball (4).
- ⇒ Carefully insert the ball (4) into the main body. Insert the lower trunnion of the ball into the bearing bush (28) in the main body.

3.5.2.3 Pre-assembly of the packing bush

- ⇒ Push the bearing bush (12) with a slight rotary movement onto the control shaft (5).
- ⇒ Insert the control shaft (5) from the inside through the control shaft duct into the bonnet flange (23).

! NOTE

Damage due to improper assembly!

- ⇒ Do not damage the sealing surface of the control shaft (5).
- ⇒ Make sure that the bearing bush (12) and the control shaft (5) do not tilt when positioning in the Bonnet flange (23).

- ⇒ Slide the V-ring packing (14) over the mounted control shaft (5) with a slight rotating movement and insert it into the packing location of the Bonnet flange (23). For the arrangement of the V-rings, see Fig. 3-3.

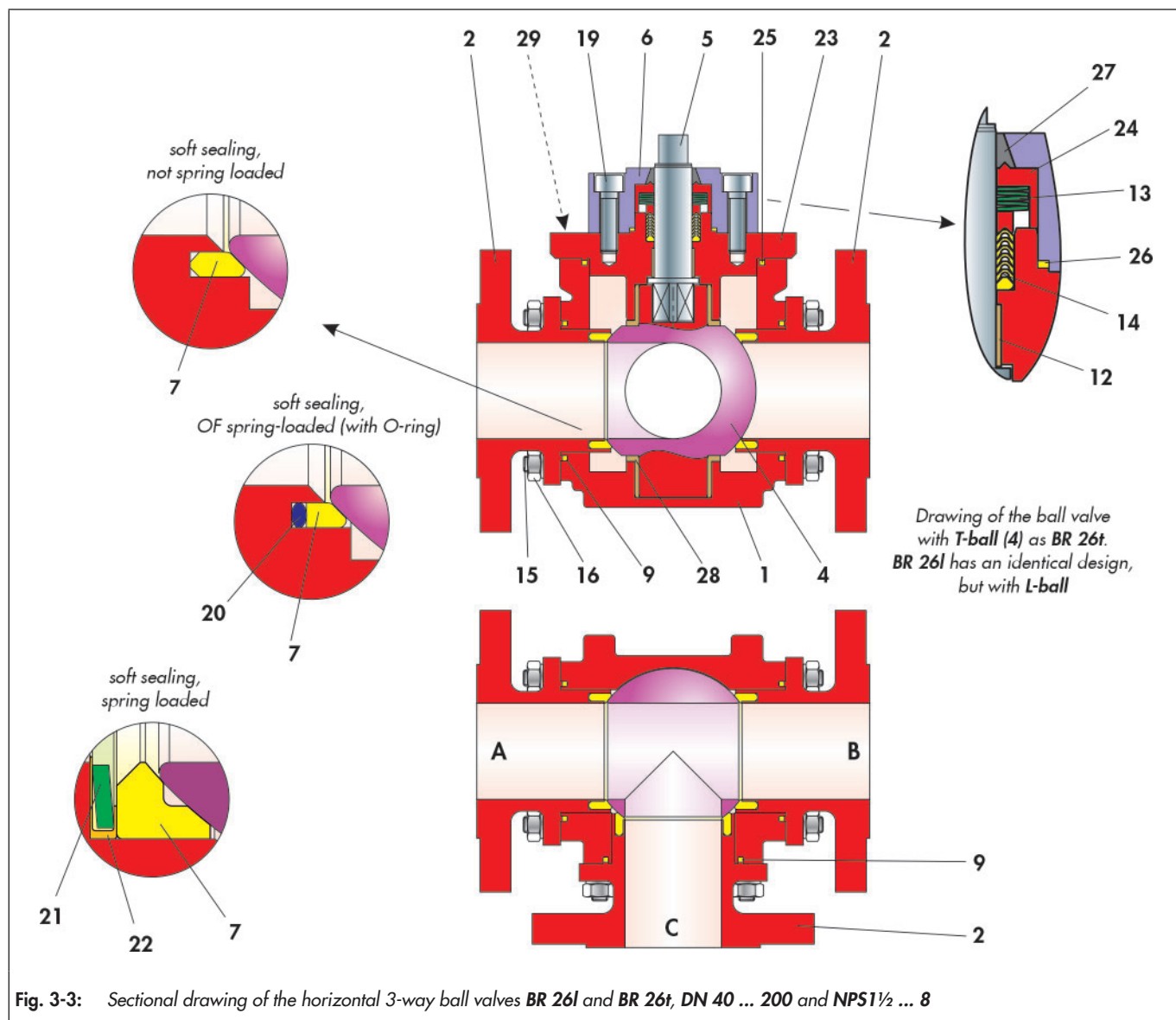

Fig. 3-3: Sectional drawing of the horizontal 3-way ball valves BR 26l and BR 26t, DN 40 ... 200 and NPS1½ ... 8

Table 3-2: Parts list of the horizontal 3-way ball valves BR 26l and BR 26t, DN 40 ... 200 and NPS1½ ... 8

Item	Description
1	Main body
2	Body flange
4	Ball
5	Control shaft
6	Stuffing box flange
7	Seat ring
9	Sealing
12	Bearing bush
13	Disc spring set
14	V-ring packing
15 ¹⁾	Stud bolt / Screw
16 ¹⁾	Nut

Item	Description
19	Screw
20	O-ring
21	Disc spring
22	Disc spring jacket
23	Bonnet flange
24	Bush
25	Ring
26	Ring
27	Ring
28	Bearing bush
29	Screw

¹⁾ Depending on the nominal width, stud bolts can be fitted with nuts or screws.

- ⇒ Place the disk spring set (13) over the control shaft (5) up to the V-ring packing (14). For the arrangement of the disk springs, see Fig. 3-3.
- ⇒ Place the bush (24) over the control shaft (5) up to the disk springs (13).
- ⇒ Press the ring (27) into the stuffing box flange (6).
- ⇒ Insert the O-ring (26) into the stuffing box flange (6).
- ⇒ Place the stuffing box flange (6) over the control shaft onto the bonnet flange (23).
- ⇒ Lightly grease the screws (19).
- ⇒ Adjust the stuffing box flange with the screws (19).

i Info

Only tighten the screws hand-tight; final assembly is carried out in a later assembly step.

3.5.2.4 Final assembly of the main body

- ⇒ Push the upper bearing bush (28) onto the trunnion of the ball (4) with a slight turning movement.
- ⇒ Insert the O-ring (25) into the main body (1).
- ⇒ Carefully place the pre-assembled bonnet flange (23) onto the main body (1).

! NOTE

- ⇒ Do not damage the O-ring (25).

- ⇒ Rotate the bonnet flange until the control shaft engages with the ball and the bonnet flange slides in the main body.
- ⇒ Rotate the bonnet flange (23) until the bores of both components are aligned with each other.
- ⇒ After applying grease to the screws (29) both parts are screwed together, evenly and in alternating pattern.

i Info

For permissible torque for tightening the connection of the bonnet flange can be found in Table 15-4 in Chapter "15.1.1 Tightening torques".

3.5.2.5 Assembly of the ball valve

- ⇒ Turn the main body for further installation so that all three mounting sides (A, B and C) are easily to reach.
- ⇒ The body flanges (2) pre-assembled in chapter 3.5.2.1 (side A, B and C) are placed on the main body (1) one after the other and adjusted with the nuts (16).

i Info

Depending on the version, stud bolts (15) with nuts (16) or screws (15) can be used.

i Info

Only tighten the screws or nuts hand-tight; final assembly is carried out in a later assembly step.

- ⇒ To complete the assembly, align the body flanges (2) and the stuffing box flange (6).
- ⇒ Tighten all screws or nuts evenly in alternating pattern.

i Info

- For permissible torque for tightening the body flanges and the stuffing box flange, see Table 15-1 and Table 15-3 in Chapter "15.1.1 Tightening torques".
- Prior to the leak test, the ball valve should be actuated a few times so that the ball can centre on the seat rings and provide an optimal seal.

3.5.3 Assembly of the vertical 3-way ball valve BR 26v, DN 15 to 32 and NPS $\frac{1}{2}$ to 1 $\frac{1}{4}$

3.5.3.1 Pre-assembly of the body flanges (A and B)

- ⇒ Place the body flanges (2) with the flange side facing down on an even and clean work surface.

Seat ring soft seal version, not spring-loaded

- ⇒ Insert the seat ring (7) into the respective body chamber of the two body flanges (2).

Seat ring soft seal version, spring-loaded on all sides

- ⇒ Place the disc spring jacket (22) on the disc spring (21).

i Info

Pull on the disc spring jacket so that the long side of the jacket is positioned towards the body and the short side towards the seat ring. This ensures the sealing function.

- ⇒ Insert the jacketed disc spring (21) into the body chambers in the two body flanges (2).
- ⇒ Press the seat ring (7) up to the disc spring.

Seat ring soft seal version, OF spring-loaded

- ⇒ Insert the O-ring (20) into the respective body chamber of the two body flanges (2).
- ⇒ Press the seat ring (7) up to the O-ring (20).

Further assembly for all versions

- ⇒ Insert the sealing (9) into the corresponding recesses in the two body flanges (2).

3.5.3.2 Pre-assembly of the outlet flange (C)

- ⇒ Place the outlet flange (3) with the flange side facing down on an even and clean work surface.

Seat ring soft seal version, not spring-loaded

- ⇒ Insert the seat ring (7) into the respective body chamber of the outlet flange (3).

Seat ring soft seal version, spring-loaded on all sides

- ⇒ Place the disc spring jacket (22) on the disc spring (21).

i Info

Pull on the disc spring jacket so that the long side of the jacket is positioned towards the body and the short side towards the seat ring. This ensures the sealing function.

- ⇒ Insert the jacketed disc spring (21) into the body chambers in the outlet flange (3).
- ⇒ Press the seat ring (7) up to the disc spring.

Seat ring soft seal version, OF spring-loaded

- ⇒ Insert the O-ring (20) into the respective body chamber of the outlet flange (3).
- ⇒ Press the seat ring (7) up to the O-ring (20).

Further assembly for all versions

- ⇒ Insert the sealing (10) into the corresponding recesses in the outlet flange (3).

3.5.3.3 Assembly of the main body

- ⇒ Place the main body (1) on an even and clean work surface, so that the inside of the ball valve is easily to reach.
- ⇒ Screw the lightly greased stud bolts (15) into the main body (1).

i Info

*– Depending on the version, stud bolts (15) with nuts (16) or screws (15) can be used.
– If screws are used, the above step is not necessary.*

- ⇒ Press the bearing bush (12) at the appropriate location into the main body (1).
- ⇒ Push the control shaft (5) through the mounted bearing bush (12) into the main body. Make sure the control shaft can be moved.

- ⇒ Slightly rotate the V-ring packing (14) so it can be pushed over the mounted control shaft (5) more easily and insert it at the appropriate packing location into the main body (1). For the arrangement of the V-rings, see Fig. 3-4
- ⇒ Place the disc springs (13) onto the packing. For the arrangement of the disc springs, see Fig. 3-4.
- ⇒ Press the bearing bush (11) into the packing box flange (6).
- ⇒ Place the packing box flange (6) over the control shaft (5) onto the main body (1).
- ⇒ Lightly grease the screws (19).
- ⇒ Adjust the stuffing box flange with the screws (19).

i Info

Only tighten the screws hand-tight; final assembly is carried out in a later assembly step.

3.5.3.4 Assembly of the ball valve

- ⇒ To proceed with assembly turn the main body such that port (C) of the outlet flange faces upward, i.e. all three valve ports are easily accessible.
- ⇒ Place the ball (4) in the main body and push it with the groove onto the cam of the mounted control shaft (5).
- ⇒ The outlet flange (3) (page C) pre-assembled in chapter 3.5.3.2 is placed on the main body (1) and adjusted with the lightly greased screws (17).

i Info

*– Depending on the version, stud bolts (17) with nuts (18) or screws (17) can be used.
– Only tighten the screws or nuts hand-tight; final assembly is carried out in a later assembly step.*

The body flanges (2) pre-assembled in chapter 3.5.3.1 (side A and B) are placed on the main body (1) one after the other and adjusted with the nuts (16).

i Info

*– Depending on the version, stud bolts (15) with nuts (16) or screws (15) can be used.
– Only tighten the screws or nuts hand-tight; final assembly is carried out in a later assembly step.*

- ⇒ Properly align the body flanges (2), the outlet flange (3) as well as the packing box flange (6).
- ⇒ Tighten all nuts and bolts evenly in a criss-cross pattern.

! NOTE

Damage due to improper assembly!

When tightening the screw connections, ensure that the ball moves smoothly.

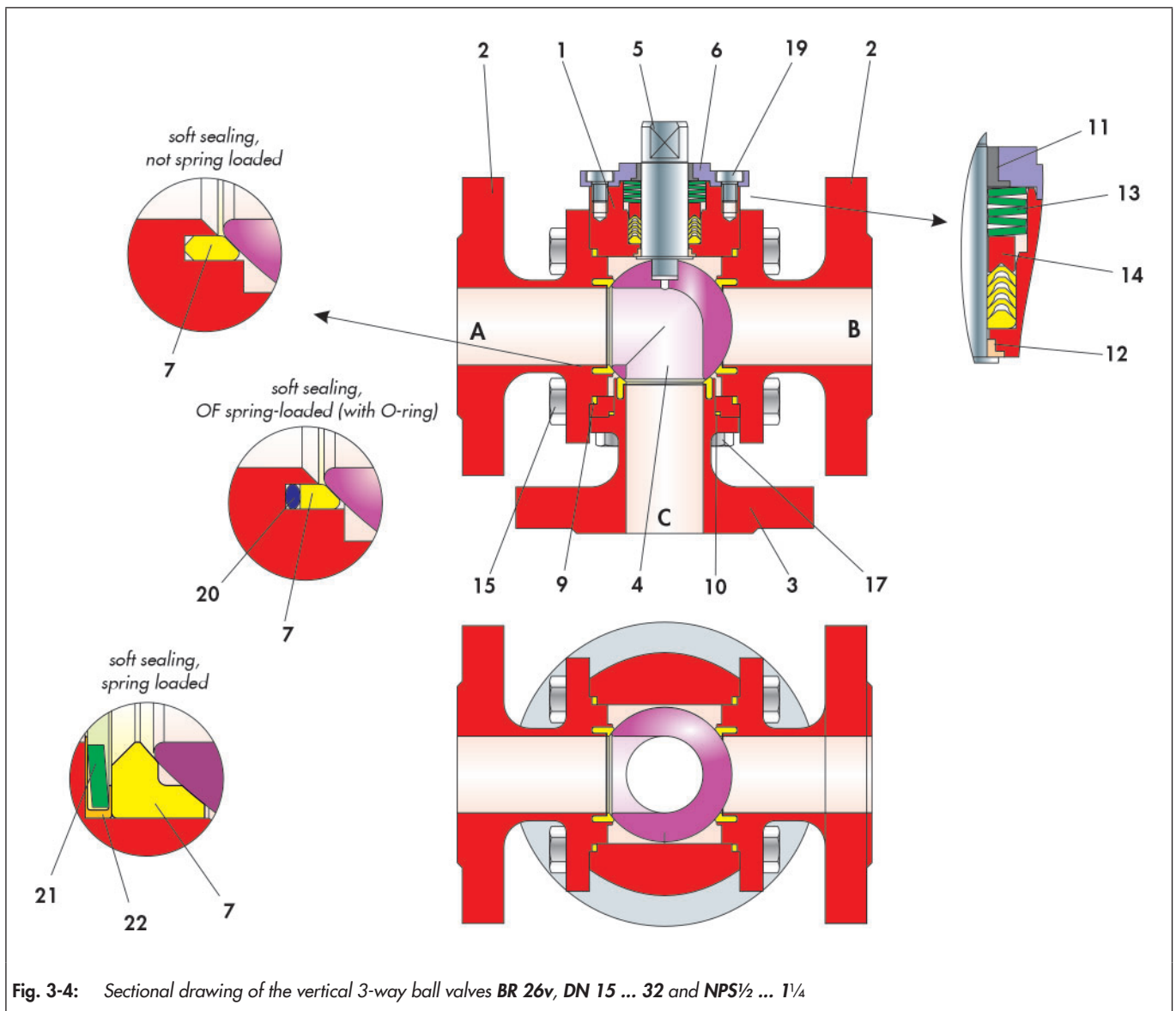

Table 3-3: Parts list of the vertical 3-way ball valves BR 26v, DN 15 ... 32 and NPS 1/2 ... 1 1/4

Item	Description	Item	Description
1	Main body	13	Disc spring set
2	Body flange	14	V-ring packing
3	Outlet flange	15 ¹⁾	Stud bolt / Screw
4	Ball	16 ¹⁾	Nut
5	Control shaft	17 ¹⁾	Stud bolt / Screw
6	Stuffing box flange	18 ¹⁾	Nut
7	Seat ring	19	Screw
9	Sealing	20	O-ring
10	Sealing	21	Disc spring
11	Bearing bush	22	Disc spring jacket
12	Bearing bush		

¹⁾ Depending on the nominal width, stud bolts can be fitted with nuts or screws.

i Info

- For permissible torque for tightening the body flanges and the stuffing box flange, see Table 15-1 and Table 15-3 in Chapter “15.1.1 Tightening torques”.
- Prior to the leak test, the ball valve should be actuated a few times so that the ball can centre on the seat rings and provide an optimal seal.

3.5.4 Assembly of the vertical 3-way ball valve BR 26v, DN 40 to 200 and NPS1½ to 8

3.5.4.1 Pre-assembly of the body flanges (A and B)

- ⇒ Place the body flanges (2) with the flange side facing down on an even and clean work surface.

Seat ring soft seal version, not spring-loaded

- ⇒ Insert the seat ring (7) into the respective body chamber of the two body flanges (2).

Seat ring soft seal version, spring-loaded on all sides

- ⇒ Place the disc spring jacket (22) on the disc spring (21).

i Info

Pull on the disc spring jacket so that the long side of the jacket is positioned towards the body and the short side towards the seat ring. This ensures the sealing function.

- ⇒ Insert the jacketed disc spring (21) into the body chambers in the two body flanges (2).
- ⇒ Press the seat ring (7) up to the disc spring.

Seat ring soft seal version, OF spring-loaded

- ⇒ Insert the O-ring (20) into the respective body chamber of the two body flanges (2).
- ⇒ Press the seat ring (7) up to the O-ring (20).

Further assembly for all versions

- ⇒ Insert the sealing (9) into the corresponding recesses in the two body flanges (2).

3.5.4.2 Pre-assembly of the body flange (C)

- ⇒ Place the body flanges (2) with the flange side facing down on an even and clean work surface.
- ⇒ Insert the bearing ring (30) into the body chamber of the body flange (2).

- ⇒ Insert the sealing (9) into the corresponding recesses in the body flange (2).

3.5.4.3 Assembly of the main body

- ⇒ Place the main body (1) on an even and clean work surface, so that the inside of the ball valve is easily to reach.
- ⇒ Screw the lightly greased stud bolts (15) into the main body (1).

i Info

- Depending on the version, stud bolts (15) with nuts (16) or screws (15) can be used.
- If screws are used, the above step is not necessary.

3.5.4.4 Pre-assembly of the packing bush

- ⇒ Push the bearing bush (12) with a slight rotary movement onto the control shaft (5).
- ⇒ Insert the control shaft (5) from the inside through the control shaft duct into the bonnet flange (23).

! NOTE

Damage due to improper assembly!

- ⇒ Do not damage the sealing surface of the control shaft (5).
- ⇒ Make sure that the bearing bush (12) and the control shaft (5) do not tilt when positioning in the Bonnet flange (23).

- ⇒ Slide the V-ring packing (14) over the mounted control shaft (5) with a slight rotating movement and insert it into the packing location of the Bonnet flange (23). For the arrangement of the V-rings, see Fig. 3-5.
- ⇒ Place the disk spring set (13) over the control shaft (5) up to the V-ring packing (14). For the arrangement of the disk springs, see Fig. 3-5.
- ⇒ Place the bush (24) over the control shaft (5) up to the disk springs (13).
- ⇒ Press the ring (27) into the stuffing box flange (6).
- ⇒ Insert the O-ring (26) into the stuffing box flange (6).
- ⇒ Place the stuffing box flange (6) over the control shaft onto the bonnet flange (23).
- ⇒ Lightly grease the screws (19).
- ⇒ Adjust the stuffing box flange with the screws (19).

i Info

Only tighten the screws hand-tight; final assembly is carried out in a later assembly step.

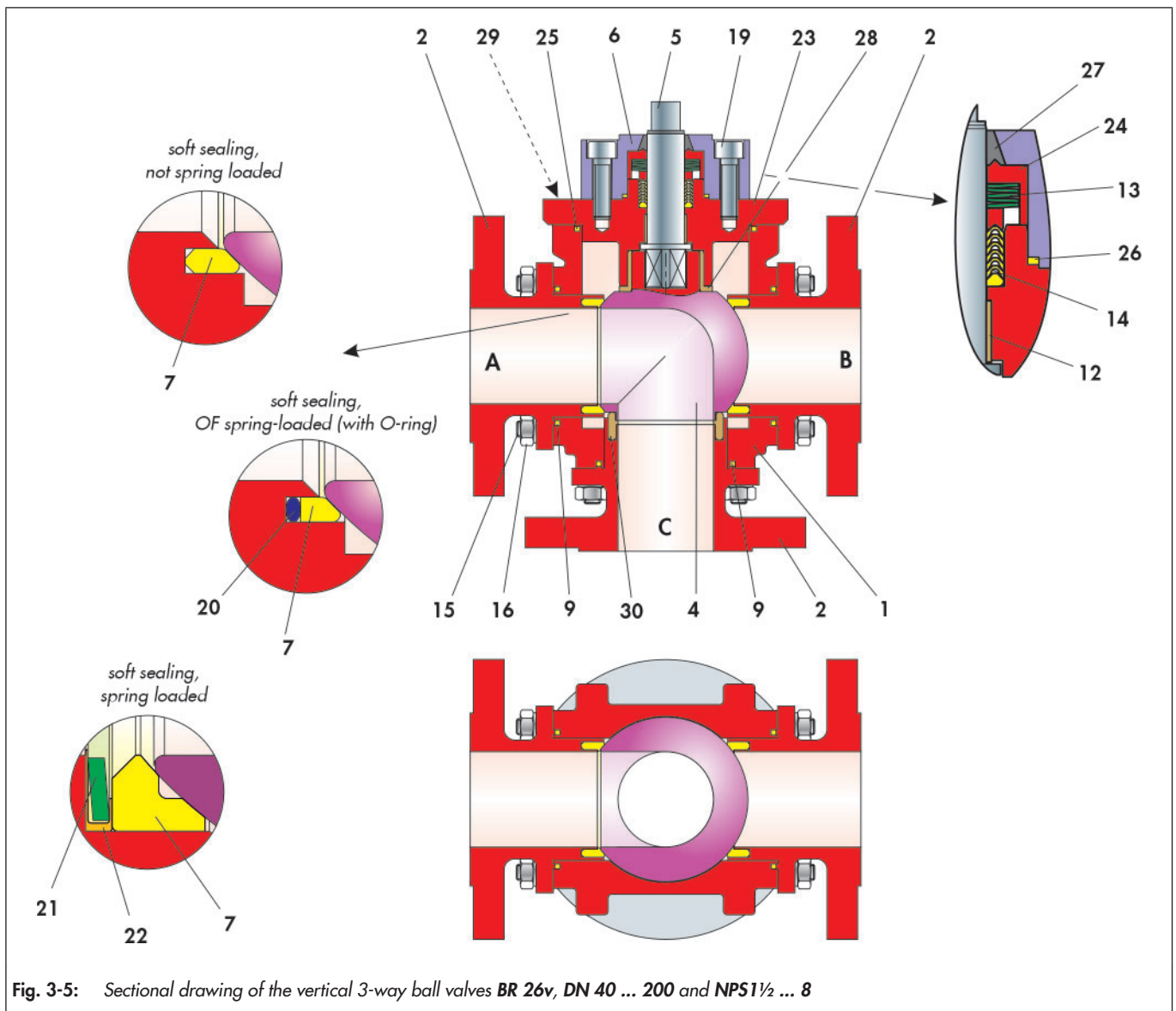

Fig. 3-5: Sectional drawing of the vertical 3-way ball valves BR 26v, DN 40 ... 200 and NPS1½ ... 8

Table 3-4: Parts list of the vertical 3-way ball valves BR 26v, DN 40 ... 200 and NPS1½ ... 8

Item	Description	Item	Description
1	Main body	19	Screw
2	Body flange	20	O-ring
4	Ball	21	Disc spring
5	Control shaft	22	Disc spring jacket
6	Stuffing box flange	23	Bonnet flange
7	Seat ring	24	Bush
9	Sealing	25	Ring
12	Bearing bush	26	Ring
13	Disc spring set	27	Ring
14	V-ring packing	28	Bearing bush
15 ¹⁾	Stud bolt / Screw	29	Screw
16 ¹⁾	Nut	30	Bearing ring

¹⁾ Depending on the nominal width, stud bolts can be fitted with nuts or screws.

3.5.4.5 Final assembly of the main body

The body flange (2) (page C) pre-assembled in chapter 3.5.4.2 is attached to the main body (1) and adjusted with the nuts (16).

i Info

- Depending on the version, stud bolts (15) with nuts (16) or screws (15) can be used.
- Only tighten the screws hand-tight; final assembly is carried out in a later assembly step.

- ⇒ Lightly grease the bearing surface of the ball (4).
- ⇒ Carefully insert the ball (4) into the main body. Center the bearing surface of the ball on the bearing ring (30) in the body flange.
- ⇒ Push the upper bearing bush (28) onto the trunnion of the ball (4) with a slight turning movement.
- ⇒ Insert the O-ring (25) into the main body (1).
- ⇒ Carefully place the pre-assembled bonnet flange (23) onto the main body (1).

! NOTE

- ⇒ Do not damage the O-ring (25).

- ⇒ Rotate the bonnet flange until the control shaft engages with the ball and the bonnet flange slides in the main body.
- ⇒ Rotate the bonnet flange (23) until the bores of both components are aligned with each other.
- ⇒ After applying grease to the screws (29) both parts are screwed together, evenly and in alternating pattern.

i Info

For permissible torque for tightening the connection of the bonnet flange can be found in Table 15-4 in Chapter "15.1.1 Tightening torques".

3.5.4.6 Assembly of the ball valve

- ⇒ Turn the main body for further installation so that the two mounting sides (A and B) are easy to reach.
- ⇒ The body flanges (2) pre-assembled in chapter 3.5.4.1 (side A and B) are placed on the main body (1) one after the other and adjusted with the nuts (16).

i Info

- Depending on the version, stud bolts (15) with nuts (16) or screws (15) can be used.
- Only tighten the screws or nuts hand-tight; final assembly is carried out in a later assembly step.

- ⇒ To complete the assembly, align the body flanges (2) and the stuffing box flange (6).
- ⇒ Tighten all screws or nuts evenly in alternating pattern.

i Info

- For permissible torque for tightening the body flanges and the stuffing box flange, see Table 15-1 and Table 15-3 in Chapter "15.1.1 Tightening torques".
- Prior to the leak test, the ball valve should be actuated a few times so that the ball can centre on the seat rings and provide an optimal seal.

3.5.5 Assembly of the horizontal 4-way ball valve BR 26x, DN 15 to 32 and NPS $\frac{1}{2}$ to 1 $\frac{1}{4}$

3.5.5.1 Pre-assembly of the body flanges (A and B)

- ⇒ Place the body flanges (2) with the flange side facing down on an even and clean work surface.

Seat ring soft seal version, not spring-loaded

- ⇒ Insert the seat ring (7) into the respective body chamber of the two body flanges (2).

Seat ring soft seal version, spring-loaded on all sides

- ⇒ Place the disc spring jacket (22) on the disc spring (21).

i Info

Pull on the disc spring jacket so that the long side of the jacket is positioned towards the body and the short side towards the seat ring. This ensures the sealing function.

- ⇒ Insert the jacketed disc spring (21) into the body chambers in the two body flanges (2).
- ⇒ Press the seat ring (7) up to the disc spring.

Seat ring soft seal version, OF spring-loaded

- ⇒ Insert the O-ring (20) into the respective body chamber of the two body flanges (2).
- ⇒ Press the seat ring (7) up to the O-ring (20).

Further assembly for all versions

- ⇒ Insert the sealing (9) into the corresponding recesses in the two body flanges (2).

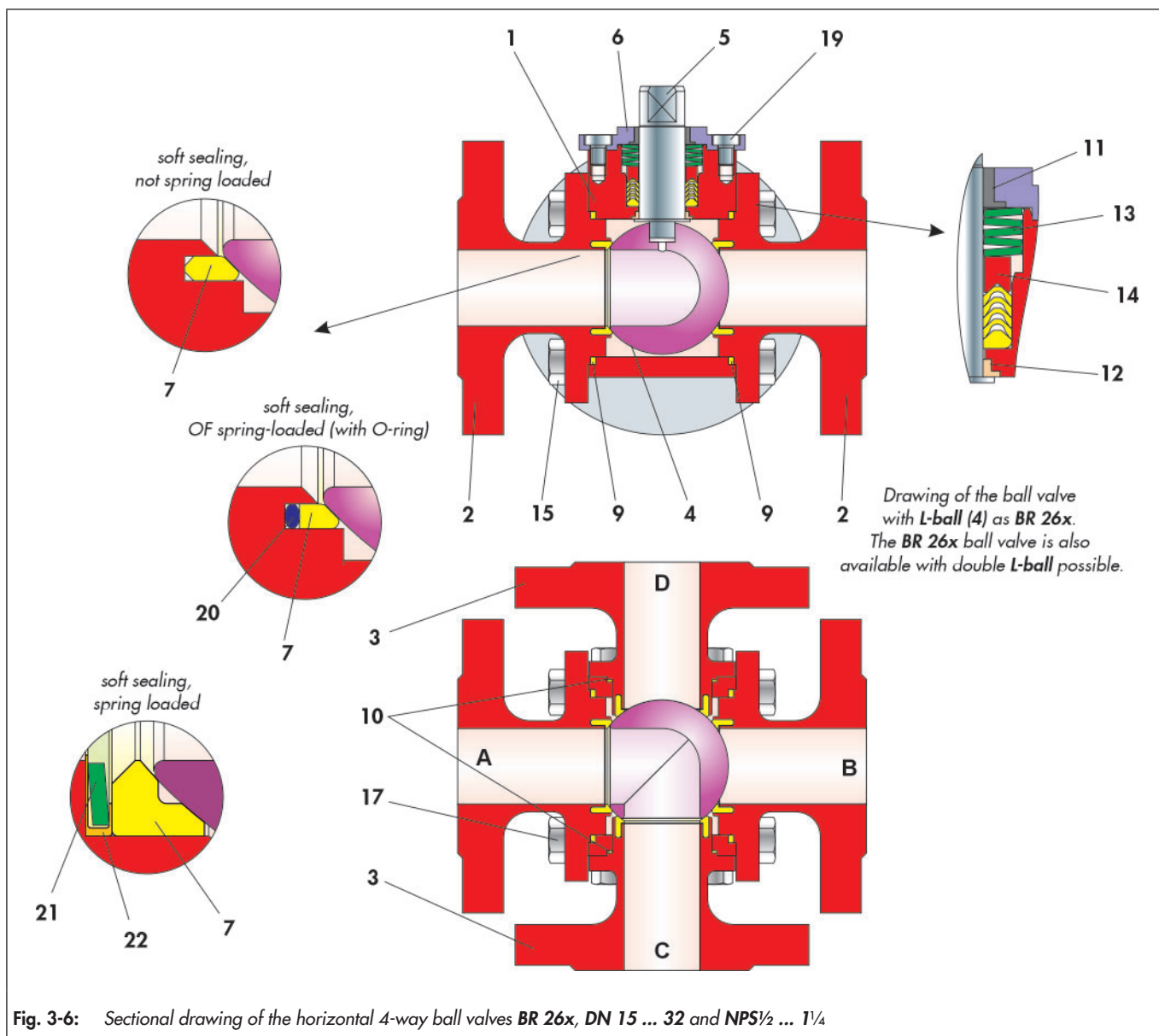

Fig. 3-6: Sectional drawing of the horizontal 4-way ball valves BR 26x, DN 15 ... 32 and NPS½ ... 1¼

Table 3-5: Parts list of the horizontal 4-way ball valves BR 26x, DN 15 ... 32 and NPS½ ... 1¼

Item	Description
1	Main body
2	Body flange
3	Outlet flange
4	Ball
5	Control shaft
6	Stuffing box flange
7	Seat ring
9	Sealing
10	Sealing
11	Bearing bush
12	Bearing bush

Item	Description
13	Disc spring set
14	V-ring packing
15 ¹⁾	Stud bolt / Screw
16 ¹⁾	Nut
17 ¹⁾	Stud bolt / Screw
18 ¹⁾	Nut
19	Screw
20	O-ring
21	Disc spring
22	Disc spring jacket

¹⁾ Depending on the nominal width, stud bolts can be fitted with nuts or screws.

3.5.5.2 Pre-assembly of the outlet flanges (C and D)

- ⇒ Place both outlet flanges (3) with the flange side facing down on an even and clean work surface.

Seat ring soft seal version, not spring-loaded

- ⇒ Insert the seat ring (7) into the respective body chamber of the two outlet flanges (3).

Seat ring soft seal version, spring-loaded on all sides

- ⇒ Place the disc spring jacket (22) on the disc spring (21).

i Info

Pull on the disc spring jacket so that the long side of the jacket is positioned towards the body and the short side towards the seat ring. This ensures the sealing function.

- ⇒ Insert the jacketed disc spring (21) into the body chambers in the two outlet flanges (3).
- ⇒ Press the seat ring (7) up to the disc spring.

Seat ring soft seal version, OF spring-loaded

- ⇒ Insert the O-ring (20) into the respective body chamber of the two outlet flanges (3).
- ⇒ Press the seat ring (7) up to the O-ring (20).

Further assembly for all versions

- ⇒ Insert the sealing (10) into the corresponding recesses in the two outlets flange (3).

3.5.5.3 Assembly of the main body

- ⇒ Place the main body (1) on an even and clean work surface, so that the inside of the ball valve is easy to reach.
- ⇒ Screw the lightly greased stud bolts (15) into the main body (1).

i Info

*– Depending on the version, stud bolts (15) with nuts (16) or screws (15) can be used.
– If screws are used, the above step is not necessary.*

- ⇒ Press the bearing bush (12) at the appropriate location into the main body (1).
- ⇒ Push the control shaft (5) through the mounted bearing bush (12) into the main body. Make sure the control shaft can be moved.
- ⇒ Slightly rotate the V-ring packing (14) so it can be pushed over the mounted control shaft (5) more easily and insert it at the appropriate packing location into the main body (1). For the arrangement of the V-rings, see Fig. 3-6

- ⇒ Place the disc springs (13) onto the packing. For the arrangement of the disc springs, see Fig. 3-6.
- ⇒ Press the bearing bush (11) into the packing box flange (6).
- ⇒ Place the packing box flange (6) over the control shaft (5) onto the main body (1).
- ⇒ Lightly grease the screws (19).
- ⇒ Adjust the stuffing box flange with the screws (19).

i Info

Only tighten the screws hand-tight; final assembly is carried out in a later assembly step.

3.5.5.4 Assembly of the ball valve

- ⇒ To proceed with assembly turn the main body such that all four valve ports are easy to reach.
- ⇒ Place the ball (4) in the main body and push it with the groove onto the cam of the mounted control shaft (5).
- ⇒ The outlet flanges (3) (page C and D) pre-assembled in chapter 3.5.5.2 are placed on the main body (1) and adjusted with the lightly greased screws (17).

i Info

*– Depending on the version, stud bolts (17) with nuts (18) or screws (17) can be used.
– Only tighten the screws or nuts hand-tight; final assembly is carried out in a later assembly step.*

The body flanges (2) pre-assembled in chapter 3.5.5.1 (side A and B) are placed on the main body (1) one after the other and adjusted with the nuts (16).

i Info

*– Depending on the version, stud bolts (15) with nuts (16) or screws (15) can be used.
– Only tighten the screws or nuts hand-tight; final assembly is carried out in a later assembly step.*

- ⇒ Properly align the body flanges (2), the outlet flanges (3) as well as the packing box flange (6).
- ⇒ Tighten all nuts and bolts evenly in a criss-cross pattern.

i Info

*– For permissible torque for tightening the body flanges and the stuffing box flange, see Table 15-1 and Table 15-3 in Chapter "15.1.1 Tightening torques".
– Prior to the leak test, the ball valve should be actuated a few times so that the ball can centre on the seat rings and provide an optimal seal.*

3.5.6 Assembly of the horizontal 4-way ball valve BR 26x, DN 40 to 200 and NPS1½ to 8

3.5.6.1 Pre-assembly of the body flanges (A, B C and D)

- ⇒ Place the body flanges (2) with the flange side facing down on an even and clean work surface.

Seat ring soft seal version, not spring-loaded

- ⇒ Insert the seat ring (7) into the respective body chamber of the four body flanges (2).

Seat ring soft seal version, spring-loaded on all sides

- ⇒ Place the disc spring jacket (22) on the disc spring (21).

i Info

Pull on the disc spring jacket so that the long side of the jacket is positioned towards the body and the short side towards the seat ring. This ensures the sealing function.

- ⇒ Insert the jacketed disc spring (21) into the body chambers in the four body flanges (2).
- ⇒ Press the seat ring (7) up to the disc spring.

Seat ring soft seal version, OF spring-loaded

- ⇒ Insert the O-ring (20) into the respective body chamber of the four body flanges (2).
- ⇒ Press the seat ring (7) up to the O-ring.

Further assembly for all versions

- ⇒ Insert the sealing (9) into the corresponding recesses in the four body flanges (2).

3.5.6.2 Assembly of the main body

- ⇒ Place the main body (1) on an even and clean work surface, so that the inside of the ball valve is easy to reach.
- ⇒ Screw the lightly greased stud bolts (15) into the main body (1).

i Info

– Depending on the version, stud bolts (15) with nuts (16) or screws (15) can be used.
– If screws are used, the above step is not necessary.

- ⇒ Press the lower bearing bush (28) into the main body (1). For the alignment of the bearing bush, see Fig. 3-7.
- ⇒ Lightly grease the trunnion of the ball (4).

- ⇒ Carefully insert the ball (4) into the main body. Insert the lower trunnion of the ball into the bearing bush (28) in the main body.

3.5.6.3 Pre-assembly of the bonnet flange

- ⇒ Push the bearing bush (12) with a slight rotary movement onto the control shaft (5).
- ⇒ Insert the control shaft (5) from the inside through the control shaft duct into the bonnet flange (23).

! NOTE

Damage due to improper assembly!

- ⇒ Do not damage the sealing surface of the control shaft (5).
- ⇒ Make sure that the bearing bush (12) and the control shaft (5) do not tilt when positioning in the Bonnet flange (23).

- ⇒ Slide the V-ring packing (14) over the mounted control shaft (5) with a slight rotating movement and insert it into the packing location of the bonnet flange (23). For the arrangement of the V-rings, see Fig. 3-7.
- ⇒ Place the disk spring set (13) over the control shaft (5) up to the V-ring packing (14). For the arrangement of the disk springs, see Fig. 3-7.
- ⇒ Place the bush (24) over the control shaft (5) up to the disk springs (13).
- ⇒ Press the ring (27) into the stuffing box flange (6).
- ⇒ Insert the O-ring (26) into the stuffing box flange (6).
- ⇒ Place the stuffing box flange (6) over the control shaft onto the bonnet flange (23).
- ⇒ Lightly grease the screws (19).
- ⇒ Adjust the stuffing box flange with the screws (19).

i Info

Only tighten the screws hand-tight; final assembly is carried out in a later assembly step.

3.5.6.4 Final assembly of the main body

- ⇒ Push the upper bearing bush (28) onto the trunnion of the ball (4) with a slight turning movement.
- ⇒ Insert the O-ring (25) into the main body (1).
- ⇒ Carefully place the pre-assembled bonnet flange (23) onto the main body (1).

! NOTE

- ⇒ Do not damage the O-ring (25).

- ⇒ Rotate the bonnet flange until the control shaft engages with the ball and the bonnet flange slides in the main body.

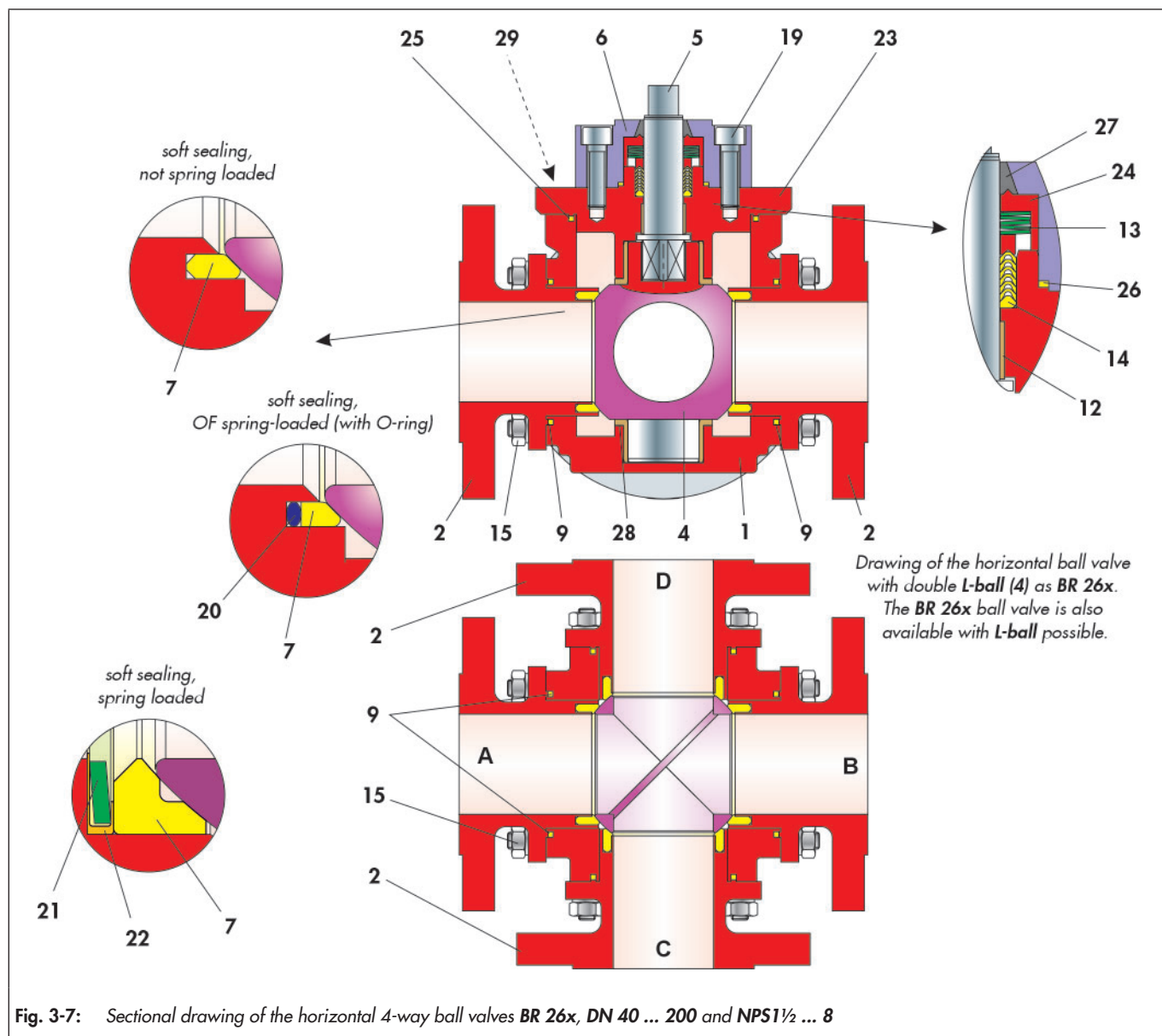

Table 3-6: Parts list of the horizontal 4-way ball valves BR 26x, DN 40 ... 200 and NPS1½ ... 8

Item	Description
1	Main body
2	Body flange
4	Ball
5	Control shaft
6	Stuffing box flange
7	Seat ring
9	Sealing
12	Bearing bush
13	Disc spring set
14	V-ring packing
15 ¹⁾	Stud bolt / Screw
16 ¹⁾	Nut

Item	Description
19	Screw
20	O-ring
21	Disc spring
22	Disc spring jacket
23	Bonnet flange
24	Bush
25	Ring
26	Ring
27	Ring
28	Bearing bush
29	Screw

¹⁾ Depending on the nominal width, stud bolts can be fitted with nuts or screws.

- ⇒ Rotate the bonnet flange (23) until the bores of both components are aligned with each other.
- ⇒ After applying grease to the screws (29) both parts are screwed together, evenly and in alternating pattern.

i Info

For permissible torque for tightening the connection of the bonnet flange can be found in Table 15-4 in Chapter "15.1.1 Tightening torques".

3.5.6.5 Assembly of the ball valve

- ⇒ Turn the main body for further installation so that all four mounting sides (A, B, C and D) are easy to reach.
- ⇒ The body's flanges (2) pre-assembled in chapter 3.5.2.1 (side A, B, C and D) are placed on the main body (1) one after the other and adjusted with the nuts (16).

i Info

- Depending on the version, stud bolts (15) with nuts (16) or screws (15) can be used.
- Only tighten the screws or nuts hand-tight; final assembly is carried out in a later assembly step.

- ⇒ To complete the assembly, align the body flanges (2) and the stuffing box flange (6).
- ⇒ Tighten all screws or nuts evenly in alternating pattern.

i Info

- For permissible torque for tightening the body flanges and the stuffing box flange, see Table 15-1 and Table 15-3 in Chapter "15.1.1 Tightening torques".
- Prior to the leak test, the ball valve should be actuated a few times so that the ball can centre on the seat rings and provide an optimal seal.

3.5.7 Assembly of the 5/4-way ball valve BR 26x, DN 25 to 32 and NPS1 to 1¼

3.5.7.1 Pre-assembly of the body flanges (A and B)

- ⇒ Place the body flanges (2) with the flange side facing down on an even and clean work surface.

Seat ring soft seal version, not spring-loaded

- ⇒ Insert the seat ring (7) into the respective body chamber of the two body flanges (2).

Seat ring soft seal version, spring-loaded on all sides

- ⇒ Place the disc spring jacket (22) on the disc spring (21).

i Info

Pull on the disc spring jacket so that the long side of the jacket is positioned towards the body and the short side towards the seat ring. This ensures the sealing function.

- ⇒ Insert the jacketed disc spring (21) into the body chambers in the two body flanges (2).
- ⇒ Press the seat ring (7) up to the disc spring.

Seat ring soft seal version, OF spring-loaded

- ⇒ Insert the O-ring (20) into the respective body chamber of the two body flanges (2).
- ⇒ Press the seat ring (7) up to the O-ring (20).

Further assembly for all versions

- ⇒ Insert the sealing (9) into the corresponding recesses in the two body flanges (2).

3.5.7.2 Pre-assembly of the outlet flanges (C, D and E)

- ⇒ Place both outlet flanges (3) with the flange side facing down on an even and clean work surface.

Seat ring soft seal version, not spring-loaded

- ⇒ Insert the seat ring (7) into the respective body chamber of the three outlet flanges (3).

Seat ring soft seal version, spring-loaded on all sides

- ⇒ Place the disc spring jacket (22) on the disc spring (21).

i Info

Pull on the disc spring jacket so that the long side of the jacket is positioned towards the body and the short side towards the seat ring. This ensures the sealing function.

- ⇒ Insert the jacketed disc spring (21) into the body chambers in the three outlet flanges (3).
- ⇒ Press the seat ring (7) up to the disc spring.

Seat ring soft seal version, OF spring-loaded

- ⇒ Insert the O-ring (20) into the respective body chamber of the three outlet flanges (3).
- ⇒ Press the seat ring (7) up to the O-ring (20).

Further assembly for all versions

- ⇒ Insert the sealing (10) into the corresponding recesses in the three outlets flange (3).

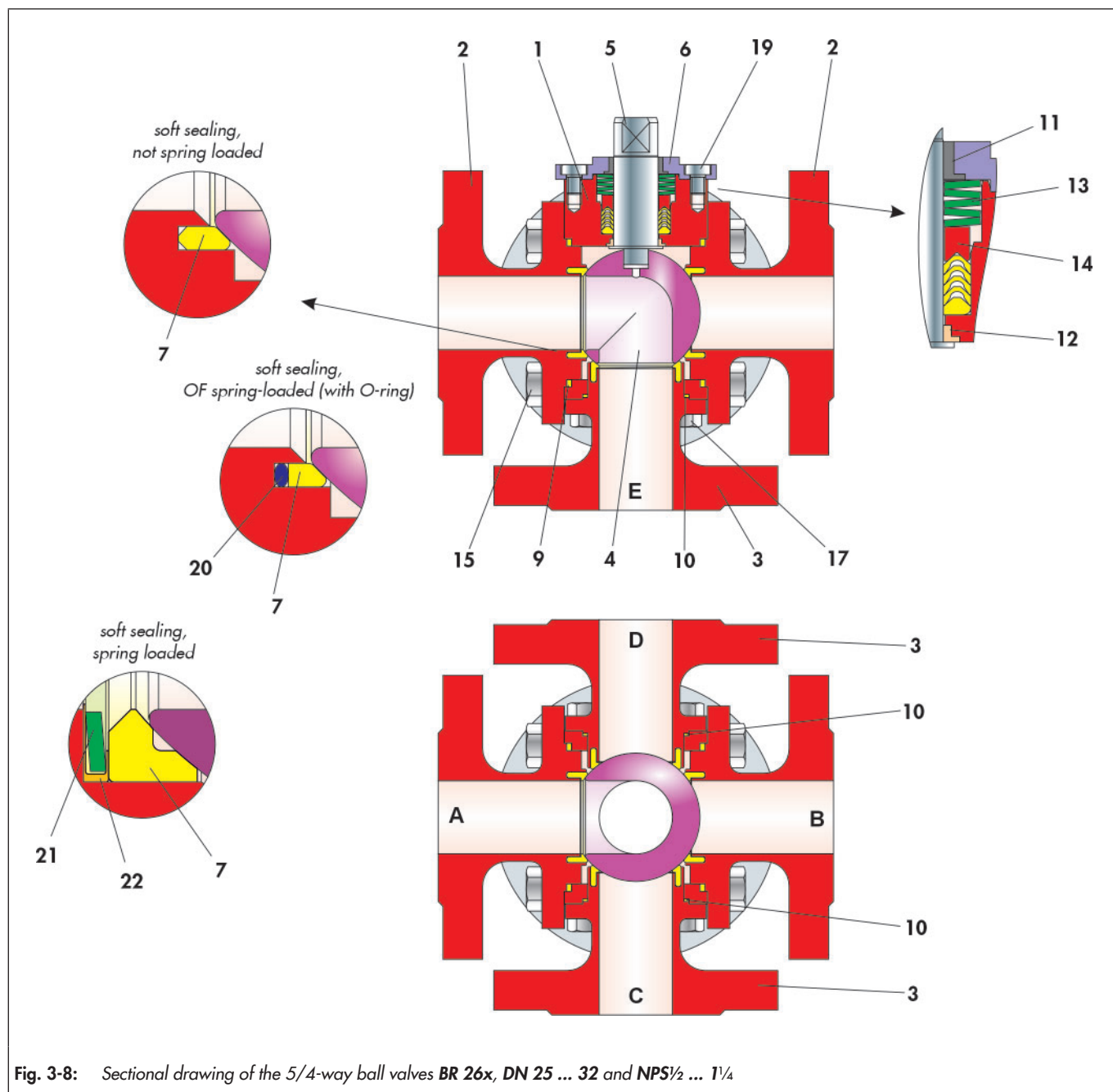

Fig. 3-8: Sectional drawing of the 5/4-way ball valves BR 26x, DN 25 ... 32 and NPS½ ... 1¼

Table 3-7: Parts list of the 5/4-way ball valves BR 26x, DN 25 ... 32 and NPS½ ... 1¼

Item	Description
1	Main body
2	Body flange
3	Outlet flange
4	Ball
5	Control shaft
6	Stuffing box flange
7	Seat ring

Item	Description
9	Sealing
10	Sealing
11	Bearing bush
12	Bearing bush
13	Disc spring set
14	V-ring packing
15 ¹⁾	Stud bolt / Screw

Item	Description
16 ¹⁾	Nut
17 ¹⁾	Stud bolt / Screw
18 ¹⁾	Nut
19	Screw
20	O-ring
21	Disc spring
22	Disc spring jacket

¹⁾ Depending on the nominal width, stud bolts can be fitted with nuts or screws.

3.5.7.3 Assembly of the main body

- ⇒ Place the main body (1) on an even and clean work surface, so that the inside of the ball valve is easy to reach.
- ⇒ Screw the lightly greased stud bolts (15) into the main body (1).

i Info

- Depending on the version, stud bolts (15) with nuts (16) or screws (15) can be used.
- If screws are used, the above step is not necessary.

- ⇒ Press the bearing bush (12) at the appropriate location into the main body (1).
- ⇒ Push the control shaft (5) through the mounted bearing bush (12) into the main body. Make sure the control shaft can be moved.
- ⇒ Slightly rotate the V-ring packing (14) so it can be pushed over the mounted control shaft (5) more easily and insert it at the appropriate packing location into the main body (1). For the arrangement of the V-rings, see Fig. 3-8
- ⇒ Place the disc springs (13) onto the packing. For the arrangement of the disc springs, see Fig. 3-8.
- ⇒ Press the bearing bush (11) into the packing box flange (6).
- ⇒ Place the packing box flange (6) over the control shaft (5) onto the main body (1).
- ⇒ Lightly grease the screws (19).
- ⇒ Adjust the stuffing box flange with the screws (19).

i Info

Only tighten the screws hand-tight; final assembly is carried out in a later assembly step.

3.5.7.4 Assembly of the ball valve

- ⇒ To proceed with assembly, turn the main body so that the side (E) of the outlet flange faces upwards and all five flange mounting sides are freely accessible.
- ⇒ Place the ball (4) in the main body and push it with the groove onto the cam of the mounted control shaft (5).
- ⇒ The outlet flanges (3) (page C, D and E) pre-assembled in chapter 3.5.7.2 are placed on the main body (1) and adjusted with the lightly greased screws (17).

i Info

- Depending on the version, stud bolts (17) with nuts (18) or screws (17) can be used.
- Only tighten the screws or nuts hand-tight; final assembly is carried out in a later assembly step.

The body flanges (2) pre-assembled in chapter 3.5.7.1 (side A and B) are placed on the main body (1) one after the other and adjusted with the nuts (16).

i Info

- Depending on the version, stud bolts (15) with nuts (16) or screws (15) can be used.
- Only tighten the screws or nuts hand-tight; final assembly is carried out in a later assembly step.

- ⇒ Properly align the body flanges (2), the outlet flanges (3) as well as the packing box flange (6).
- ⇒ Tighten all nuts and bolts evenly in a criss-cross pattern.

! NOTE

Damage due to improper assembly!

When tightening the screw connections, ensure that the ball moves smoothly.

i Info

- For permissible torque for tightening the body flanges and the stuffing box flange, see Table 15-1 and Table 15-3 in Chapter "15.1.1 Tightening torques".
- Prior to the leak test, the ball valve should be actuated a few times so that the ball can centre on the seat rings and provide an optimal seal.

3.5.8 Assembly of the 5/4-way ball valve BR 26x, DN 40 to 200 and NPS1½ to 8

3.5.8.1 Pre-assembly of the body flanges (A, B C and D)

- ⇒ Place the body flanges (2) with the flange side facing down on an even and clean work surface.

Seat ring soft seal version, not spring-loaded

- ⇒ Insert the seat ring (7) into the respective body chamber of the four body flanges (2).

Seat ring soft seal version, spring-loaded on all sides

- ⇒ Place the disc spring jacket (22) on the disc spring (21).

i Info

Pull on the disc spring jacket so that the long side of the jacket is positioned towards the body and the short side towards the seat ring. This ensures the sealing function.

Design and principle of operation

- ⇒ Insert the jacketed disc spring (21) into the body chambers in the four body flanges (2).
- ⇒ Press the seat ring (7) up to the disc spring.

Seat ring soft seal version, OF spring-loaded

- ⇒ Insert the O-ring (20) into the respective body chamber of the four body flanges (2).
- ⇒ Press the seat ring (7) up to the O-ring (20).

Further assembly for all versions

- ⇒ Insert the sealing (9) into the corresponding recesses in the four body flanges (2).

3.5.8.2 Pre-assembly of the body flange (E)

- ⇒ Place the body flange (2) with the flange side facing down on an even and clean work surface.
- ⇒ Insert the bearing ring (30) into the body chamber of the body flange (2).
- ⇒ Insert the sealing (9) into the corresponding recesses in the body flange (2).

3.5.8.3 Assembly of the main body

- ⇒ Place the main body (1) on an even and clean work surface, so that the inside of the ball valve is easy to reach.
- ⇒ Screw the lightly greased stud bolts (15) into the main body (1).

i Info

- Depending on the version, stud bolts (15) with nuts (16) or screws (15) can be used.
- If screws are used, the above step is not necessary.

3.5.8.4 Pre-assembly of the bonnet flange

- ⇒ Push the bearing bush (12) with a slight rotary movement onto the control shaft (5).
- ⇒ Insert the control shaft (5) from the inside through the control shaft duct into the bonnet flange (23).

! NOTE

Damage due to improper assembly!

- ⇒ Do not damage the sealing surface of the control shaft (5).
- ⇒ Make sure that the bearing bush (12) and the control shaft (5) do not tilt when positioning in the Bonnet flange (23).

- ⇒ Slide the V-ring packing (14) over the mounted control shaft (5) with a slight rotating movement and insert it into the packing location of the Bonnet flange (23). For the arrangement of the V-rings, see Fig. 3-9.

- ⇒ Place the disk spring set (13) over the control shaft (5) up to the V-ring packing (14). For the arrangement of the disk springs, see Fig. 3-9.
- ⇒ Place the bush (24) over the control shaft (5) up to the disk springs (13).
- ⇒ Press the ring (27) into the stuffing box flange (6).
- ⇒ Insert the O-ring (26) into the stuffing box flange (6).
- ⇒ Place the stuffing box flange (6) over the control shaft onto the bonnet flange (23).
- ⇒ Lightly grease the screws (19).
- ⇒ Adjust the stuffing box flange with the screws (19).

i Info

Only tighten the screws hand-tight; final assembly is carried out in a later assembly step.

3.5.8.5 Final assembly of the main body

The body flange (2) (page E) pre-assembled in chapter 3.5.8.2 is attached to the main body (1) and adjusted with the nuts (16).

i Info

- Depending on the version, stud bolts (15) with nuts (16) or screws (15) can be used.
- Only tighten the screws hand-tight; final assembly is carried out in a later assembly step.

- ⇒ Carefully insert the ball (4) into the main body. Insert the lower trunnion of the ball into the bearing ring (30) in the body flange.
- ⇒ Push the upper bearing bush (28) onto the trunnion of the ball (4) with a slight turning movement.
- ⇒ Insert the O-ring (25) into the main body (1).
- ⇒ Carefully place the pre-assembled bonnet flange (23) onto the main body (1).

! NOTE

- ⇒ Do not damage the O-ring (25).

- ⇒ Lightly grease the trunnion of the ball (4).
- ⇒ Rotate the bonnet flange until the control shaft engages with the ball and the bonnet flange slides in the main body.
- ⇒ Rotate the bonnet flange (23) until the bores of both components are aligned with each other.
- ⇒ After applying grease to the screws (29) both parts are screwed together, evenly and in alternating pattern.

i Info

For permissible torque for tightening the connection of the bonnet flange can be found in Table 15-4 in Chapter "15.1.1 Tightening torques".

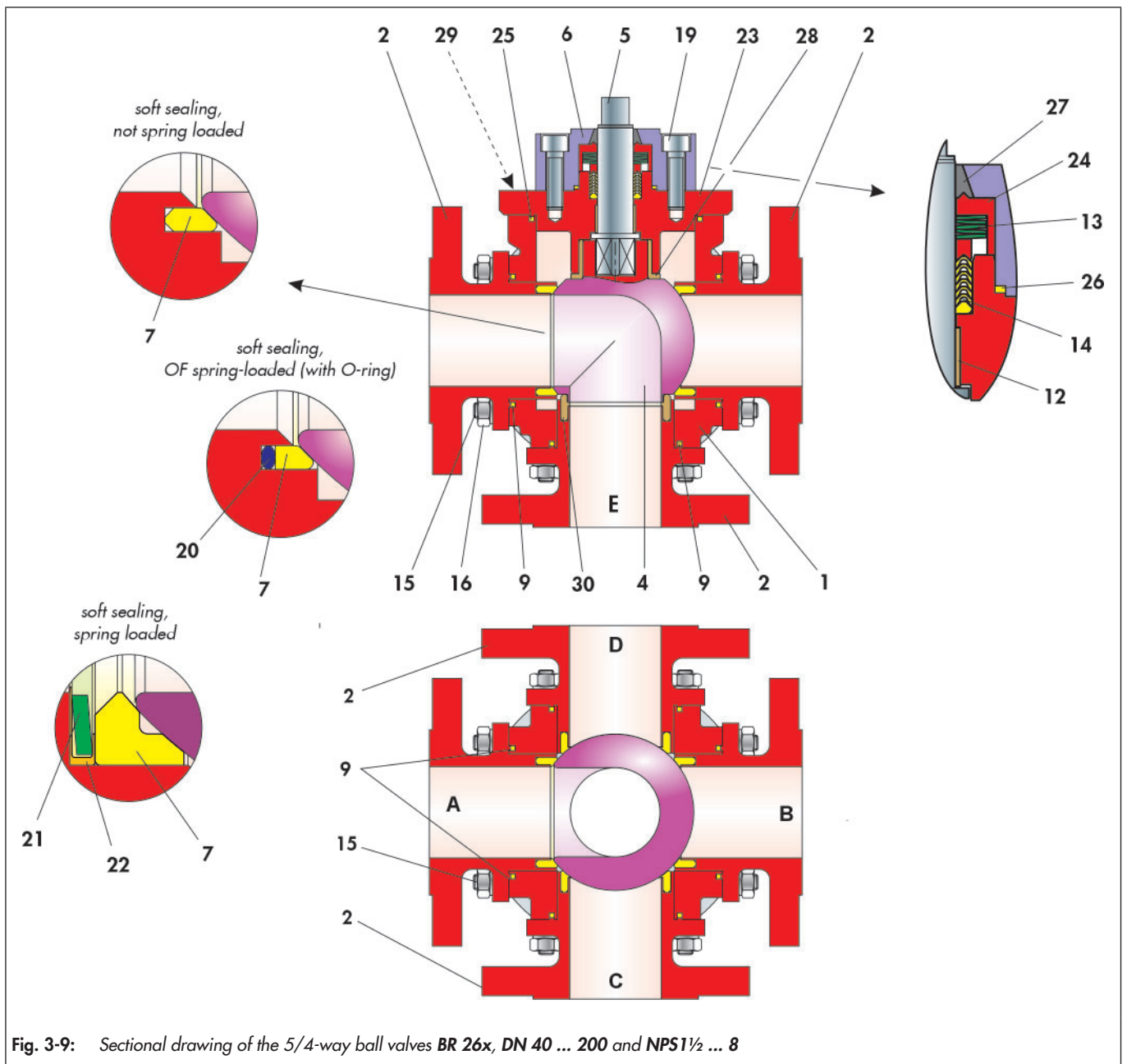

Table 3-8: Parts list of the 5/4-way ball valves BR 26x, DN 40 ... 200 and NPS1½ ... 8

Item	Description
1	Main body
2	Body flange
4	Ball
5	Control shaft
6	Stuffing box flange
7	Seat ring
9	Sealing
12	Bearing bush

Item	Description
13	Disc spring set
14	V-ring packing
15 ¹⁾	Stud bolt / Screw
16 ¹⁾	Nut
19	Screw
20	O-ring
21	Disc spring
22	Disc spring jacket

Item	Description
23	Bonnet flange
24	Bush
25	Ring
26	Ring
27	Ring
28	Bearing bush
29	Screw
30	Bearing ring

¹⁾ Depending on the nominal width, stud bolts can be fitted with nuts or screws.

3.5.8.6 Assembly of the ball valve

- ⇒ Turn the main body for further installation so that all four mounting sides (A, B, C and D) are easy to reach.
- ⇒ The body flanges (2) pre-assembled in chapter 3.5.8.1 (side A, B, C and D) are placed on the main body (1) one after the other and adjusted with the nuts (16).

i Info

- Depending on the version, stud bolts (15) with nuts (16) or screws (15) can be used.
 - Only tighten the screws or nuts hand-tight; final assembly is carried out in a later assembly step.
-

- ⇒ To complete the assembly, align the body flanges (2) and the stuffing box flange (6).
- ⇒ Tighten all screws or nuts evenly in alternating pattern.

i Info

- For permissible torque for tightening the body flanges and the stuffing box flange, see Table 15-1 and Table 15-3 in Chapter “15.1.1 Tightening torques”.
 - Prior to the leak test, the ball valve should be actuated a few times so that the ball can centre on the seat rings and provide an optimal seal.
-

4 Shipment and on-site transport

The work described in this chapter may only be performed by specialist personnel qualified to perform the corresponding task.

! NOTE

Damage to the ball valve due to improper transport and storage!

⇒ Ball valves must be handled, transported and stored with care.

4.1 Accepting delivery

Perform the following steps after receiving the goods:

- ⇒ Check the scope of supply. Compare the delivered goods with the delivery note.
- ⇒ Check the supply for transport damage. Report transport damage to PFEIFFER and the transport company (see the delivery note).

4.2 Unpacking the multi-way ball valve

Carry out the following steps:

- ⇒ Unpack the ball valve directly before lifting for installation into the pipe.
- ⇒ Leave the ball valve on the pallet or in the transport container for on-site transport.
- ⇒ The protective caps on the ball valve inlet and outlet prevent foreign matter from entering the ball valve and damaging it. Only remove the protective caps prior to installation in the pipe.
- ⇒ Dispose of the packaging properly.

4.3 Transporting and lifting the multi-way ball valve

! DANGER

Danger due to falling of suspended loads!

Do not stand under suspended loads.

! WARNING

Overturning of the lifting equipment and damage to the load lifting equipment by exceeding the lifting capacity!

- ⇒ Only used approved lifting equipment and load lifting equipment whose lifting capacity corresponds at least to the weight of the ball valve including the actuator.
- ⇒ Take the weights from the respective data sheet.

! WARNING

Danger of injury due to the tipping of the ball valve!

- ⇒ Observe the centre of gravity of the ball valve.
- ⇒ Secure the ball valve against tipping and twisting.

! NOTE

Damage to the ball valve due to improper fastening of the sling!

The screwed-in lifting eyes on actuators are used only for actuator assembling and disassembling as well as for lifting the actuator without the ball valve. These lifting eyes are not intended for lifting the complete ball valve.

- ⇒ When lifting the ball valve, make sure that the entire load is carried by the sling that is fastened to the ball valve body.
- ⇒ Do not fasten the load-bearing sling to the actuator, hand wheel or other components.
- ⇒ Do not use the control air lines, accessories or other components with safety functions for suspension or damage them.

4.3.1 Transporting

The ball valve can be transported using lifting equipment such as a crane or a forklift.

- ⇒ Leave the ball valve on the pallet or in the transport container for transport.
- ⇒ Ball valves that weigh more than approx. 10 kg should be transported on a pallet (or supported similarly) (also to the installation site). The packaging should protect the valve from damage.
- ⇒ Comply with the transport conditions.

Transport conditions

- ⇒ Protect the ball valve against external influences, such as impacts.
- ⇒ Do not damage the corrosion protection (paint, surface coating). Repair damage immediately.
- ⇒ Protect the ball valve against moisture and dirt.

4.3.2 Lifting

When installing the ball valve in the pipe, larger ball valves can be lifted using lifting equipment such as a crane or forklift.

Conditions for lifting

- ⇒ Use a hook with a safety clamp as the suspension element so that the sling cannot slip off the hook during lifting and transport, see Fig. 4-1.

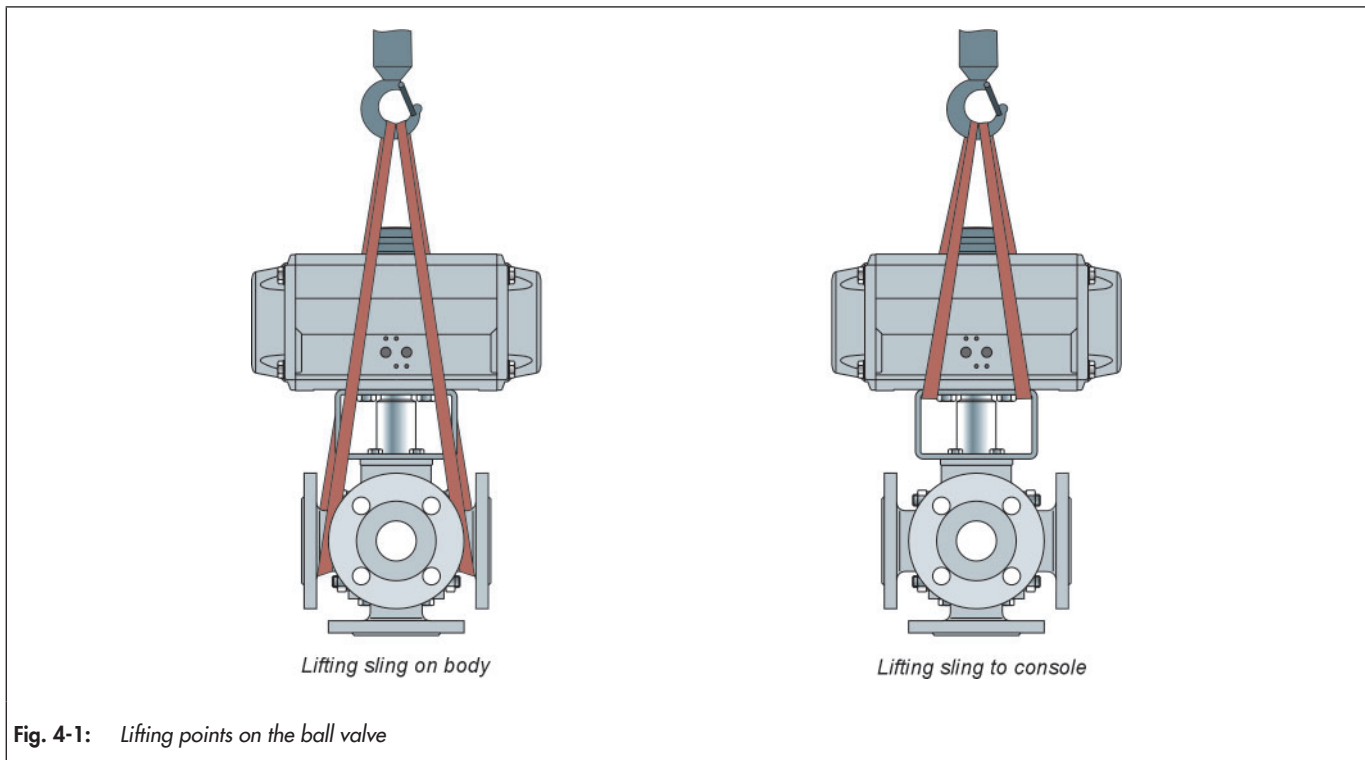

Fig. 4-1: Lifting points on the ball valve

- ⇒ Secure the sling against shifting and slipping off.
- ⇒ Fasten the sling such that it can be removed again after installation in the pipe.
- ⇒ Avoid swinging and tipping the ball valve.
- ⇒ In the case of interruptions in work, do not leave the lifting equipment suspended in the air for a long period of time.
- ⇒ Lift the ball valve aligned in the same direction in which it will be installed in the pipe.
- ⇒ Always lift the ball valve in the centre of gravity of the load to prevent uncontrolled tipping.
- ⇒ Make sure that any slings between the lifting eyes on the rotary actuator and suspension element are not loaded. These slings are used only to secure the load against turning over while lifting. Before lifting the ball valve, pretension this sling so it is taut.

⚠ WARNING

Danger due to incorrect lifting and transport!

The lifting points for the lifting slings shown in the schematic drawing serve as examples for most valve variants. On site the conditions for lifting and transporting the valve can change however.

- ⇒ The operator makes sure that the valve is lifted and transported safely.

4.3.3 Lifting points on the body

- ⇒ Fasten a lifting sling to each flange of the housing and on the suspension element (e.g. hook) of the crane or forklift, see Fig 4-1. When doing so, ensure the safety, bearing capacity and length of the lifting slings
- ⇒ In the case of an actuator with a lifting eye: fasten additional lifting slings to the lifting eye on the actuator and on the suspension element.
- ⇒ Lift the ball valve carefully. Check if the load lifting equipment holds.
- ⇒ Move the ball valve at a constant speed to the installation site.
- ⇒ Install the ball valve in the pipe, see chapter 5.4.
- ⇒ After installation in the pipe: check that the flanges are firmly tightened and that the ball valve holds in the pipe.
- ⇒ Remove the lifting slings.

4.3.4 Lifting points on the bracket

- ⇒ Fasten a lifting sling to the bracket and the suspension element (e.g. hook) of the crane or forklift, see Fig. 4-1. When doing so, ensure the safety, bearing capacity and length of the lifting slings.
- ⇒ In the case of an actuator with a lifting eye: fasten additional lifting slings to the lifting eye on the actuator and on the suspension element.
- ⇒ Lift the ball valve carefully. Check if the load lifting equipment holds.

- ⇒ Move the ball valve at a constant speed to the installation site.
- ⇒ Install the ball valve in the pipe, see chapter 5.4
- ⇒ After installation in the pipe: check that the flanges are firmly tightened and that the ball valve holds in the pipe.
- ⇒ Remove the lifting slings.

4.4 Storing the multi-way ball valve

! NOTE

Damage to the ball valve due to improper storage!

- ⇒ Comply with the storage conditions
 - ⇒ Avoid long storage periods
 - ⇒ In the case of deviating storage conditions and a longer storage period, contact PFEIFFER
-

i Info

PFEIFFER recommends checking the ball valve and the storage conditions regularly during a longer storage period.

- ⇒ In the case of storage prior to installation, the ball valve should normally be stored in a closed room where it is protected against harmful influences such as impacts, dirt or moisture. A room temperature of $25\text{ °C} \pm 15\text{ °C}$ is recommended.
- ⇒ In particular, the actuator and the ends of the ball valve to the pipe connection may not be damaged by mechanical or any other influences.
- ⇒ Do not stack the ball valves.
- ⇒ Prevent condensation in damp rooms. Use a desiccant or heater.
- ⇒ The ball valve must be stored in its protective packaging and/or with the protective caps on the connection ends.
- ⇒ Ball valves that weigh more than approx. 10 kg should be stored on a pallet (or supported similarly).
- ⇒ Ball valves are usually delivered in a completely open position. They must be stored in the position in which they were delivered. The actuating device must not be actuated.
- ⇒ Do not place any objects on the ball valve.

5 Installation

The work described in this chapter may only be performed by specialist personnel qualified to perform the corresponding task. The following instructions apply additionally for ball valves. Observe chapter "4.3 Transporting and lifting the multi-way ball valve" for transport to the installation site.

5.1 Installation conditions

Operator level

The operator level for the ball valve is the front view on all operating elements of the ball valve including the attachments from the perspective of operating personnel.

The plant operator must make sure that operating personnel can carry out all work after the device is installed safely and can access it easily from the operator level.

Pipe routing

The guidelines applicable on site apply for the installation of ball valves in the pipe.

Install the ball valve such that there is low vibration and no mechanical stress. Observe the sections "Installation orientation" and "Support and mounting" in this chapter.

Install the ball valve so there is enough space to replace the actuator and ball valve as well as to perform maintenance work.

Installation position

The ball valve can be installed in any installation position. PFEIFFER recommends however to install the ball valve in general so that the actuator points up in a vertical position.

In the following versions, the ball valve with actuator must be installed facing upwards or a corresponding support must be provided:

- Nominal sizes from DN 100 / NPS4
- Ball valves with a stem extension or insulating part.
- ⇒ In the case of deviations from this installation position, contact PFEIFFER.

Support and mounting

The plant manufacturer is responsible for the selection and implementation of a suitable support or mounting for the installed ball valve as well as the pipe.

Venting

Vents are screwed into the exhaust air connections of pneumatic and electropneumatic devices to ensure that the generated exhaust air can be released to the outside (protection against overpressure in the device). Furthermore, vents allow the intake of air (protection against underpressure in the device).

- ⇒ Carry out venting on the side that faces away from the operator level.

- ⇒ When connecting the attachments, make sure that they can be accessed from the operator level safely and easily.

5.2 Preparing for assembly

Ball valves must be handled, transported and stored with care, see Chapter "4 Delivery and on-site transport".

Perform the following steps after receiving the goods:

- ⇒ Check the scope of supply. Compare the delivered goods with the delivery note.
- ⇒ Check the supply for transport damage. Report transport damage to PFEIFFER and the transport company (see the delivery note).

Ensure the following conditions prior to assembly:

- The ball valve is clean.
- The ball valve data on the type plate (type, nominal size, material, nominal pressure and temperature range) matches the plant conditions (nominal size and nominal pressure of the pipe, medium temperature, etc.). For details about the marking, see Chapter "2 Markings on the device".
- Desired or required additional fittings, see Chapter "3.2 Additional fittings", are installed or prepared as far as necessary before the assembly of the ball valve.

5.3 Assembling the multi-way ball valve and actuator

PFEIFFER ball valves are supplied in working order. In individual cases, the actuator and ball valve are delivered separately and must be assembled. The tasks are listed below that are necessary for assembly and prior to the commissioning of the ball valve.

WARNING

Danger and damage due to retrofitting an actuator unit!

The subsequent fitting of an actuator unit can pose a danger to the user and cause damage to the pipe system.

- ⇒ *Torque, direction of rotation, actuating angle and the setting of the stops must be adjusted in all positions of the ball valve.*

Danger and damage due to use of an electrical actuator!

- ⇒ *It must be ensured that the actuator in the end positions is turned off by the limit switch signal.*
- ⇒ *If shut-off takes place in an intermediate position due to the signal of the torque switch, this signal should be used in addition for an error message. The fault must be remedied as soon as possible see Chapter "8 Malfunction".*
- ⇒ *For further instructions, see the electrical actuator manual.*

⚠ WARNING

Danger and damage due to high external loads on an actuator unit!

Actuators are not "stepladders".

- ⇒ Loads may not be applied to the actuators as they can damage or destroy the ball valve.

Danger and damage due to heavy actuator units!

Actuators that are heavier than the weight of the ball valve can pose a danger to the user and cause damage to the pipe system.

- ⇒ These actuators must be supported if they generate a bending stress on the ball valve due to their size and/or installation situation.

! NOTE

Damage to the ball valve due to the incorrect setting of the end stops!

The actuating device is adjusted to the operating data specified in the order.

- ⇒ The adjustment of the actuator is adapted to the switching positions of the multi-port ball valve and must not be changed without the consent of PFEIFFER.

5.4 Installing the multi-way ball valve in the pipe

5.4.1 General

- ⇒ Transport the ball valve in its original packaging to the installation site and unpack it only there.
- ⇒ Inspect the ball valve and actuator for transport damage. Damaged ball valves or actuators may not be installed.
- ⇒ A functional test is to be carried out at the beginning of installation for manually-operated ball valves: the ball valve must close and open correctly. Detected malfunctions must be fixed before commissioning. See also chapter 8.
- ⇒ Make sure that only ball valves are installed whose pressure classes, connection type (flow rate), type of lining and connection dimensions match the conditions of use. See the corresponding marking on the ball valve.

⚠ DANGER

Danger due to exceeding the limits of use!

Exceeding the limits of use can pose a danger to the user and cause damage to the pipe system.

- ⇒ No ball valve may be installed whose permissible pressure/temperature range is not sufficient for the operating conditions.
- ⇒ The max. permissible limits of use are marked on the ball valve, see Chapter "2 Markings on the device".
- ⇒ The permissible range is defined in Chapter "1 Safety instructions and safety measures".

- ⇒ Handle the ball valve with care and observe the instructions for the flange connection.
- ⇒ The counterflanges must have smooth sealing surfaces. Other shapes must be agreed upon with PFEIFFER.
- ⇒ The connection ends of the pipe must align with the ball valve connections and have plane-parallel ends.
- ⇒ Prior to installation, the ball valve and the connected pipe must be carefully cleaned of any contamination, in particular solid foreign matter.
- ⇒ The sealing surfaces on the flange connection and the utilized flange seals must in particular be free of all contamination during installation.
- ⇒ Optionally, an arrow is marked on the body. The direction of the arrow must correspond to the direction of flow in the pipe.
- ⇒ When pushing the ball valve and the required flange seals into an already assembled pipe, the distance between the pipe ends must be measured such that all contact surfaces of the ball valve and seals remain undamaged.

! NOTE

Damage to the sealing surfaces and seals or untight flange connection due to improper assembly!

- ⇒ After longer storage of the ball valve, retighten the body screws after installation with the corresponding tightening torques according to Table 15-1 or Table 15-2 in Chapter "15.1.1 Adjustable stuffing box".

- ⇒ The connection data for the actuator unit must match the data for the control unit. See type plate(s) on the actuator unit. The relevant instructions apply for connecting the actuator to the control unit.
- ⇒ Vents are screwed into the exhaust air connections of pneumatic and electropneumatic devices to ensure that the generated exhaust air can be released to the outside (protection against overpressure in the device).
Furthermore, vents allow the intake of air (protection against underpressure in the device).
- ⇒ Carry out venting on the side that faces away from the working area of operating personnel.
- ⇒ When installing peripheral devices, make sure that they can be operated from the working area of operating personnel.

5.4.2 Switching position and fail-safe position

By using different ball port configurations, horizontal and vertical flow paths are achievable by the various flow patterns.

Special flow patterns are also possible.

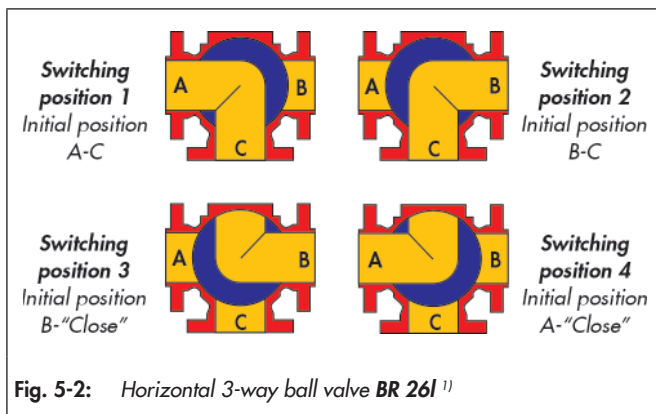

Fig. 5-2: Horizontal 3-way ball valve BR 26l ¹⁾

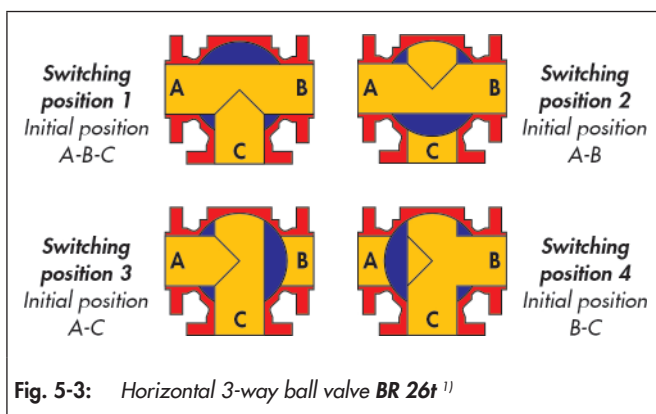

Fig. 5-3: Horizontal 3-way ball valve BR 26t ¹⁾

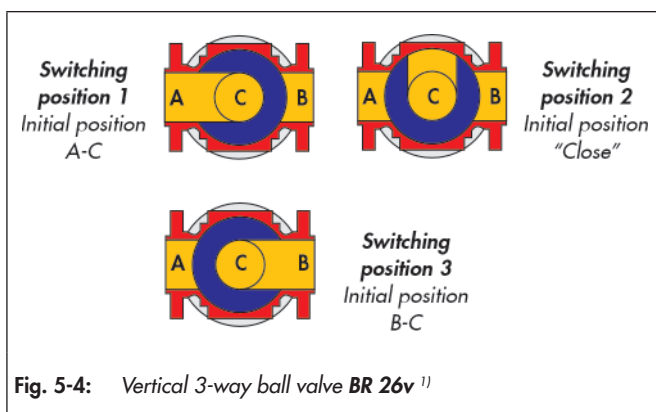

Fig. 5-4: Vertical 3-way ball valve BR 26v ¹⁾

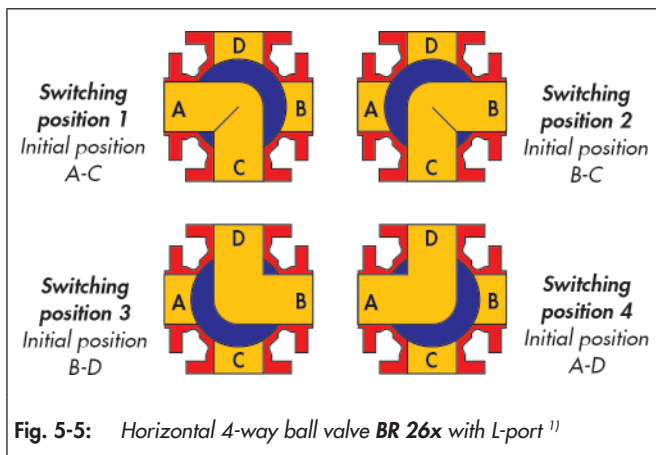

Fig. 5-5: Horizontal 4-way ball valve BR 26x with L-port ¹⁾

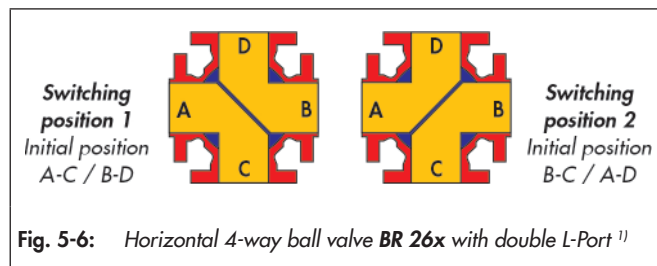

Fig. 5-6: Horizontal 4-way ball valve BR 26x with double L-Port ¹⁾

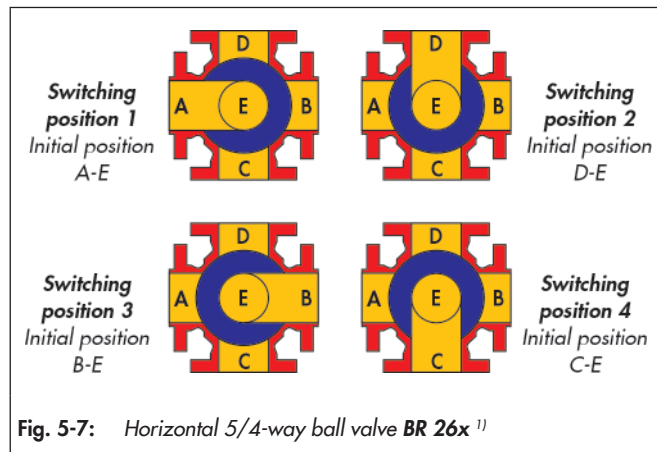

Fig. 5-7: Horizontal 5/4-way ball valve BR 26x ¹⁾

¹⁾ Top view = actuator at the top

i Info

Multi-way ball valves are delivered with the appropriate ball depending on the function of the ball valve.

The schematics for the ball valve:

- BR 26l, see Fig. 5-1
- BR 26t, see Fig. 5-2
- BR 26v, see Fig. 5-3
- BR 26x, see Fig. 5-4 to Fig. 5-6

The supplied multi-way ball valve must be suitable for the pipe section.

The multi-way ball valve ports designated A, B, C, D and/or E must be connected as shown in Fig. 5-1 to Fig. 5-6 in accordance with the intended switching positions in the pipeline.

⇒ Check the function before installing the ball valve.

5.4.3 Installing the multi-port ball valve

- ⇒ Close the ball valve in the pipe for the duration of the installation.
- ⇒ Remove the protective caps on the ball valve openings prior to installation.
- ⇒ Lift the ball valve with suitable lifting equipment at the installation site, see chapter “4.3 Transporting and lifting the multi-way ball valve”.
- ⇒ Use correct flange seals.
- ⇒ Clean the sealing surfaces on the ball valve and pipe if necessary.

- ⇒ Screw the pipe together with the ball valve without tension.

NOTE

Damage to the sealing surfaces and seals or untight flange connection due to improper assembly!

- ⇒ Tighten the flange connections evenly and in a criss-cross pattern with the torques indicated in Table 15-5 in Chapter "15.1.1 Tightening torques".

- ⇒ After installing the ball valve, open it slowly in the pipe.

NOTE

Damage to the ball valve due to a sudden pressure increase and resulting high flow speed!

Open the ball valve slowly in the pipe during commissioning.

- ⇒ Check the correct function of the ball valve.

5.5 Checking the assembled ball valve

5.5.1 Functional test

WARNING

Danger of injury due to pressurised components and escaping medium!

- ⇒ Do not loosen the screw of an optional test connection while the ball valve is pressurised.

Danger of crushing due to moving actuator- and control shaft!

- ⇒ Do not reach into the yoke as long as the pneumatic power is connected to the actuator.
- ⇒ Before working on the ball valve, interrupt and lock pneumatic energy and the control signal.
- ⇒ Vent the actuator.
- ⇒ Do not allow the jamming of objects in the yoke to hinder the operation of the actuator- and control shaft.
- ⇒ If the actuator- and control shaft are blocked (e.g. due to "seizure" if not actuated for a long period of time"), release the residual energy of the actuator (spring tension) before releasing the blockage, see the corresponding actuator documentation.

Danger of injury due to escaping exhaust air!

During operation, when regulating or when opening and closing the ball valve, exhaust air can escape, for example from the actuator.

- ⇒ Wear eye protection and, if necessary, hearing protection when working near valves.

- ⇒ At the end of installation, perform a functional test with the control signals:

The ball valve must close and open correctly according to the control commands. Detected malfunctions must be fixed before commissioning, see Chapter "8 Malfunction".

WARNING

Danger due to improperly executed control commands!

Incorrectly executed control commands can cause serious injuries or even death and damage to the pipe system.

- ⇒ Check the actuator unit and control command., see chapter "8 Malfunction".

5.5.2 Pressure test of the pipe section

The pressure test was already performed on the ball valves by PFEIFFER. Observe the following for the pressure test of a pipe section with installed ball valves:

- ⇒ First carefully rinse newly installed pipe systems in order to wash out all foreign matter.
- ⇒ Ensure the following conditions for the pressure test:
 - Ball valve open: the test pressure may not exceed the value $1.5 \times PN$ (according to the type plate).
 - Ball valve closed: the test pressure may not exceed the value $1.1 \times PN$ (according to the type plate).

If a ball valve leaks, observe chapter "8 Malfunction".

i Info

The plant operator is responsible for performing the pressure test. After Sales Service at PFEIFFER can provide you with support for the planning and implementation of a pressure test specific to your plant.

5.5.3 Rotary movement

The rotary movement of the actuator- and control shaft must be linear without any jerky movements.

- ⇒ Open and close the ball valve. When doing so, observe the movement of the actuator shaft.
- ⇒ Set the maximum and minimum control signal in succession to check the end positions of the ball valve.
- ⇒ Check the display on the position indicator.

5.5.4 Fail-safe position

- ⇒ Close the signal pressure line.
- ⇒ Check whether the ball valve is in the intended end position".

6 Start-up

The work described in this chapter may only be performed by specialist personnel qualified to perform the corresponding task.

WARNING

Danger of burning due to hot or cold components and pipe!

Ball valve components and pipes can become very hot or very cold during operation and cause burns upon contact.

⇒ Let the components and pipes cool down or warm up.

⇒ Wear protective garments and protective gloves.

Danger of injury due to pressurised components and escaping medium!

⇒ Do not loosen the screw of the optional test connection while the ball valve is pressurised.

Danger of crushing due to moving actuator- and control shaft!

⇒ Do not reach into the yoke as long as the pneumatic power is connected to the actuator.

⇒ Before working on the ball valve, interrupt and lock pneumatic energy and the control signal.

⇒ Vent the actuator.

⇒ Do not allow the jamming of objects in the yoke to hinder the operation of the actuator- and control shaft.

⇒ If the actuator- and control shaft are blocked (e.g. due to "seizure" if not actuated for a long period of time"), release the residual energy of the actuator (spring tension) before releasing the blockage, see the corresponding actuator documentation.

Danger of injury due to escaping exhaust air!

During operation, when regulating or when opening and closing the ball valve, exhaust air can escape, for example from the actuator.

⇒ Wear eye protection and, if necessary, hearing protection when working near valves.

Commissioning/recommissioning

- Open the ball valves slowly in the pipe. Opening slowly prevents a sudden increase in pressure and a resulting high flow speed that damages the ball valve.
- Check the correct function of the ball valve.

Ensure the following conditions prior to commissioning/recommissioning:

- The ball valve is installed properly in the pipe, see Chapter "5 Assembly".
- The leak and function tests have been completed successfully, see Chapter "5.1 Installation conditions".
- The current conditions in the concerned plant section correspond to the design of the ball valve, see Intended use in Chapter "1 Safety instructions and safety measures".

7 Operation

As soon as the commissioning/recommissioning work is complete, see Chapter "6 Commissioning", the ball valve is ready for operation.

⚠ WARNING

Danger of burning due to hot or cold components and pipe!

Ball valve components and pipes can become very hot or very cold during operation and cause burns upon contact.

- ⇒ Let the components and pipes cool down or warm up.
- ⇒ Wear protective garments and protective gloves.

Danger of injury due to pressurised components and escaping medium!

- ⇒ Do not loosen the screw of the optional test connection while the ball valve is pressurised.

Danger of crushing due to moving actuator- and control shafts!

- ⇒ Do not reach into the yoke as long as the pneumatic power is connected to the actuator.
- ⇒ Before working on the ball valve, interrupt and lock pneumatic energy and the control signal.
- ⇒ Vent the actuator.
- ⇒ Do not allow the jamming of objects in the yoke to hinder the operation of the actuator- and control shaft.
- ⇒ If the actuator- and control shaft are blocked (e.g. due to "seizure" if not actuated for a long period of time"), release the residual energy of the actuator (spring tension) before releasing the blockage, see the corresponding actuator documentation.

Danger of injury due to escaping exhaust air!

During operation, when regulating or when opening and closing the ball valve, exhaust air can escape, for example from the actuator.

- ⇒ Wear eye protection and, if necessary, hearing protection when working near valves.

Observe the following points during operation:

- If required, after commissioning and reaching the operating temperature, tighten all flange connections between the pipe and ball valve with the corresponding tightening torques, see Table 15-5 in Chapter "15.1.1 Tightening torque".
- It can also be necessary to retighten the screw connections on the body sections with the corresponding tightening torques according to Table 15-1 to Table 15-4 in Chapter "15.1.1 Tightening torque".
- The ball valve/actuator unit must be actuated with the control signals.
- Ball valves that were delivered from the factory with an actuator are precisely adjusted. The user is responsible for any changes they make.

- For the manual operation or manual override of the actuator (if present), normal manual forces are sufficient and the use of extensions to increase the actuation torque is not permitted.
- In the case of ball valves with a hand lever, the position of the hand lever indicates the location of the bore in the ball. The hand lever moves in general parallel to the bore. Special versions are to be taken from the respective order.

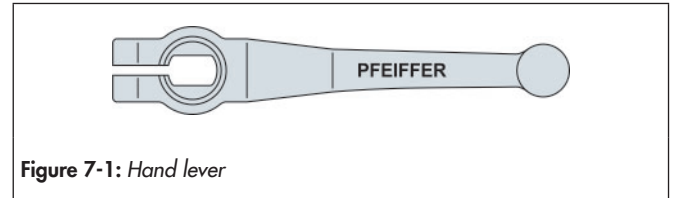

Figure 7-1: Hand lever

⚠ DANGER

Danger of injury due to jerky operation of the ball valve!

The failure to observe these warnings can cause extreme danger for persons or for the pipe system.

- ⇒ Do not open and close the ball valve suddenly to prevent pressure surges and/or a temperature shock in the pipe system.

- The ball valves can optionally have a test connection (e.g. 1/4") between the ball seal and the outer control shaft sealing. This makes it possible to check if the seal rings are not damaged.
- If a ball valve leaks, observe chapter "8 Malfunction".

8 Malfunction

When rectifying the malfunction, chapter "1 Safety instructions and safety measures" must be observed.

8.1 Detecting and rectifying errors

Type of fault	Possible cause	Measures
Leaks in the pipe connection	The flange connection of the ball valve is leaky	<p>Tighten the flange screws.</p> <hr/> <p>! NOTE</p> <p>An excessive tightening torque when retightening the flange screws can damage the ball valve and pipe!</p> <p><i>The permissible torque for retightening the pipe flange screws is limited.</i></p> <hr/> <p>Retighten the flange connection with the respective tightening torque, see Table 15-5 in Chapter "15.1.1 Tightening torques".</p> <p>If necessary, increase the tightening torque to max. 20%.</p>
	The flange connection is still leaky after retightening	<p>Loosen the flange connection and remove the ball valve, see chapter "1 Safety instructions and safety measures".</p> <p>Check the plane parallelism of the flange connection and correct if it is not sufficient.</p> <p>Check the flange seals, if the seals are damaged, replace them.</p>
Leaks in the body sections	Body section connection loosened	Retighten the connection of the body sections with the respective tightening torque, see Table 15-1 to Table 15-4 in Chapter "15.1.1 Tightening torques".
	Body sections untight after retightening	Replace the body sealing and/or ball valve, see chapter "1 Safety instructions and safety measures".
Increased medium flow rate with the ball valve closed	Leakage in the closed position	Remove and inspect the ball valve, see chapter "1 Safety instructions and safety measures".
	The ball valve is damaged	<p>Repairs are necessary</p> <p>Remove the ball valve, see chapter "1 Safety instructions and safety measures".</p> <p>Request spare parts from PFEIFFER, see Chapter "15.2 Spare parts".</p> <p>For the required repair instructions, see Chapter "12 Repairs"</p>
Leaks in the control shaft sealing	Medium escapes from the stuffing box	<p>Remove the ball valve, see chapter "1 Safety instructions and safety measures".</p> <p>Disassemble the ball valve and replace the control shaft sealing.</p> <p>Request spare parts from PFEIFFER, see Chapter "15.2 Spare parts".</p> <p>For the required repair instructions, see Chapter "12 Repairs"</p>
Malfunction	The actuator unit or control does not react	Check the actuator unit and control command.
	The actuator and control are OK	Remove and inspect the ball valve, see chapter "1 Safety instructions and safety measures".
	The ball valve is damaged	<p>Repairs are necessary.</p> <p>Remove the ball valve, see chapter "1 Safety instructions and safety measures".</p> <p>Request spare parts from PFEIFFER, see Chapter "15.2 Spare parts".</p> <p>For the required repair instructions, see Chapter "12 Repairs"</p>

Malfunction

Type of fault	Possible cause	Measures
Problems in the actuator unit	The pneumatic actuator must be removed	Disconnect the connection to the control pressure. Remove the actuator from the ball valve (observe the "Safety instructions and safety measures", see the included actuator unit manuals).

i Info

- In the case of malfunctions that are not listed in the table, contact the After Sales Service at PFEIFFER.
- Spare parts must be ordered indicating all the data according to the ball valve marking. Only original parts from PFEIFFER Chemie-Armaturenbau GmbH may be installed.
- If it is determined after removal that the ball valve material lining is not sufficiently resistant for the medium, parts must be selected made of a suitable material.

8.2 Carrying out emergency measures

In the case of a power supply failure, the ball valve automatically switches to the preset fail-safe position, see "Fail-safe positions" in Chapter "3 Design and principle of operation".

The system operator is responsible for emergency measures.

In case of a ball valve fault:

- Close the shut-off valves upstream and downstream of the ball valve so that no medium flows through the ball valve.
- Troubleshoot the error, see chapter "8.1 Detecting and rectifying errors".
- Rectify the fault that can be fixed as indicated in the instructions provided in this installation and operating manual. For malfunctions that cannot be fixed, contact the After Sales Service at PFEIFFER.

Recommissioning after malfunctions

See Chapter "6 Commissioning".

9 Servicing

The work described in this chapter may only be performed by specialist personnel qualified to perform the corresponding task.

The following documents are required in addition for the maintenance of the ball valve:

- Installation and operating manual for the installed actuator, e.g ▶ EB 31a for BR 31a rotary actuators or the corresponding actuator documentation of other manufacturers.

! WARNING

Danger of burning due to hot or cold components and pipe!

Ball valve components and pipes can become very hot or very cold during operation and cause burns upon contact.

- ⇒ Let the components and pipes cool down or warm up.
- ⇒ Wear protective garments and protective gloves.

Danger of injury due to pressurised components and escaping medium!

- ⇒ Do not loosen the screw of the optional test connection while the ball valve is pressurised.

Danger of crushing due to moving actuator- and control shaft!

- ⇒ Do not reach into the yoke as long as the pneumatic power is connected to the actuator.
- ⇒ Before working on the ball valve, interrupt and lock pneumatic energy and the control signal.
- ⇒ Vent the actuator.
- ⇒ Do not allow the jamming of objects in the yoke to hinder the operation of the actuator- and control shaft.
- ⇒ If the actuator- and control shaft are blocked (e.g. due to "seizure" if not actuated for a long period of time"), release the residual energy of the actuator (spring tension) before releasing the blockage, see the corresponding actuator documentation.

Danger of injury due to escaping exhaust air!

During operation, when regulating or when opening and closing the ball valve, exhaust air can escape, for example from the actuator.

- ⇒ Wear eye protection and, if necessary, hearing protection when working near valves.

Danger of injury due to preloaded springs!

Actuators with preloaded actuator springs are pressurised.

- ⇒ Release the compression from the preloaded springs before working on the actuator, see the corresponding actuator documentation.

Danger of injury due to residual medium in the ball valve!

When working on the ball valve, residual medium can escape and, depending on the medium properties, cause injuries (e.g. scalding, chemical burns).

- ⇒ Wear protective garments, protective gloves and eye protection.
- ⇒ Do not loosen the screw of the optional test connection while the ball valve is pressurised.
- ⇒ Bring the ball valve into the open position so the pressure is released from the ball.

! NOTE

Damage to the ball valve due to excessively high or low tightening torques!

The ball valve components must be tightened with specific torques. Excessively tightened components are subject to increased wear. Insufficiently tightened components can cause leakage.

- ⇒ Observe the tightening torques, see Table 15-1 to Table 15-4 in Chapter "15.1.1 Tightening torques".

Damage to the ball valve due to unsuitable tools!

- ⇒ Only use tools approved by PFEIFFER, see Chapter "15.1.3 Tools".

Damage to the ball valve due to unsuitable lubricants!

- ⇒ Only use lubricants approved by PFEIFFER, see Chapter "15.1.2 Lubricants".

i Info

The ball valve was checked by PFEIFFER prior to delivery.

- Certain test results certified by PFEIFFER are no longer valid when disassembling the ball valve. This includes the test for seat leakage and the leak test (outer tightness).
- If maintenance and repair work is performed without approval from the After Sales Service of PFEIFFER, the product guarantee will be voided.
- Only use original parts from PFEIFFER as spare parts that correspond to the original specification.
- Wear parts are not covered by the warranty.

9.1 Periodic tests

- ⇒ Depending on the conditions of use, the ball valve must be checked at defined intervals in order to take remedial measures prior to possible malfunctions. The plant operator is responsible for preparing a suitable test plan.

- ⇒ PFEIFFER recommends the following inspections that can be carried out during operation:

Test	Measures in the case of a negative test result
If present, check the optional test connection for tightness. WARNING! Danger of injury due to pressurised components and escaping medium! Do not loosen the screw of the test connection while the ball valve is pressurised.	Decommission the ball valve, see chapter "10 Decommissioning" Contact the After Sales Service at PFEIFFER for repairs, See chapter "12 Repairs".
Check the control shaft sealing for tightness from the outside.	The control shaft sealing with a PTFE V-ring packing is preloaded with a disc spring set and is therefore maintenance free.

Test	Measures in the case of a negative test result
Check the rotary movement of the actuator- and control shaft for smooth movement.	If the actuator- and control shaft are blocked, remove the blockage. WARNING! If the actuator- and control shaft are blocked (e.g. due to "seizure" if not actuated for a long period of time) they can release unexpectedly and move uncontrolled. This can lead to crushing if reaching into them. Before trying to release a blockage of the actuator- and control shaft, interrupt and lock the pneumatic energy and the control signal. Release the residual energy of the actuator (spring tension or compressed air reservoir) before releasing the blockage, see the corresponding actuator documentation.
If possible, check the fail-safe position of the ball valve by briefly interrupting the power supply.	Decommission the ball valve, see chapter "Decommissioning". Then determine the cause and remedy it, see Chapter "8 Malfunctions".
Check pipe connections and seals of the ball valve and actuator for leaks.	Regular maintenance work on the ball valve is not necessary, but when checking the pipe section, no medium may escape from the flange and screw connections of the body or from the control shaft sealing.

9.2 Maintenance work

- ⇒ The ball valve must be prepared before all maintenance work, see Chapter 12 "Repairs".
- ⇒ After all maintenance work, the ball valve must be checked prior to recommissioning, see Chapter "5.5 Checking the mounted multi-way ball valve".

9.2.1 Replacing the seat rings and ball

- ⇒ Check the condition of the ball and seat rings.
- ⇒ Remove the seat rings (4) as described in Chapter "12.2 Replacing the seat rings and ball". Check the seat rings as well as all plastic parts for damage and if in doubt replace them.
- ⇒ Also remove the ball (3). Check the ball as well as all plastic parts for damage and if in doubt replace them.

9.3 Ordering spare parts and consumables

Information about spare parts, lubricants and tools can be received from the After Sales Service at PFEIFFER.

Spare parts

Information on spare parts can be found in Chapter "15.2 Spare parts".

10 Decommissioning

The work described in this chapter may only be performed by specialist personnel qualified to perform the corresponding task.

WARNING

Danger of burning due to hot or cold components and pipe!

Ball valve components and pipes can become very hot or very cold during operation and cause burns upon contact.

- ⇒ Let the components and pipes cool down or warm up.
- ⇒ Wear protective garments and protective gloves.

Danger of injury due to pressurised components and escaping medium!

- ⇒ Do not loosen the screw of the optional test connection while the ball valve is pressurised.

Danger of crushing due to moving actuator- and control shaft!

- ⇒ Do not reach into the yoke as long as the pneumatic power is connected to the actuator.
- ⇒ Before working on the ball valve, interrupt and lock pneumatic energy and the control signal.
- ⇒ Vent the actuator.
- ⇒ Do not allow the jamming of objects in the yoke to hinder the operation of the actuator- and control shaft.
- ⇒ If the actuator- and control shaft are blocked (e.g. due to "seizure" if not actuated for a long period of time"), release the residual energy of the actuator (spring tension) before releasing the blockage, see the corresponding actuator documentation.

Danger of injury due to escaping exhaust air!

During operation, when regulating or when opening and closing the ball valve, exhaust air can escape, for example from the actuator.

- ⇒ Wear eye protection and, if necessary, hearing protection when working near valves.

Danger of injury due to residual medium in the ball valve!

When working on the ball valve, residual medium can escape and, depending on the medium properties, cause injuries (e.g. scalding, chemical burns).

- ⇒ Wear protective garments, protective gloves and eye protection.
- ⇒ Do not loosen the screw of the optional test connection while the ball valve is pressurised.
- ⇒ Bring the ball valve into the open position so the pressure is released from the ball.

To decommission the ball valve for maintenance and repair work or for disassembly, perform the following steps:

- ⇒ Close the valves upstream and downstream of the ball valve so that no medium flows through the ball valve.
- ⇒ Empty the pipe and ball valve completely.
- ⇒ Shut off the pneumatic power and lock it, to depressurise the actuator.
- ⇒ Let the pipe and ball valve components cool down or warm up.

11 Removal

The work described in this chapter may only be performed by specialist personnel qualified to perform the corresponding task.

WARNING

Danger of burning due to hot or cold components and pipe!

Ball valve components and pipes can become very hot or very cold during operation and cause burns upon contact.

- ⇒ Let the components and pipes cool down or warm up.
- ⇒ Wear protective garments and protective gloves.

Danger of crushing due to moving actuator- and control shaft!

- ⇒ Do not reach into the yoke as long as the pneumatic power is connected to the actuator.
- ⇒ Before working on the ball valve, interrupt and lock pneumatic energy and the control signal.
- ⇒ Vent the actuator.
- ⇒ Do not allow the jamming of objects in the yoke to hinder the operation of the actuator- and control shaft.
- ⇒ If the actuator- and control shaft are blocked (e.g. due to "seizure" if not actuated for a long period of time"), release the residual energy of the actuator (spring tension) before releasing the blockage, see the corresponding actuator documentation.

Danger of injury due to residual medium in the ball valve!

When working on the ball valve, residual medium can escape and, depending on the medium properties, cause injuries (e.g. scalding, chemical burns).

- ⇒ Wear protective garments, protective gloves and eye protection.
- ⇒ Do not loosen the screw of the optional test connection while the ball valve is pressurised.
- ⇒ Bring the ball valve into the open position so the pressure is released from the ball.

Danger of injury due to preloaded springs!

Actuators with preloaded actuator springs are pressurised.

- ⇒ Before working on the actuator, release the compression from the preloaded springs.

Prior to disassembly, make sure that the following conditions are met:

- The ball valve is decommissioned, see chapter "10 Decommissioning".

11.1 Removing the multy-way ball valve from the pipe

- ⇒ Loosen the flange connection.
- ⇒ Remove the ball valve from the pipe, see Chapter "4.3 Transporting and lifting the ball valve".

WARNING

If a used valve is sent to PFEIFFER for service:

- ⇒ Decontaminate the valves properly in advance.

- ⇒ When returning a used valve, include the safety data sheet for the medium as well as confirmation of decontamination of the valve. Otherwise the valve will not be accepted.

Tip

- PFEIFFER recommends documenting the following contamination data in the form ► FM 8.7-6 "Declaration regarding the contamination of PFEIFFER valves and components".
- This form is available at ► www.pfeiffer-armaturen.com.

11.2 Disassembling the actuator

See the corresponding actuator documentation.

12 Repairs

If the operation of the ball valve is no longer compliant or if it does not work at all, it is defective and must be repaired or replaced.

! NOTE

Damage to the ball valve due to improper maintenance and repair!

- ⇒ Do not perform maintenance and repair work on your own.
- ⇒ Contact the After Sales Service at PFEIFFER for maintenance and repair work.

In special cases, certain maintenance and repair work may be performed.

The work described in this chapter may only be performed by specialist personnel qualified to perform the corresponding task.

The following instructions apply additionally for ball valves. For decommissioning and disassembly, observe Chapter "10 Decommissioning" and Chapter "11 Disassembly".

12.1 Replacing the V-ring packing

If a leak is found in the stuffing box flange (6), the PTFE rings of the V-ring packing (14) could be defective.

- ⇒ Check the condition of the V-ring packing.

Disassemble the ball valve to remove the packing. For this purpose, observe Chapter "1 Safety instructions and safety measures".

- ⇒ Place the ball valve on an even and clean work surface so that the packing space is easy to reach.
- ⇒ Loosen the screws (19) and remove the stuffing box flange (6) carefully.
- ⇒ Depending on the nominal size and version, remove the bushing (24).
- ⇒ Remove the disc springs from the disc spring set (13).
- ⇒ Remove the V-ring packing (14).
- ⇒ Check the PTFE rings of the V-ring packing as well as all plastic and graphite parts for damage and, in the case of doubt, replace them.
- ⇒ Assemble the ball valve as described in chapter "3.5 Assembling the multi-way ball valve". Observe the respective design of the ball valve.

12.2 Replacing the seat ring and the ball

If there is a leak in the passage, the seat ring (4) and the ball (3) can be defective.

- ⇒ Check the condition of the seat ring and the ball.

Disassemble the ball valve to remove the seat ring and ball of the ball valve. For this purpose, observe Chapter "1 Safety instructions and safety measures".

12.2.1 Disassembly of the multi-port ball valve, DN 15 to 32 and NPS $\frac{1}{2}$ to 1 $\frac{1}{4}$

- ⇒ Version of the ball valve, see Fig. 12-1.
- ⇒ Place the ball valve on an even and clean work surface so that all flange mounting sides are easy to reach.
- ⇒ Loosen the screws (15) and carefully remove both body flanges (2).

i Info

Depending on the nominal size, stud bolts (15) with nuts (16) or screws (15) can be used.

- ⇒ Loosen the screws (17) and carefully remove the outlet flange(s) (3).

i Info

Depending on the nominal size, stud bolts (17) with nuts (18) or screws (17) can be used.

- ⇒ Carefully loosen the ball (4) from the control shaft (5) and remove it from the main body (1).
- ⇒ Check the seat rings and the ball as well as all plastic and graphite parts for damage and, in the case of doubt, replace them.
- ⇒ Assemble the ball valve as described in chapter "3.5 Assembling the multi-way ball valve".

12.2.2 Disassembly of the multi-port ball valve, DN 40 to 200 and NPS1 $\frac{1}{2}$ to 8

- ⇒ Version of the ball valve, see Fig. 12-2.
- ⇒ Place the ball valve on an even and clean work surface so that all flange mounting sides are easy to reach.
- ⇒ Loosen the screws (15) and carefully remove the horizontal body flanges (2).

i Info

Depending on the nominal size, stud bolts (15) with nuts (16) or screws (15) can be used.

- ⇒ Loosen the screws (29) and carefully remove the bonnet flange (23) with the control shaft (5).
- ⇒ Carefully loosen the ball (4) and remove it from the main body (1).

i Info

Depending on the version, the ball in the main body (1) can be double mounted with the bearing bush (28).

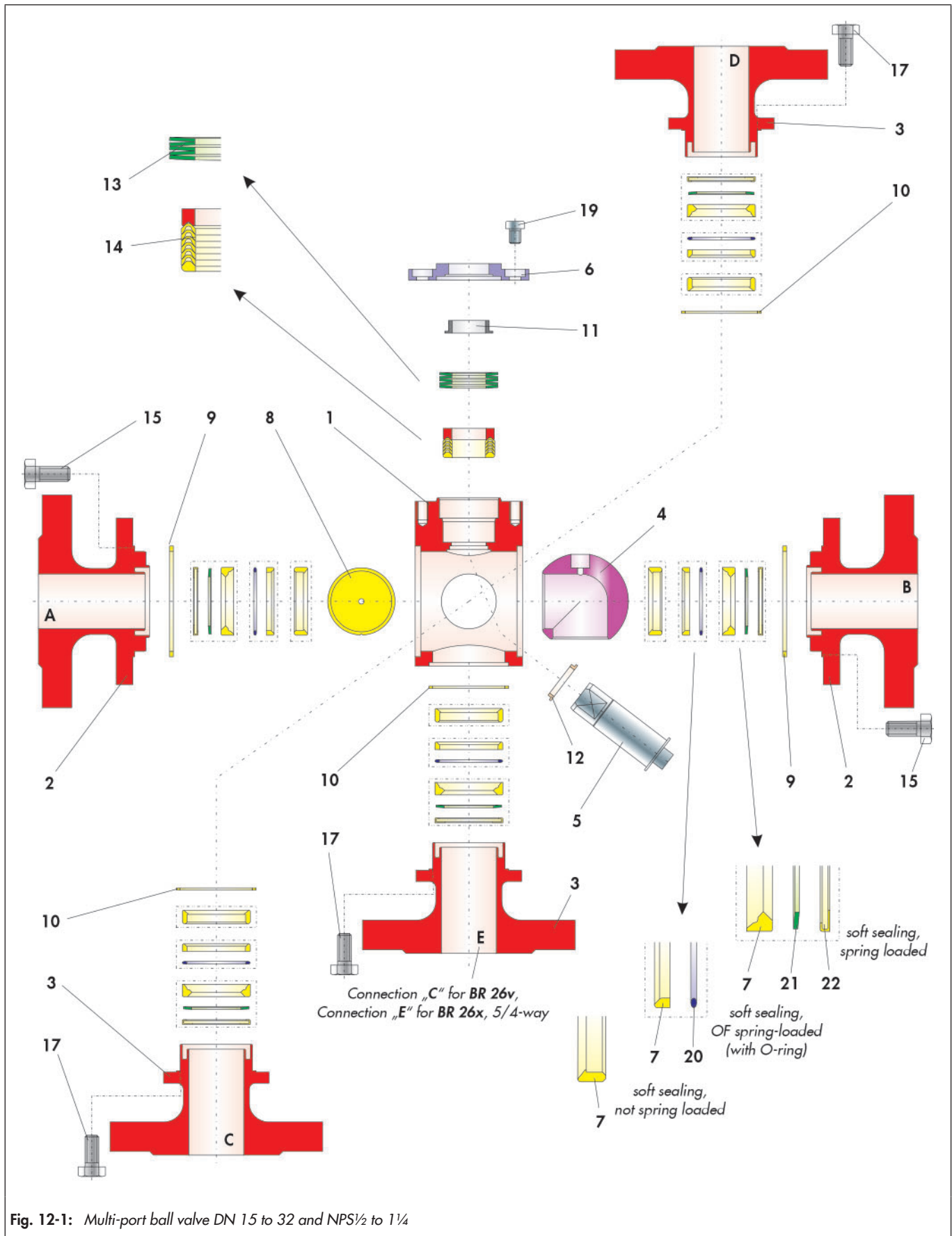

Fig. 12-1: Multi-port ball valve DN 15 to 32 and NPS½ to 1¼

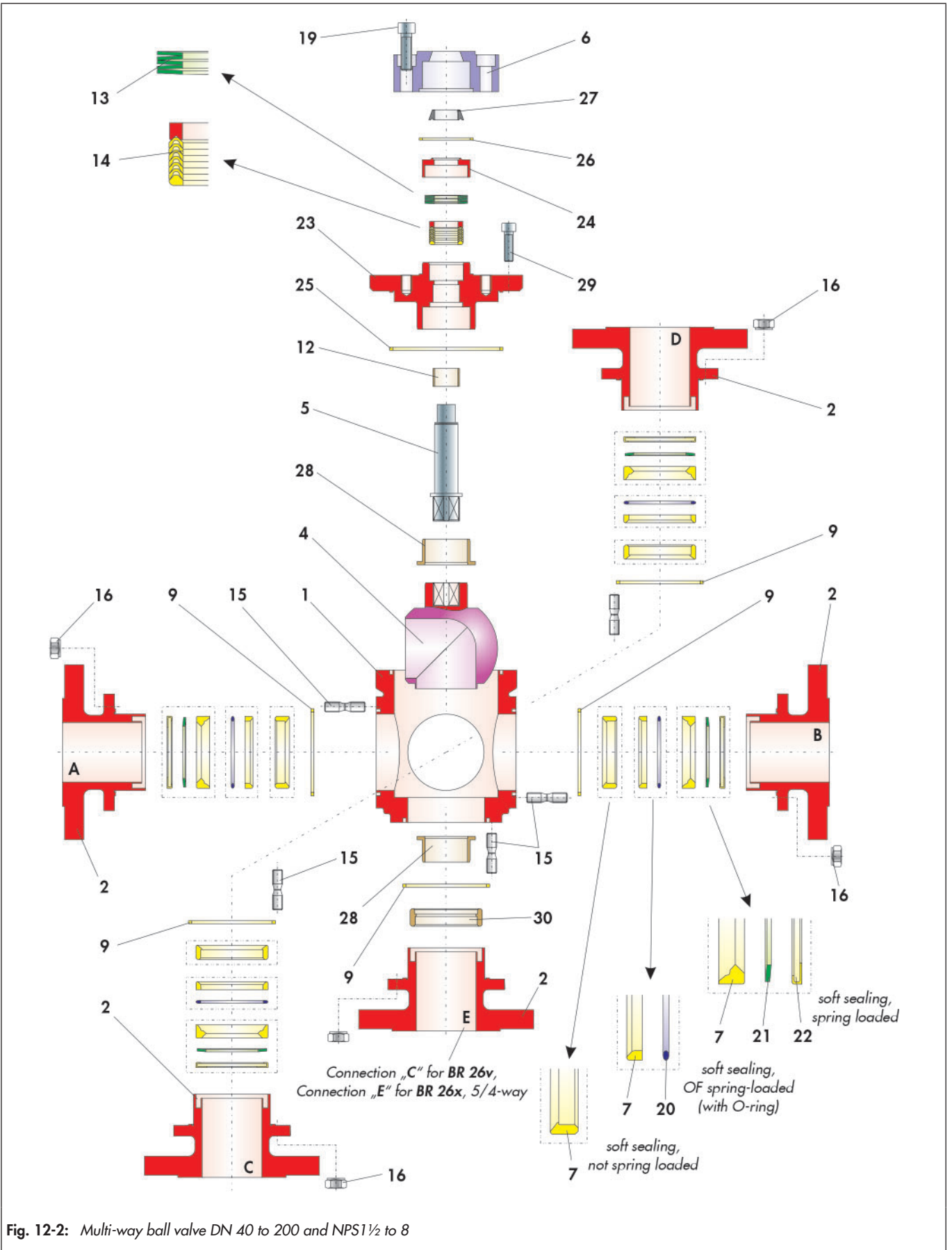

Fig. 12-2: Multi-way ball valve DN 40 to 200 and NPS1½ to 8

Table 12-1: List of parts

Item	Description	Item	Description
1	Main body	16 ¹⁾	Nut
2	Body flange	17 ¹⁾	Stud bolt / Screw
3	Outlet flange	18 ¹⁾	Nut
4	Ball	19	Screw
5	Control shaft	20	O-ring
6	Stuffing box flange	21	Disc spring
7	Seat ring	22	Disc spring jacket
8	Counter bearing	23	Bonnet flange
9	Sealing	24	Bush
10	Sealing	25	Ring
11	Bearing bush	26	Ring
12	Bearing bush	27	Ring
13	Disc spring set	28	Bearing bush
14	V-ring packing	29	Screw
15 ¹⁾	Stud bolt / Screw	30	Bearing ring

¹⁾ Depending on the nominal width, stud bolts can be fitted with nuts or screws.

- ⇒ Check the seat rings and the ball as well as all plastic and graphite parts for damage and, in the case of doubt, replace them.
- ⇒ Assemble the ball valve as described in chapter "3.5 Assembling the multi-way ball valve".

12.3 Additional repairs

- ⇒ In the case of additional major damage, it is recommended to have repairs performed by PFEIFFER.

12.4 Sending devices to PFEIFFER

Defective ball valves can be sent to PFEIFFER for repair.

Proceed as follows to send devices:

WARNING

Danger due to a contaminated ball valve!

- ⇒ When returning a used valve to PFEIFFER for service, decontaminate the valve properly in advance.
- ⇒ When returning a used valve, include the safety data sheet for the medium as well as confirmation of decontamination of the valve. Otherwise the valve will not be accepted.

Tip

- PFEIFFER recommends documenting the following contamination data in the form ► FM 8.7-6 "Declaration regarding the contamination of PFEIFFER valves and components".
- This form is available at ► www.pfeiffer-armaturen.com.

- ⇒ Include the following information for returns:
 - Manufacturer number
 - Ball valve type
 - Article number
 - Nominal size and version of the ball valve
 - Manual valve/automated valve
 - Medium (designation and consistency)
 - Medium pressure and temperature
 - Flow rate in m³/h
 - Bench range of the actuator
 - Number of actuations (year, month, week or day)
 - Installation drawing if available
 - Completed declaration regarding contamination. This form is available at ► www.pfeiffer-armaturen.com.

13 Disposal

- ⇒ For disposal, observe the local, national and international regulations.
- ⇒ Do not dispose of old components, lubricant and hazardous materials with domestic waste.

14 Certificates

The declaration of conformity is available on the following pages:

- Declaration of conformity according to Pressure Equipment Directive 2014/68/EU for automated valves, see page 14-2.
- Declaration of conformity according to Pressure Equipment Directive 2014/68/EU for manually operated valves, see page 14-3.
- Declaration of conformity for completed machinery according to Machinery Directive 2006/42/EC for the ball valve BR 26l, BR 26t, BR 26v and BR 26x, see page 14-4.
- Declaration of conformity for partly completed machinery according to Machinery Directive 2006/42/EC for ball valve BR 26l, BR 26t, BR 26v and BR 26x, see page 14-5.

The printed certificates correspond to the status at the time of printing. Further optional certificates are available upon request.

DECLARATION OF CONFORMITY

As per Pressure Equipment Directive 2014/68/EU
TRANSLATION



The manufacturer	PFEIFFER Chemie-Armaturenbau GmbH , D47906 Kempen, Germany
declares that:	Type 26l, Type 26t, Type 26v and Type 26x Multi-port Ball valves (BR 26l), (BR 26t), (BR 26v), (BR 26x), with stuffing box packing <ul style="list-style-type: none"> • with pneumatic/ electric/ hydraulic actuator • with free shaft end for subsequent mounting of an actuator
<ol style="list-style-type: none"> 1. The valves are pressure accessories within the meaning of the Pressure Equipment Directive 2014/68/EU and conform with the requirements of this Directive. 2. They may only be operated observing the Installation and operating instructions ► BA 26l-01 and/or ► EB 26l delivered together with the valve. <p>The commissioning of these valves is only permitted after the valve has been installed from both sides in the pipeline and a risk of injury can be ruled out. (See ► BA 26l-01, section 2.3 for ball valves intended for dead-end service)</p>	

Applied standards:

AD 2000 Regulations	Regulations for pressurized valve body parts
----------------------------	--

Type designation and technical features:

PFEIFFER Data sheet ► TB 26l NOTE: This Manufacturer's Declaration applies to all valve types listed in this catalogue.
--

Applied conformity assessment procedure:

Conforming to Annex III of the Pressure Equipment Directive 2014/68/EU, Module H

Name of notified body:

Identification number of the notified body:

TÜV Rheinland Service GmbH Am Grauen Stein 51101 Köln Germany	0035
---	------

These Declarations become invalid when modifications are made to the ball valves and/or assemblies that affect the technical data of the ball valve or the <Intended use> described in ► BA 26l-01, section 1 of the operating instructions, and considerably change the valve or an assembly delivered with it.

Kempen, 1. September 2022



Stefan Czayka
 Head of Quality Management/IMS Representative

DECLARATION OF CONFORMITY

As per Pressure Equipment Directive 2014/68/EU
TRANSLATION



The manufacturer	PFEIFFER Chemie-Armaturenbau GmbH , D47906 Kempen, Germany
declares that:	Type 26l, Type 26t, Type 26v and Type 26x Multi-port Ball valves (BR 26l), (BR 26t), (BR 26v), (BR 26x), with stuffing box packing • with lever
<ol style="list-style-type: none"> The valves are pressure accessories within the meaning of the Pressure Equipment Directive 2014/68/EU and conform with the requirements of this Directive. They may only be operated observing the Installation and operating instructions ► BA 26l-02 and/or ► EB 26l delivered together with the valve. <p>(See ► BA 26l-02, section 2.3 for ball valves intended for dead-end service)</p>	

Applied standards:

AD 2000 Regulations	Regulations for pressurized valve body parts
----------------------------	--

Type designation and technical features:

PFEIFFER Data sheet ► TB 26l NOTE: This Manufacturer's Declaration applies to all valve types listed in this catalogue.
--

Applied conformity assessment procedure:

Conforming to Annex III of the Pressure Equipment Directive 2014/68/EU, Module H

Name of notified body:

Identification number of the notified body:

TÜV Rheinland Service GmbH Am Grauen Stein 51101 Köln Germany	0035
---	------

These Declarations become invalid when modifications are made to the ball valves and/or assemblies that affect the technical data of the ball valve or the <Intended use> described in ► BA 26l-02, section 1 of the operating instructions, and considerably change the valve or an assembly delivered with it.

Kempen, 1. September 2022

Stefan Czayka
Head of Quality Management/IMS Representative

EU DECLARATION OF CONFORMITY TRANSLATION



The manufacturer	PFEIFFER Chemie-Armaturenbau GmbH , 47906 Kempen, Germany
declares for the listed products that:	<p>Type 26l (BR26l), Type 26t (BR26t), Type 26v (BR26v), Type 26x (BR26x), Multi-port Ball Valve</p> <ul style="list-style-type: none"> • with a Type 31a Quarter-turn Actuator (BR31a) • with a rotary actuator of a different make <p>Prerequisite: the unit was sized and assembled by PFEIFFER Chemie-Armaturenbau GmbH. The serial number on the valve refers to the entire unit.</p>
<p>1. It complies with all applicable requirements stipulated in Machinery Directive 2006/42/EC.</p> <p>2. In the delivered state, the valve with actuator is considered to be final machinery as defined in the above mentioned directive.</p> <p>The start-up of these units is only permitted after the valve has been installed from all sides in the pipeline and a risk of injury can be ruled out as a result.</p>	

Referenced standards:

a)	VCI, VDMA, VGB: "Leitfaden Maschinenrichtlinie (2006/42/EG) – Bedeutung für Armaturen, Mai 2018" [German only]
b)	VCI, VDMA, VGB: "Zusatzdokument zum Leitfaden Maschinenrichtlinie (2006/42/EG) – Bedeutung für Armaturen vom Mai 2018" [German only], based on DIN EN ISO 12100:2011-03

Product description and technical features:

<p>Tight-closing ball valve for aggressive media, particularly for strict requirements in chemical applications, automated with a single or double-acting piston actuator for butterfly valves, ball valves and other valves with rotating throttle bodies.</p> <p>For product descriptions refer to: PFEIFFER data sheet for Type 26l, Type 26t, Type 26v, Type 26x Valve ▶ TB26l PFEIFFER data sheet for Type 31a Actuator ▶ TB31a PFEIFFER operating instructions for Type 26l, Type 26t, Type 26v, Type 26x Valve ▶ BA26l-01 / ▶ BA26l-02 PFEIFFER maintenance instructions for Type 26l, Type 26t, Type 26v, Type 26x Valve ▶ EB26l PFEIFFER mounting and operating instructions for Type 31a Actuator ▶ EB 31a PFEIFFER safety manual for Type 26l, Type 26t, Type 26v, Type 26x Valve ▶ SH 26l PFEIFFER safety manual for Type 31a Actuator ▶ SH 31a</p> <p>Valve accessories (e.g. positioners, limit switches, solenoid valves, lock-up valves, supply pressure regulators, volume boosters and quick exhaust valves) are classified as machinery components and do not fall within the scope of the Machinery Directive as specified in § 35 and § 46 of the Guide to Application of the Machinery Directive 2006/42/EC issued by the European Commission.</p>

This declaration becomes invalid when modifications are made to the ball valves and/or assemblies that affect the technical data of the multi-port ball valve or the intended use ▶ BA26l-01 / ▶ BA26l-02, section 1 and considerably change the valve or an assembly delivered with it.

Persons authorized to compile the technical file:

Kempen, 25 October 2022



Stefan Czayka
 Head of Quality Management/IMS Representative

EU DECLARATION OF CONFORMITY

TRANSLATION



The manufacturer	PFEIFFER Chemie-Armaturenbau GmbH , 47906 Kempen, Germany
declares for the listed products that:	Type 26l (BR26l), Type 26t (BR26t), Type 26v (BR26v), Type 26x (BR26x), Multi-port Ball Valve <ul style="list-style-type: none"> • with free shaft end
<p>1. In the delivered state, the valve prepared for mounting on a rotary actuator (not a clearly defined actuator system) is considered to be partly completed machinery as defined in the Machinery Directive 2006/42/EC.</p> <p>Machinery is considered to be partly completed machinery when the machinery manufacturer has not determined all required specifications such as model type, thrusts, torques etc.</p> <p>The start-up of these units is only permitted after the valve has been installed from all sides in the pipeline and a risk of injury can be ruled out as a result.</p>	

Referenced standards:

- a) VCI, VDMA, VGB: "Leitfaden Maschinenrichtlinie (2006/42/EG) – Bedeutung für Armaturen, Mai 2018" [German only]
- b) VCI, VDMA, VGB: "Zusatzdokument zum Leitfaden Maschinenrichtlinie (2006/42/EG) – Bedeutung für Armaturen vom Mai 2018" [German only], based on DIN EN ISO 12100:2011-03

Product description and technical features:

Tight-closing ball valve for aggressive media, particularly for strict requirements in chemical applications, automated with a single or double-acting piston actuator for butterfly valves, ball valves and other valves with rotating throttle bodies.

For product descriptions refer to

PFEIFFER data sheet for Type 26l, Type 26t, Type 26v, Type 26x Valve ▶ TB26l

PFEIFFER operating instructions for Type 26l, Type 26t, Type 26v, Type 26x Valve ▶ BA26l-01 / ▶ BA26l-02

PFEIFFER maintenance instructions for Type 26l, Type 26t, Type 26v, Type 26x Valve ▶ EB26l

Valve accessories (e.g. positioners, limit switches, solenoid valves, lock-up valves, supply pressure regulators, volume boosters and quick exhaust valves) are classified as machinery components and do not fall within the scope of the Machinery Directive as specified in § 35 and § 46 of the Guide to Application of the Machinery Directive 2006/42/EC issued by the European Commission.

This declaration becomes invalid when modifications are made to the ball valves and/or assemblies that affect the technical data of the multi-port ball valve or the intended use ▶ BA26l-01 / ▶ BA26l-02, section 1 and considerably change the valve or an assembly delivered with it.

Persons authorized to compile the technical file:

Kempen, 25 October 2022

Stefan Czayka

Head of Quality Management/IMS Representative

15 Annex

15.1 Tightening torques, lubricant and tools

15.1.1 Tightening torques

i Info

¹⁾ The tightening torques stated in the tables can only be understood as very rough and non-binding guide values and refer to a coefficient of friction of 0.2 μ . Lubricating the threads leads to indeterminate tightening conditions.

15.1.1.1 Body flanges

For the connection of the body flanges, the screw connections are tightened in a criss-cross pattern with the tightening torques indicated below.

Table 15-1: Body flanges tightening torques

DIN		ANSI		Qty.	Thread (15)	Tightening torque ¹⁾
DN	PN	NPS	class			
15	40	-	-	8	M8	21.5 Nm
	63			On request		
-	-	1/2	150	8	M8	21.5 Nm
			300	8	M8	21.5 Nm
25	40	-	-	8	M10	44 Nm
	63			8	M12	74 Nm
-	-	1	150	8	M10	44 Nm
			300	8	M10	44 Nm
32	40	-	-	On request		
	63					
-	-	1 1/4	150	On request		
			300			
40	40	-	-	16	M8	21.5 Nm
	63			12	M12	74 Nm
-	-	1 1/2	150	16	M8	21.5 Nm
			300	On request		
50	16	-	-	On request		
	40			16	M10	44 Nm
-	-	2	150	16	M10	44 Nm
			300	16	M10	44 Nm
80	16	-	-	16	M12	74 Nm
	63			32	M12	74 Nm
-	-	3	150	16	M12	74 Nm
			300	16	M12	74 Nm
100	16	-	-	16	M12	74 Nm
	40			16	M12	74 Nm
-	-	4	150	16	M12	74 Nm
			300	16	M12	74 Nm
150	16	-	-	16	M16	183 Nm
	40			16	M16	183 Nm

DIN		ANSI		Qty.	Thread (15)	Tightening torque ¹⁾
DN	PN	NPS	class			
-	-	6	150	16	M16	183 Nm
			300	16	M16	183 Nm
200	10	-	-	24	M16	183 Nm
	40			24	M16	183 Nm
-	-	8	150	On request		
			300			

15.1.1.2 Outlet flanges

For the assembly of the outlet flanges, the screw connections are tightened in a criss-cross pattern with the tightening torques indicated below.

Table 15-2: Outlet flanges tightening torques

DIN		ANSI		Qty.	Thread (17)	Tightening torque ¹⁾
DN	PN	NPS	class			
15	40	-	-	4	M8	21.5 Nm
	63			On request		
-	-	1/2	150	4	M8	21.5 Nm
			300	4	M8	21.5 Nm
25	40	-	-	4	M8	21.5 Nm
	63			4	M12	74 Nm
-	-	1	150	4	M8	21.5 Nm
			300	4	M8	21.5 Nm
32	40	-	-	On request		
	63					
-	-	1 1/4	150	8	M8	21.5 Nm
			300	On request		

15.1.1.3 Stuffing box flange

For the assembly of the stuffing box flange, the screw connections are tightened in a criss-cross pattern with the tightening torques indicated below.

Table 15-3: Stuffing box flange tightening torques

DIN		ANSI		Qty.	Thread (19)	Tightening torque ^{1) 2)}
DN	PN	NPS	class			
15	40	-	-	4	M6	8.8 Nm
	63			On request		
-	-	1/2	150	4	M6	8.8 Nm
			300	4	M6	8.8 Nm
25	40	-	-	4	M6	8.8 Nm
	63			6	M12	74 Nm
-	-	1	150	4	M6	8.8 Nm
			300	4	M6	8.8 Nm
32	40	-	-	On request		
	63					
-	-	1 1/4	150	On request		
			300			

DIN		ANSI		Qty.	Thread (19)	Tightening torque ^{1) 2)}
DN	PN	NPS	class			
40	40	-	-	4	M10	44 Nm
	63			12	M12	74 Nm
-	-	1½	150	4	M10	44 Nm
			300	On request		
50	16	-	-	On request		
	40			4	M10	44 Nm
-	-	2	150	4	M10	44 Nm
			300	4	M10	44 Nm
80	40	-	-	4	M12	74 Nm
	63			16	M12	74 Nm
-	-	3	150	4	M12	74 Nm
			300	4	M12	74 Nm
100	16	-	-	4	M12	74 Nm
	40			4	M12	74 Nm
-	-	4	150	4	M12	74 Nm
			300	4	M12	74 Nm
150	16	-	-	4	M20	370 Nm
	40			4	M20	370 Nm
-	-	6	150	4	M20	370 Nm
			300	4	M20	370 Nm
200	10	-	-	4	M20	370 Nm
	40			4	M20	370 Nm
-	-	8	150	On request		
			300	On request		

²⁾ Tighten the stuffing box screws until the bushing lies on the dome.

15.1.1.4 Bonnet flange

For the assembly of the bonnet flange, the screw connections are tightened in a criss-cross pattern with the tightening torques indicated below.

Table 15-4: Bonnet flange tightening torques

DIN		ANSI		Qty.	Thread (29)	Tightening torque ¹⁾
DN	PN	NPS	class			
40	40	-	-	10	M10	44 Nm
	63			On request		
-	-	1½	150	10	M10	44 Nm
			300	On request		
50	16	-	-	On request		
	40			10	M10	44 Nm
-	-	2	150	10	M10	44 Nm
			300	10	M10	44 Nm
80	40	-	-	18	M12	74 Nm
	63			14	M16	183 Nm
-	-	3	150	18	M12	74 Nm
			300	18	M12	74 Nm
100	16	-	-	16	M12	74 Nm
	40			16	M12	74 Nm

DIN		ANSI		Qty.	Thread (29)	Tightening torque ¹⁾
DN	PN	NPS	class			
-	-	4	150	16	M12	74 Nm
			300	16	M12	74 Nm
150	16	-	-	16	M16	183 Nm
	40			16	M16	183 Nm
-	-	6	150	16	M16	183 Nm
			300	16	M16	183 Nm
200	10	-	-	On request		
	40			On request		
-	-	8	150	20	M16	183 Nm
			300	20	M16	183 Nm

15.1.1.5 Flange connection

i Info

Required tightening torques for assembly for flanges according to DIN EN 1092-1 type 11 and connecting elements (e.g. screws, threaded pins) made of 25CrMo4 / A4-70 or a comparable strength.

The values are taken from the "Guidelines for assembly of flange connections in processing plants" of the VCI (Verband der Chemischen Industrie e.V.).

Table 15-5: Flange connection torque

DN	PN	Thread	Tightening torques [Nm] for sealing units ³⁾		Tightening method ⁴⁾
			A	B	
15	10 ... 40	M12	50	50	I
25					
32		M16	125 ⁴⁾	80	
40					
50	M16	125 ⁴⁾	80		
80					
100	10 ... 16	M16	240 ⁵⁾	150	I
	25 ... 40	M20			
125	10 ... 16	M16	125 ⁴⁾	80	II
	25 ... 40	M24	340	200	
150	10 ... 16	M20	240 ⁵⁾	150	I
	25 ... 40	M24	340	200	II
200	10 ... 16	M20	240 ⁵⁾	150	I
	25	M24	340	200	II
	40	M27	500	250	

³⁾ These tightening torques were calculated by the company BASF SE and confirmed by partner companies.

⁴⁾ Recommended lever length 300 mm.

⁵⁾ Recommended lever length 550 mm.

⁶⁾ I) With manually-operated spanner with a suitable extension if necessary.

II) With a torque wrench or other torque-controlled procedure.

Table 15-6: Sealing unit A

Seal	Nominal pressure	Description
Flat seal	PN 10 to PN 25	Without inner eyelet
	PN 40	With inner eyelet

Shaft ring seals PN 40 are covered by this.
Flat seals with inner eyelet for PN 10 - 25 are already covered, providing that the required characteristic values are complied with.

Table 15-7: Sealing unit B

Seal	Nominal pressure	Description
Seal for tongue and groove flanges	PN 10 to PN 40	With fibre gaskets and metal-reinforced graphite gaskets
Grooved gasket		-
Spiral gasket with graphite		-

15.1.2 Lubricant

Table 15-8: Recommended lubricant

Use	Temperature range	Lubricant
Screws and nuts	-10 ... +200 °C	Heavy-duty grease paste (e.g. Gleitmo 805, manufacturer Fuchs) Not suitable for grease-free ball valves or for use with oxygen

15.1.3 Tools

Suitable tools are required to work on the ball valve. Unsuitable tools can damage the ball valve.

15.2 Spare parts

PFEIFFER recommends spare part sets for "Commissioning" and for "2-year operation", see Chapter:

- "15.2.1 Spare parts of the multi-way ball valve **DN 15 bis 32** and **NPS1/2 bis 1 1/4**" on **page 15-8** and
- "15.2.2 Spare parts of the multi-way ball valve **DN 40 bis 200** und **NPS1 1/2 bis 8**" on **page 15-8**.

15.2.1 Spare parts of the multi-way ball valve DN 15 bis 32 and NPS $\frac{1}{2}$ bis 1 $\frac{1}{4}$

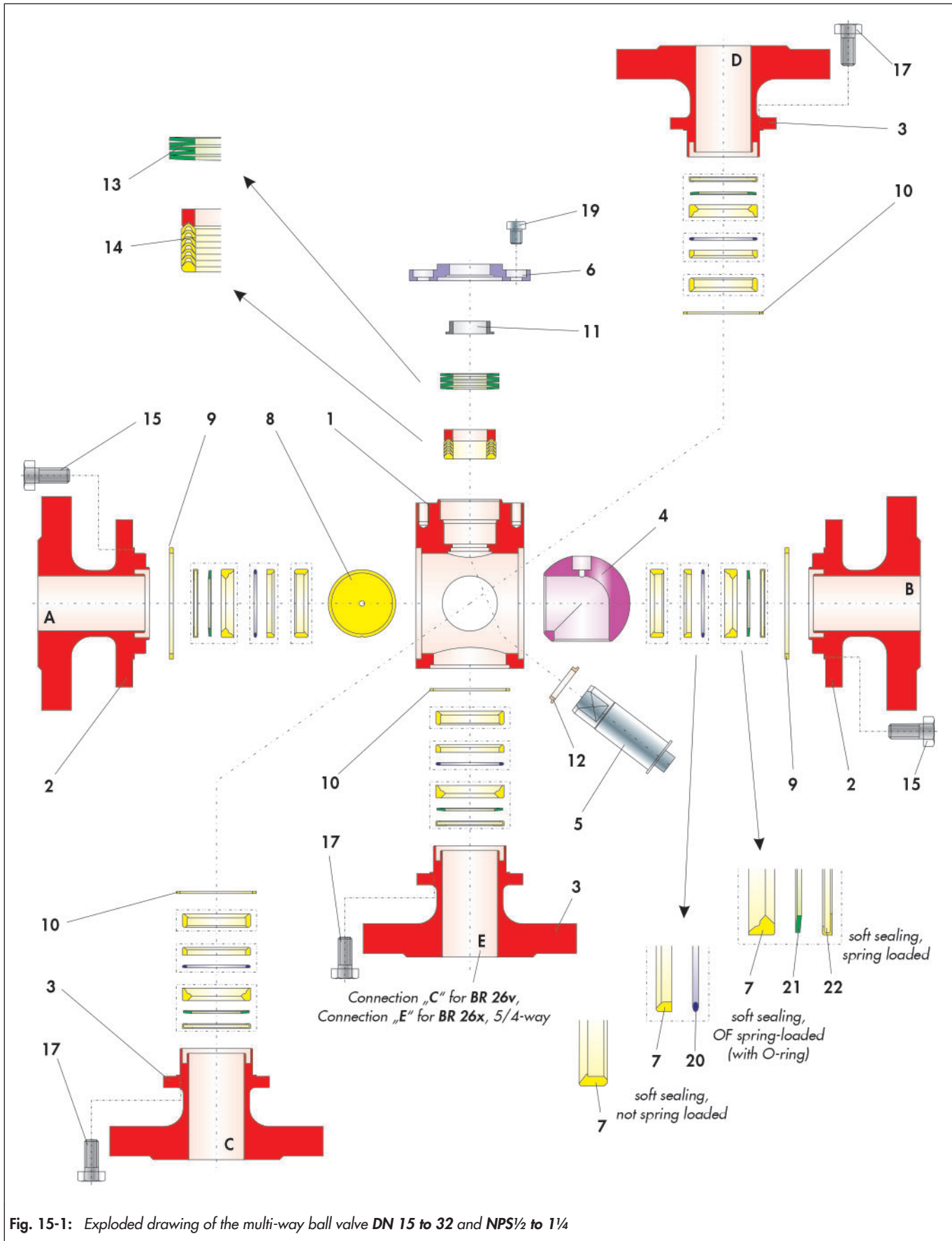

Fig. 15-1: Exploded drawing of the multi-way ball valve DN 15 to 32 and NPS $\frac{1}{2}$ to 1 $\frac{1}{4}$

Table 15-9: Part list of the multi-way ball valve DN 15 to 32 and NPS½ to 1¼

Item	Description	Qty.					Material	Spare part kit	
		BR 26l Horizontal 3-way	BR 26t Horizontal 3-way	BR 26v Vertical 3-way	BR 26x Horizontal 4-way	BR 26x 5/4-way		Commis- sioning	2-year operation
1	Main body	1					1.4571 • 1.4408		
2	Body flange	2	2	2	2	2	1.4571 • 1.4408		
3	Outlet flange	1	1	1	2	3	1.4571 • 1.4408		
4	Ball	1					1.4571 • 1.4408		•
5	Control flange	1					1.4462		•
6	Stuffing box flange	1					1.4571 • 1.4408		
7	Seat ring	3	3	3	4	5	PTFE	•	•
8	Counter bearing	1	1	-	-	-	PTFE	•	•
9	Sealing	2	2	2	2	2	PTFE	•	•
10	Sealing	1	1	1	2	3	PTFE	•	•
11	Bearing bush	1					PTFE with carbon	•	•
12	Bearing bush	1					PTFE with glass	•	•
13	Disc spring set	1					1.8159 Deltatone	•	•
14	V-ring packing	1					PTFE / 1.4305	•	•
15 ¹⁾	Stud bolt / Screw	variabel					A4-70		
16 ¹⁾	Nut	variabel					A4-70		
17 ¹⁾	Stud bolt / Screw	variabel					A4-70		
18 ¹⁾	Nut	variabel					A4-70		
19	Screw	variabel					A4-70		
20	O-ring (Option)	3	3	3	4	5	Viton	•	•
21	Disc spring (Option)	3	3	3	4	5	1.4404	•	•
22	Disc spring jacket (Option)	3	3	3	4	5	PTFE	•	•

¹⁾ Depending on the nominal width, stud bolts can be fitted with nuts or screws.

Table 15-10: Part list of the multi-way ball valve DN 40 to 200 and NPS1½ to 8

Item	Description	Qty.					Material	Spare part kit	
		BR 26l Horizontal 3-way	BR 26t Horizontal 3-way	BR 26v Vertical 3-way	BR 26x Horizontal 4-way	5/4-way		Commis- sioning	2-year operation
1	Main body	1					1.4571 • 1.4408		
2	Body flange	3	3	3	4	5	1.4571 • 1.4408		
4	Ball	1					1.4571 • 1.4408		•
5	Control shaft	1					1.4462		•
6	Stuffing box flange	1					1.4571 • 1.4408		
7	Seat ring	3	3	3	4	5	PTFE	•	•
9	Sealing	3	3	3	4	5	PTFE	•	•
12	Bearing bush	1					PTFE with glass	•	•
13	Disc spring set	1					1.8159 Deltatone	•	•
14	V-ring packing	1					PTFE / 1.4305	•	•
15 ¹⁾	Stud bolt / Screw	variabel					A4-70		
16 ¹⁾	Nut	variabel					A4-70		
19	Screw	variabel					A4-70		
20	O-ring (Option)	3	3	3	4	5	Viton	•	•
21	Disc spring (Option)	3	3	3	4	5	1.4404	•	•
22	Disc spring jacket (Option)	3	3	3	4	5	PTFE	•	•
23	Bonnet flange	1					1.4571 • 1.4408		
24	Bush	1					1.4571		
25	Ring	1					PTFE	•	•
26	Ring	1					PTFE	•	•
27	Ring	1					Carbon-Graphite	•	•
28	Bearing bush	2	2	1	2	1	PTFE with VA	•	•
29	Screw						A4-70		
30	Bearing ring	-	-	1	-	1	PTFE with VA	•	•

¹⁾ Depending on the nominal width, stud bolts can be fitted with nuts or screws.

15.3 Service

For maintenance and repair work as well as malfunctions or defects, contact the After Sales Service at PFEIFFER for support.

E-mail

The After Sales Service can be reached at the e-mail address "sales-pfeiffer-de@samsongroup.com".

Necessary data

Provide the following information in the case of questions and for troubleshooting:

- Manufacturer number
- Ball valve type
- Article number
- Nominal size and version of the ball valve
- Manual valve/automated valve
- Medium (designation and consistency)
- Medium pressure and temperature
- Flow rate in m³/h
- Actuator signal pressure
- Number of actuations (year, month, week or day)
- Installation drawing if available
- Completed declaration regarding contamination. This form is available at ► www.pfeiffer-armaturen.com.

Further information

The indicated data sheets and further information are available, also in English, at the following address:

PFEIFFER Chemie-Armaturenbau GmbH

Hooghe Weg 41 • 47906 Kempen • Germany

Phone: +49 2152 2005 0 • Fax +49 2152 1580

E-Mail: sales-pfeiffer-de@samsongroup.com

Internet: www.pfeiffer-armaturen.com



PFEIFFER Chemie-Armaturenbau GmbH

Hooghe Weg 41 · 47906 Kempen · Germany

Phone: +49 2152 2005-0 · Fax: +49 2152 1580

E-Mail: sales-pfeiffer-de@samsongroup.com · Internet: www.pfeiffer-armaturen.com